

# Board of County Commissioners

## Escambia County, Florida

### Commissioners

Wilson Robertson, District - 1 Chair Gene Valentino, District - 2 Vice Chair  
 Grover Robinson, District - 4 Marie Young, District - 3 Kevin White, District - 5

COMPONENTS OF CONTRACT PLANS SET  
 ROADWAY PLANS

#### INDEX OF ROADWAY PLANS

| SHEET NO. | SHEET DESCRIPTION     |
|-----------|-----------------------|
|           | KEY SHEET             |
|           | DRAINAGE MAP          |
|           | TYPICAL SECTIONS      |
|           | ROADWAY PLAN-PROFILES |
|           | POND DETAILS          |
|           | CROSS SECTIONS        |



Plans Proposed for:  
**Kingsfield Road Extension**  
 Escambia County (48030)

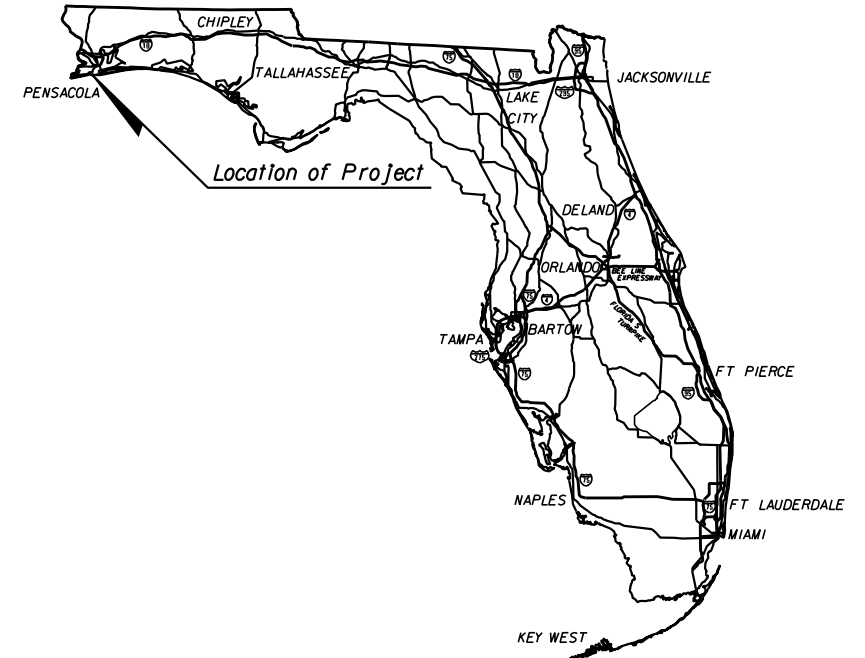

PROJECT LENGTH IS BASED ON @ OF SURVEY

| LENGTH OF PROJECT       |             |       |
|-------------------------|-------------|-------|
|                         | LINEAR FEET | MILES |
| ROADWAY                 | 14,763.71   | 2.796 |
| BRIDGES                 | 100         | 0.019 |
| NET LENGTH OF PROJECT   | 14,863.71   | 2.815 |
| EXCEPTIONS              | 0           | 0     |
| GROSS LENGTH OF PROJECT | 14,863.71   | 2.815 |

| KEY SHEET REVISIONS |             |
|---------------------|-------------|
| DATE                | DESCRIPTION |
|                     |             |
|                     |             |

GOVERNING STANDARDS AND SPECIFICATIONS:  
 FLORIDA DEPARTMENT OF TRANSPORTATION,  
 DESIGN STANDARDS DATED 2012,  
 AND STANDARD SPECIFICATIONS FOR ROAD AND  
 BRIDGE CONSTRUCTION DATED 2010,  
 AS AMENDED BY CONTRACT DOCUMENTS.

APPLICABLE DESIGN STANDARDS MODIFICATIONS:  
 For Design Standards Modifications click on  
 "Design Standards" at the following web site:  
<http://www.dot.state.fl.us/rddesign/>

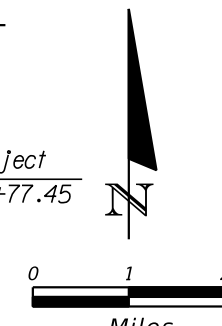
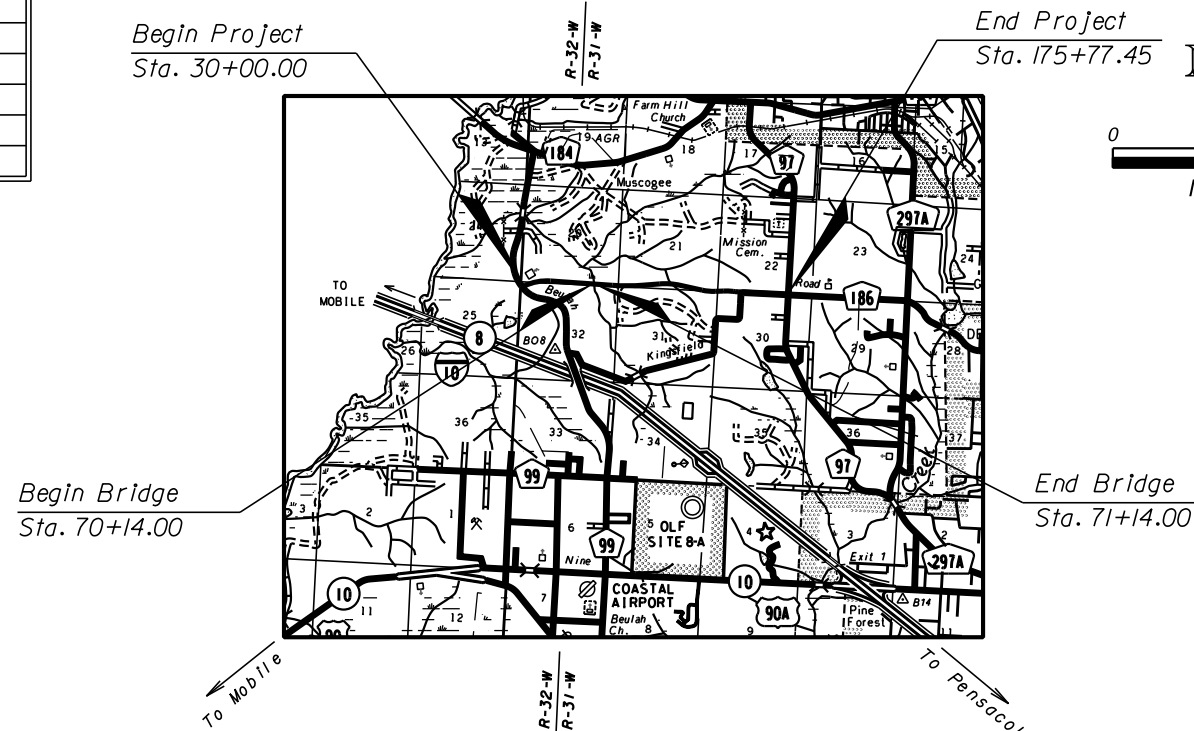

ROADWAY SHOP DRAWINGS  
 TO BE SUBMITTED TO:  
 Hatch Mott MacDonald  
 Attn: David D. Skipper, P.E.  
 Post Office Box 2518  
 Pensacola, Florida 32513  
 (850) 484-6011 - Certificate  
 of Authorization No. 00000155  
 PLANS PREPARED BY:



NOTE: THE SCALE OF THESE PLANS MAY  
 HAVE CHANGED DUE TO REPRODUCTION.

**PHASE I SUBMITTAL**  
 June 2012

ROADWAY PLANS  
 ENGINEER OF RECORD: David D. Skipper, P.E.  
 P.E. NO. 58972

Kingsfield Road Extension

| FISCAL YEAR | SHEET NO. |
|-------------|-----------|
|             | 1         |

NOTICE: THE OFFICIAL RECORD OF THIS SHEET IS THE ELECTRONIC FILE SIGNED AND SEALED UNDER RULE 61G15-23.003, F.A.C.

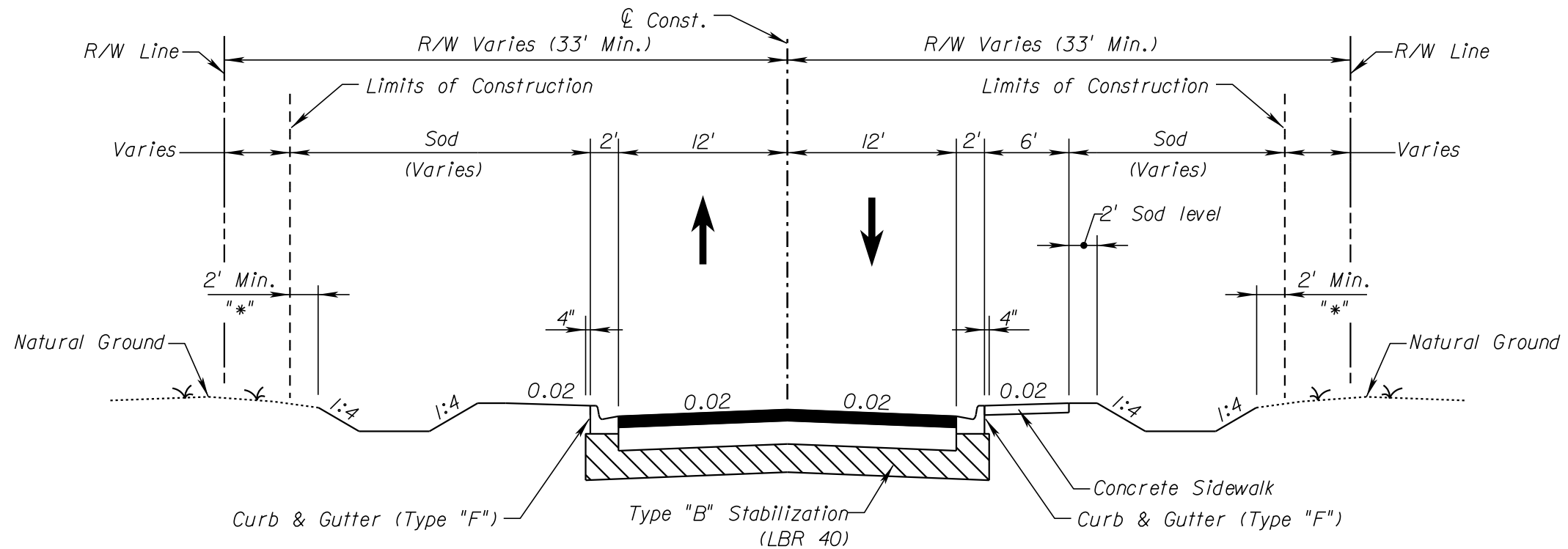

Urban Typical Section No. 2

NOTICE: THE OFFICIAL RECORD OF THIS SHEET IS THE ELECTRONIC FILE SIGNED AND SEALED UNDER RULE 61G15-23.003, F.A.C.

| REVISIONS |             |      |             |
|-----------|-------------|------|-------------|
| DATE      | DESCRIPTION | DATE | DESCRIPTION |
|           |             |      |             |

**Hatch Mott MacDonald**  
 Post Office Box 2518 5111 North 12th Avenue  
 Pensacola, Florida 32513 (850) 484-6011  
 Engineer of Record: David D. Skipper, P.E. \*58972





|  |          |                      |
|--|----------|----------------------|
| <b>Board of County Commissioners</b><br>Escambia County, Florida |          |                      |
| ROAD NO.   | COUNTY   | FINANCIAL PROJECT ID |
|  | ESCAMBIA |                      |

**TYPICAL SECTIONS**

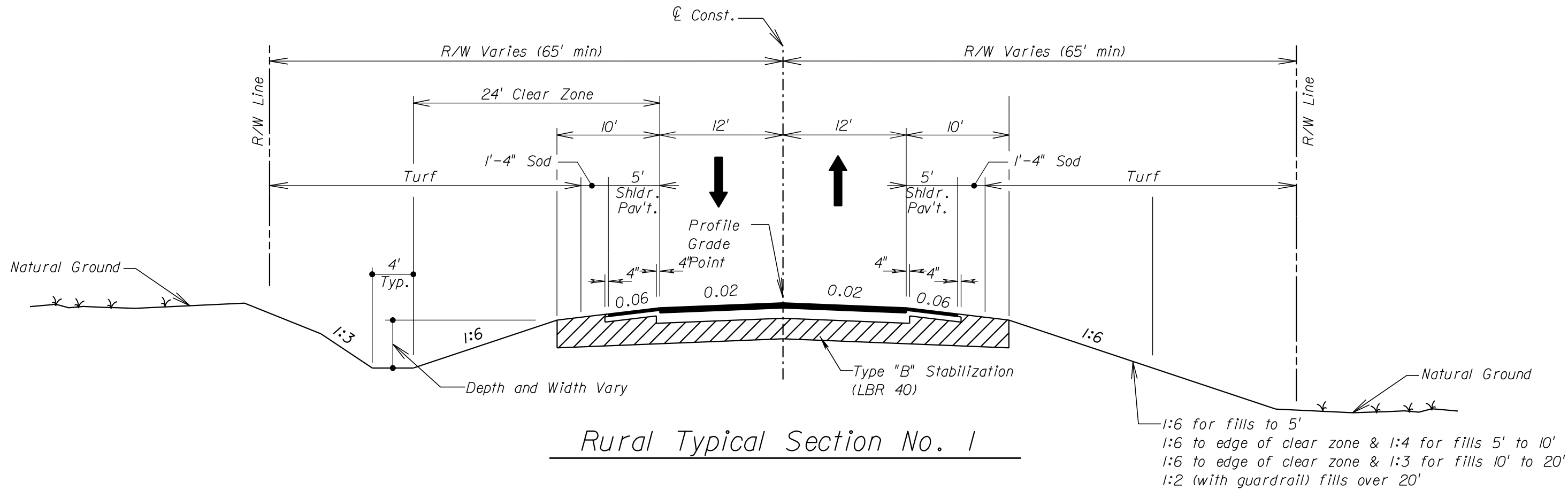
|           |
|-----------|
| SHEET NO. |
|           |



NOTICE: THE OFFICIAL RECORD OF THIS SHEET IS THE ELECTRONIC FILE SIGNED AND SEALED UNDER RULE 61G15-23.003, F.A.C.

| REVISIONS |             |                      |             |  <b>Hatch Mott MacDonald</b><br><small>Post Office Box 2518 5111 North 12th Avenue<br/>Pensacola, Florida 32513 (850) 484-6011<br/>Engineer of Record: David D. Skipper, P.E. *58972</small> |  <b>Board of County Commissioners</b><br><small>Escambia County, Florida</small> | <table border="1" style="width: 100%; border-collapse: collapse;"> <tr> <th style="width: 20%;">ROAD NO.</th> <th style="width: 40%;">COUNTY</th> <th style="width: 40%;">FINANCIAL PROJECT ID</th> </tr> <tr> <td> </td> <td style="text-align: center;">ESCAMBIA</td> <td> </td> </tr> </table> |  | ROAD NO. | COUNTY | FINANCIAL PROJECT ID |  | ESCAMBIA |  | SHEET NO. |
|-----------|-------------|----------------------|-------------|---|---|---|--|----------|--------|----------------------|--|----------|--|-----------|
| ROAD NO.  | COUNTY      | FINANCIAL PROJECT ID |             |   |   |   |  |          |        |                      |  |          |  |           |
|           | ESCAMBIA    |                      |             |   |   |   |  |          |        |                      |  |          |  |           |
| DATE      | DESCRIPTION | DATE                 | DESCRIPTION | <b>TYPICAL SECTIONS</b>   |   |   |  |          |        |                      |  |          |  |           |
|           |             |                      |             | <small>7/24/2012 3:47:05 PM p:\296696\drawings\Roadway\TYPDRD01.DGN</small>   |   |   |  |          |        |                      |  |          |  |           |

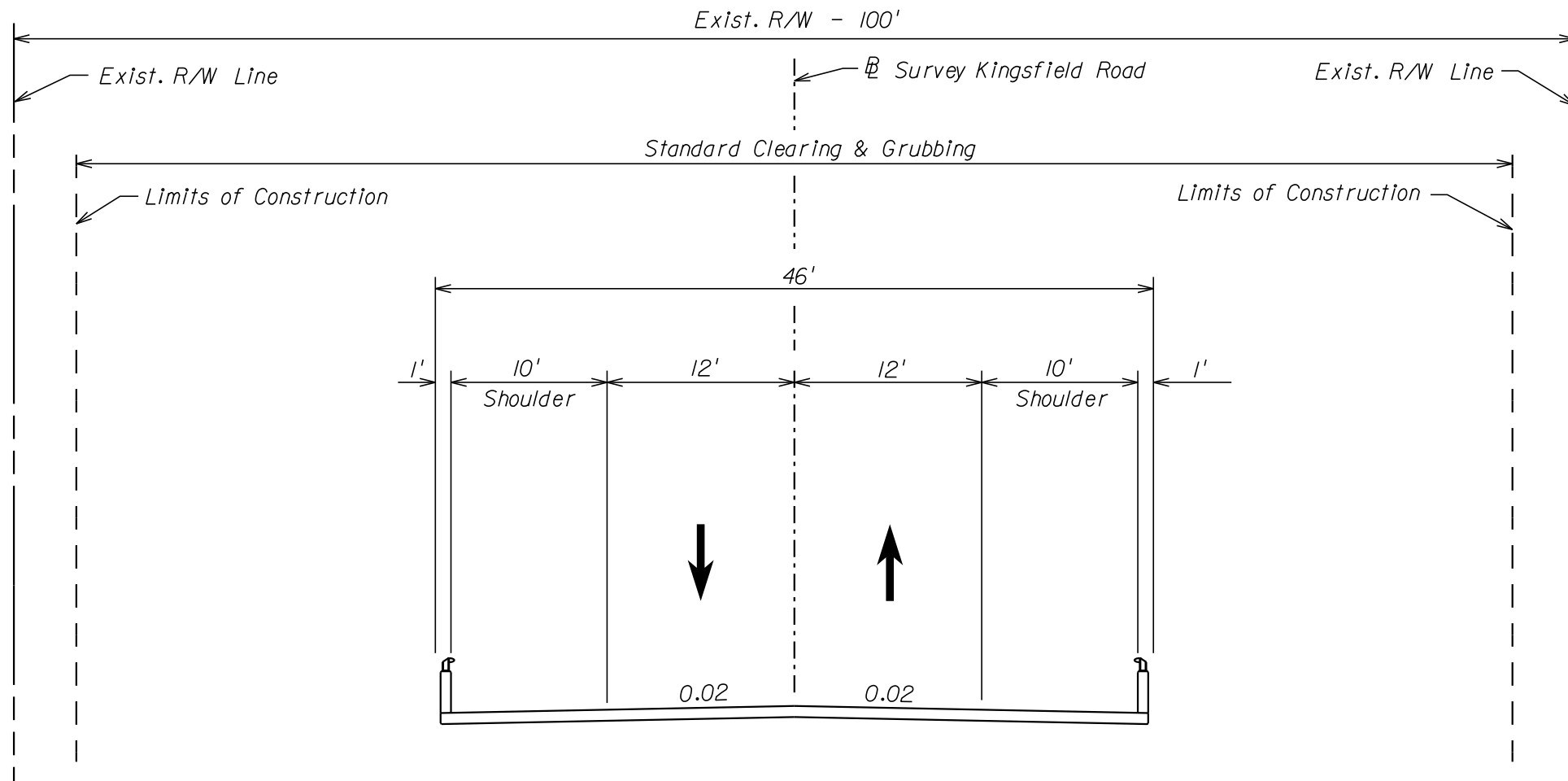

Typical Bridge Section

| REVISIONS |             |      |             |
|-----------|-------------|------|-------------|
| DATE      | DESCRIPTION | DATE | DESCRIPTION |
|           |             |      |             |

**Hatch Mott MacDonald**  
 Post Office Box 2518 5111 North 12th Avenue  
 Pensacola, Florida 32513 (850) 484-6011  
 Engineer of Record: David D. Skipper, P.E. \*58972



|  |          |                      |
|--|----------|----------------------|
| <b>Board of County Commissioners</b><br>Escambia County, Florida |          |                      |
| ROAD NO.   | COUNTY   | FINANCIAL PROJECT ID |
|  | ESCAMBIA |                      |

**TYPICAL SECTIONS**

SHEET NO.

NOTICE: THE OFFICIAL RECORD OF THIS SHEET IS THE ELECTRONIC FILE SIGNED AND SEALED UNDER RULE 61G15-23.003, F.A.C.

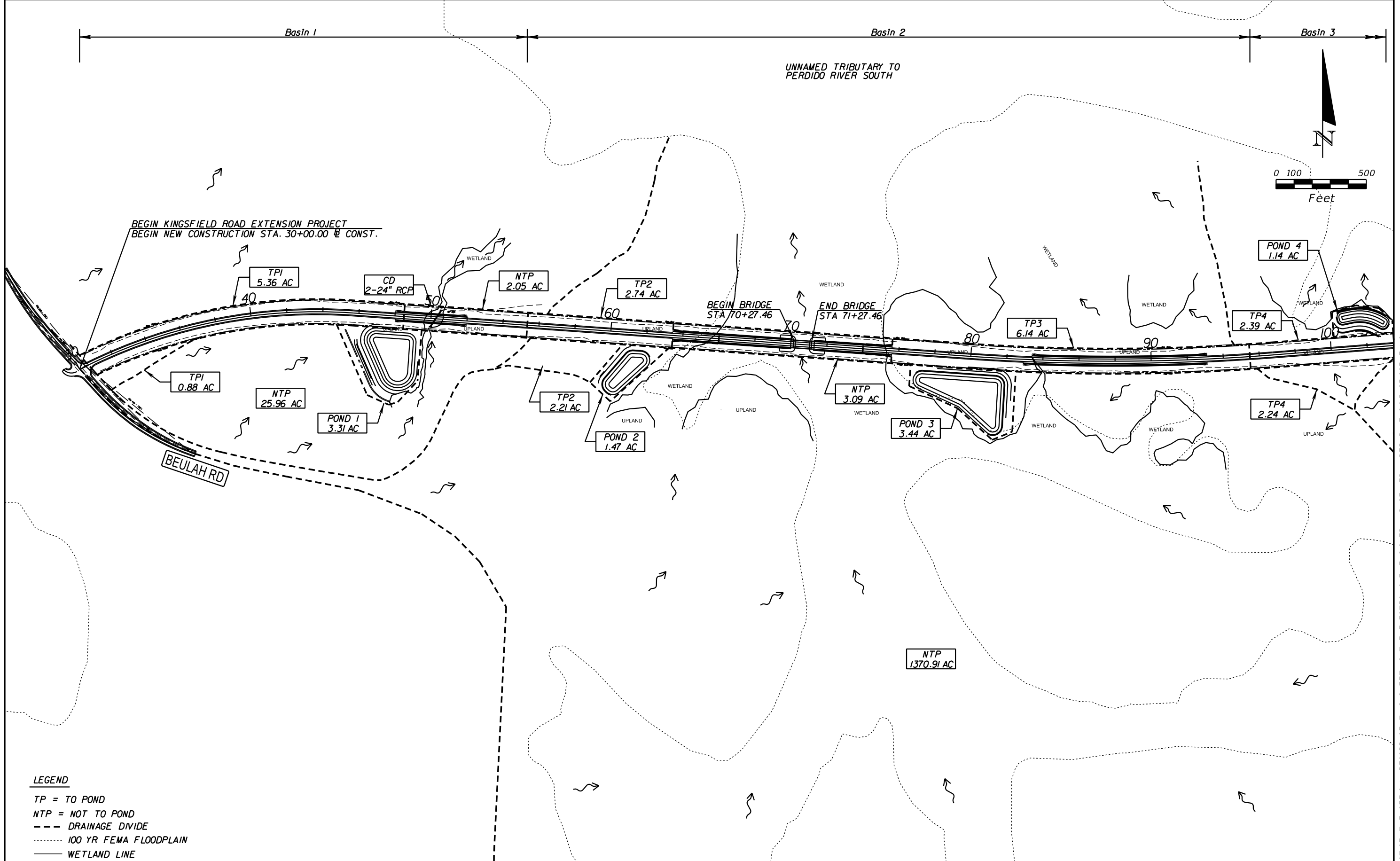

**LEGEND**  
 TP = TO POND  
 NTP = NOT TO POND  
 --- DRAINAGE DIVIDE  
 ..... 100 YR FEMA FLOODPLAIN  
 — WETLAND LINE

| REVISIONS |             |      |             |
|-----------|-------------|------|-------------|
| DATE      | DESCRIPTION | DATE | DESCRIPTION |
|           |             |      |             |

**Hatch Mott MacDonald**  
 Post Office Box 2518 5111 North 12th Avenue  
 Pensacola, Florida 32513 (850) 484-6011  
 Engineer of Records: David D. Skipper, P.E. #58972



**Board of County Commissioners**  
 Escambia County, Florida

|          |          |                      |
|----------|----------|----------------------|
| ROAD NO. | COUNTY   | FINANCIAL PROJECT ID |
|          | ESCAMBIA |                      |

**DRAINAGE MAP OVERVIEW**

SHEET NO.

NOTICE: THE OFFICIAL RECORD OF THIS SHEET IS THE ELECTRONIC FILE SIGNED AND SEALED UNDER RULE 61G15-23.003, F.A.C.

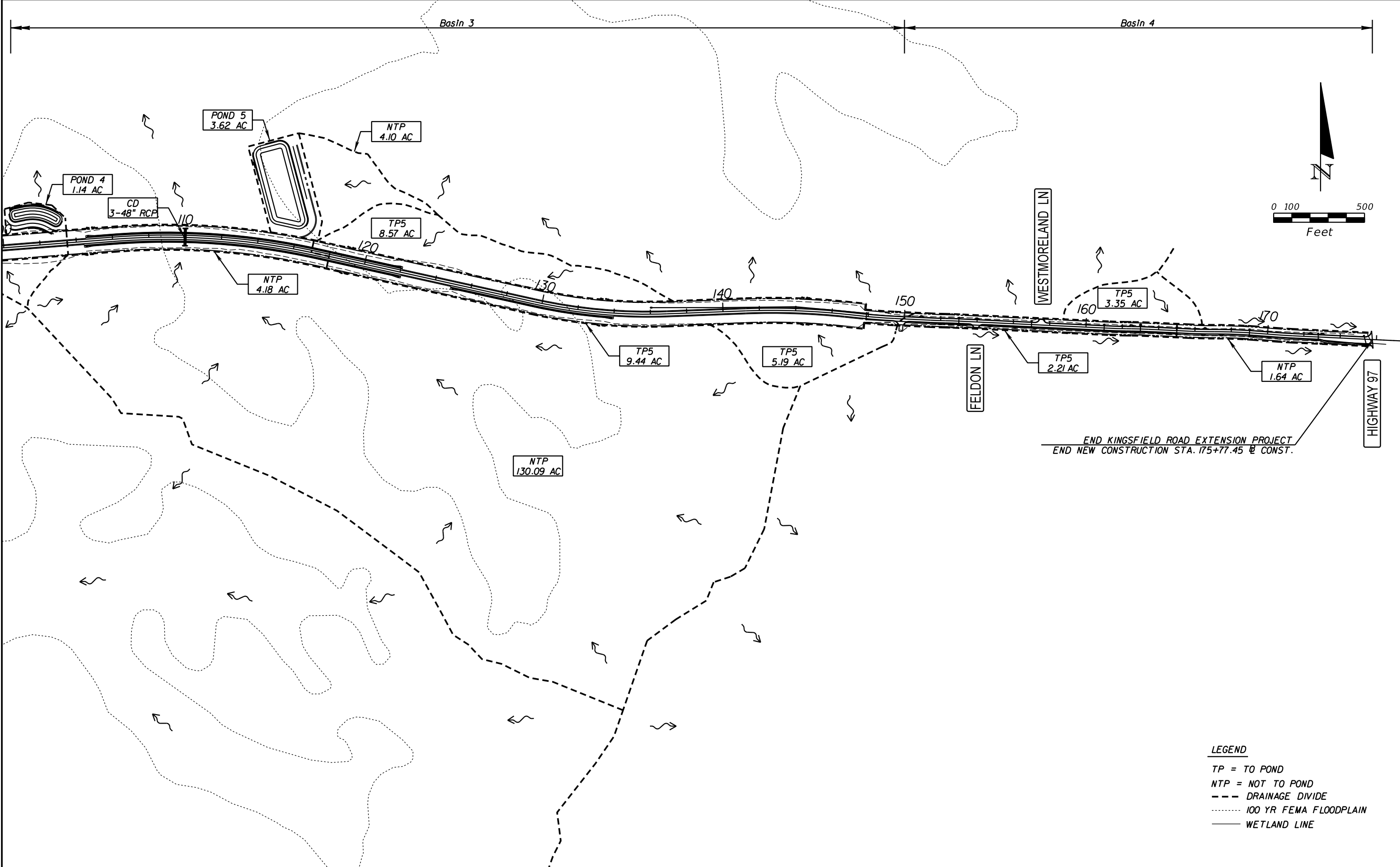

END KINGSFIELD ROAD EXTENSION PROJECT  
 END NEW CONSTRUCTION STA. 175+77.45 @ CONST.

NOTICE: THE OFFICIAL RECORD OF THIS SHEET IS THE ELECTRONIC FILE SIGNED AND SEALED UNDER RULE 61G15-23.003, F.A.C.

| REVISIONS |             |      |             |
|-----------|-------------|------|-------------|
| DATE      | DESCRIPTION | DATE | DESCRIPTION |
|           |             |      |             |

**Hatch Mott MacDonald**  
 Post Office Box 2518 5111 North 12th Avenue  
 Pensacola, Florida 32513 (850) 484-6011  
 Engineer of Records: David D. Skipper, P.E. \*58972



**Board of County Commissioners**  
 Escambia County, Florida

| ROAD NO. | COUNTY   | FINANCIAL PROJECT ID |
|----------|----------|----------------------|
|          | ESCAMBIA |                      |

**DRAINAGE MAP OVERVIEW**

SHEET NO.

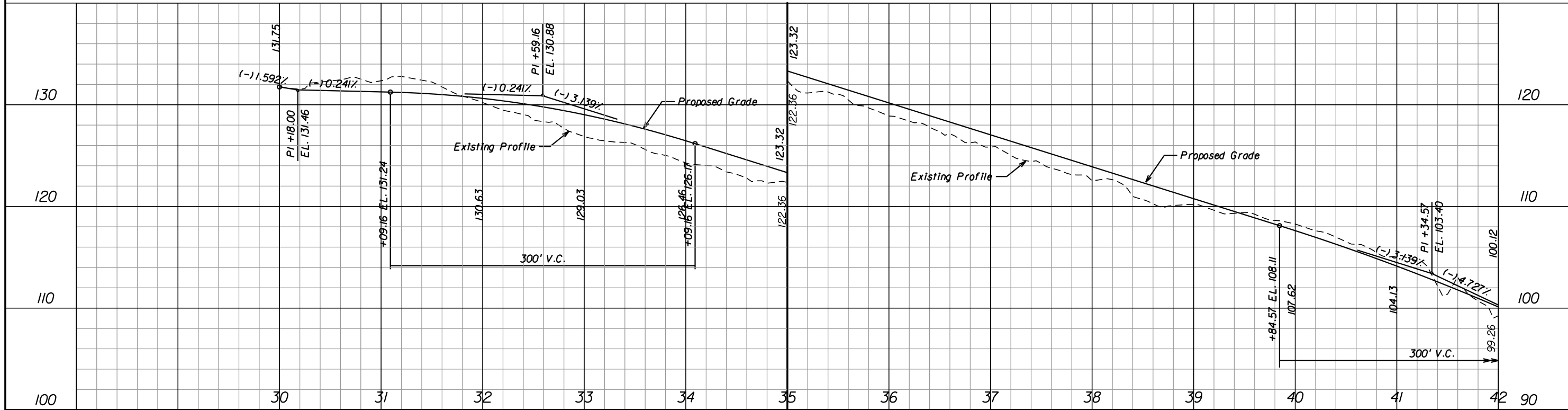
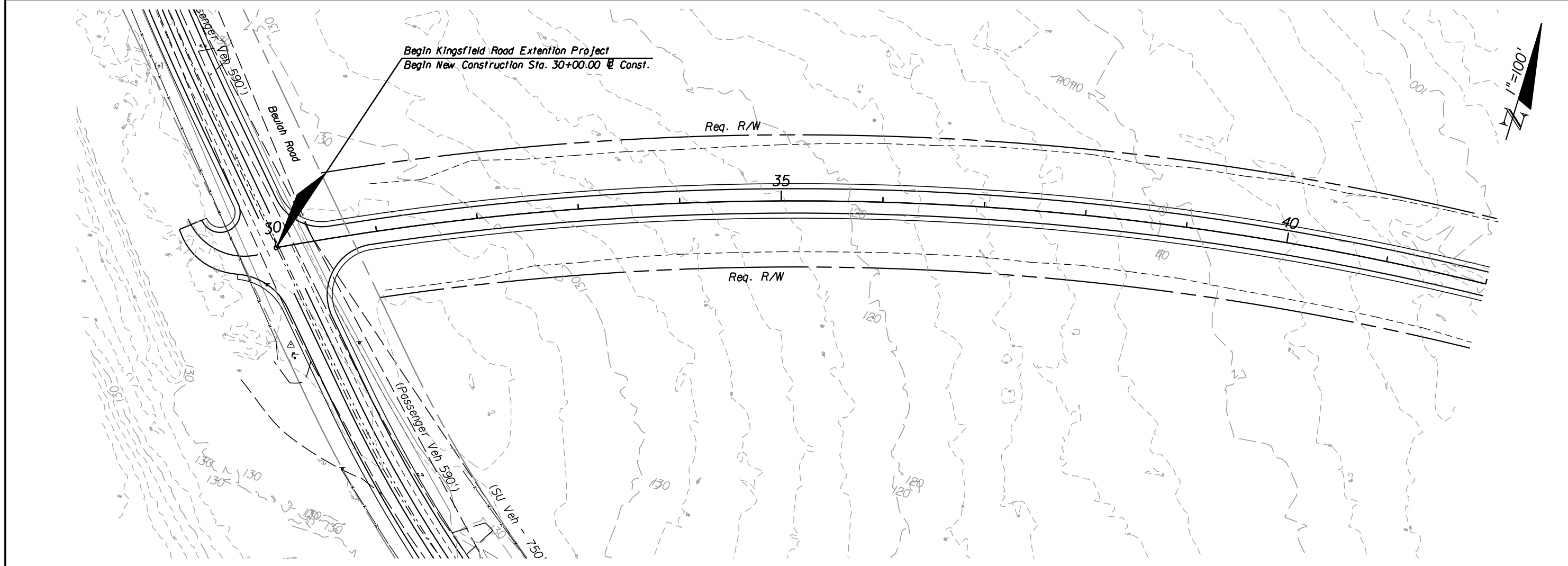

| REVISIONS |             |      |             |
|-----------|-------------|------|-------------|
| DATE      | DESCRIPTION | DATE | DESCRIPTION |
|           |             |      |             |

**Hatch Mott MacDonald**  
 Post Office Box 2518 5111 North 12th Avenue  
 Pensacola, Florida 32513 (850) 484-6011  
 Engineer of Records: David D. Skipper, P.E. \*58972



**Board of County Commissioners**  
 Escambia County, Florida

|          |          |                      |
|----------|----------|----------------------|
| ROAD NO. | COUNTY   | FINANCIAL PROJECT ID |
|          | ESCAMBIA |                      |

**PLAN & PROFILE**

SHEET NO.

NOTICE: THE OFFICIAL RECORD OF THIS SHEET IS THE ELECTRONIC FILE SIGNED AND SEALED UNDER RULE 61G15-23.003, F.A.C.

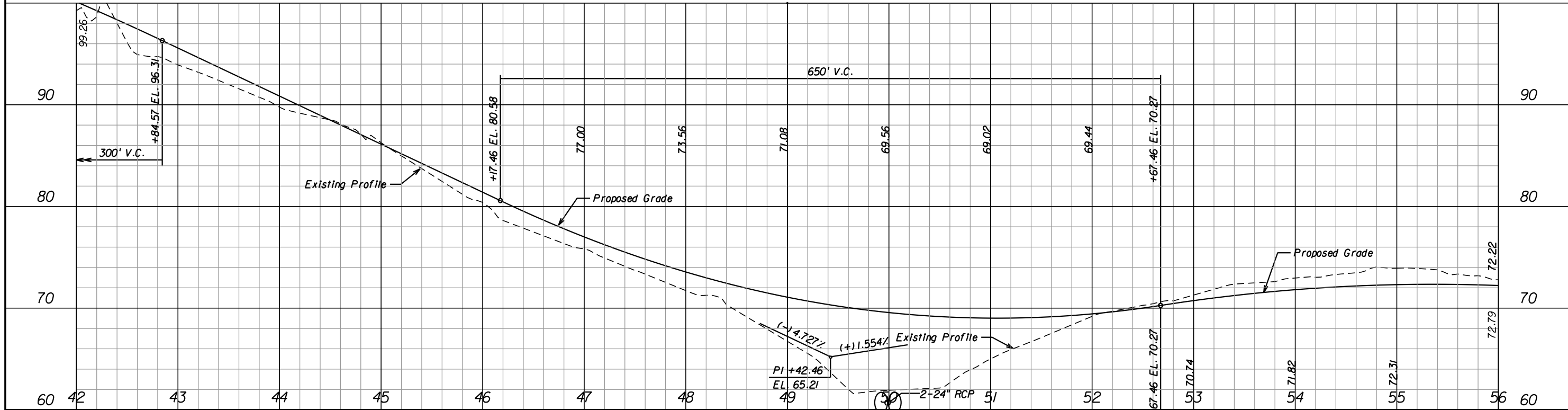
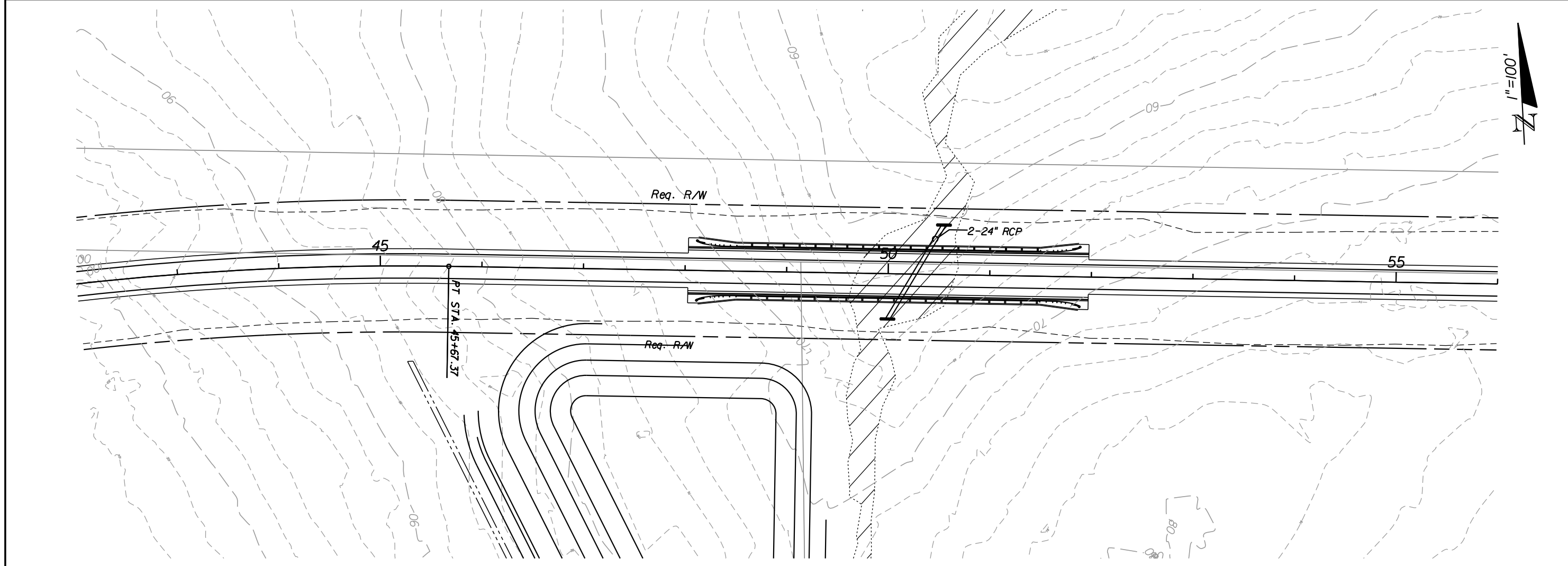

| REVISIONS |             |      |             |
|-----------|-------------|------|-------------|
| DATE      | DESCRIPTION | DATE | DESCRIPTION |
|           |             |      |             |

**Hatch Mott MacDonald**  
 Post Office Box 2518 5111 North 12th Avenue  
 Pensacola, Florida 32513 (850) 484-6011  
 Engineer of Records: David D. Skipper, P.E. \*58972



**Board of County Commissioners**  
 Escambia County, Florida

|          |          |                      |
|----------|----------|----------------------|
| ROAD NO. | COUNTY   | FINANCIAL PROJECT ID |
|          | ESCAMBIA |                      |

**PLAN & PROFILE**

SHEET NO.

NOTICE: THE OFFICIAL RECORD OF THIS SHEET IS THE ELECTRONIC FILE SIGNED AND SEALED UNDER RULE 61G15-23.003, F.A.C.



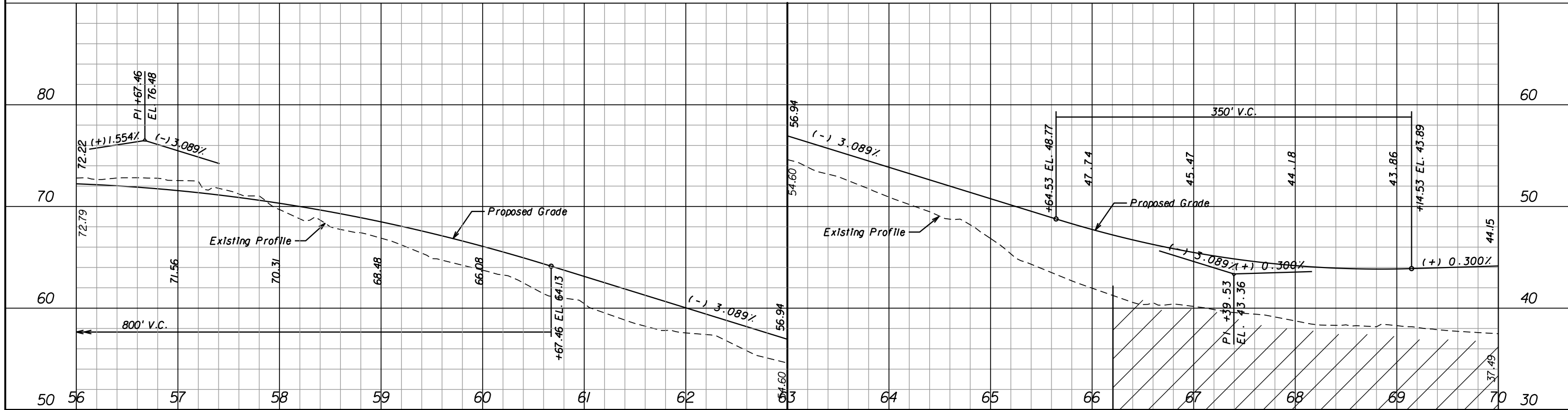
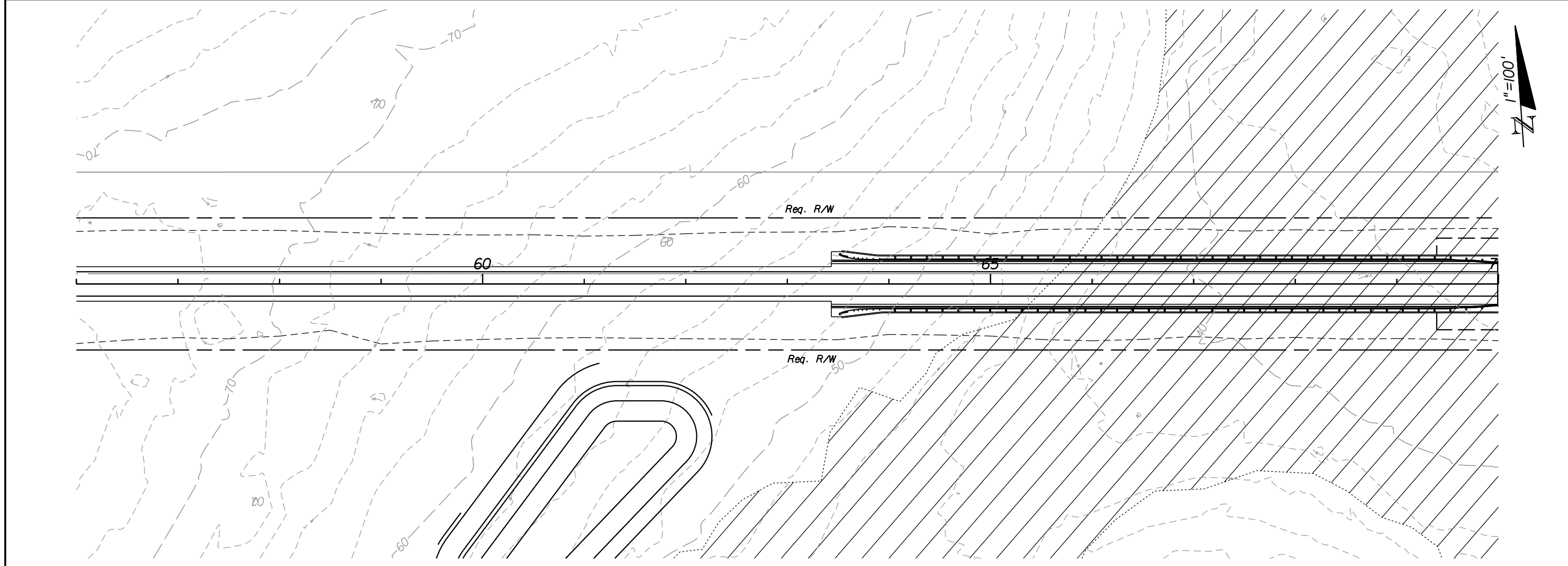

| REVISIONS |             |      |             |
|-----------|-------------|------|-------------|
| DATE      | DESCRIPTION | DATE | DESCRIPTION |
|           |             |      |             |

**Hatch Mott MacDonald**  
 Post Office Box 2518 5111 North 12th Avenue  
 Pensacola, Florida 32513 (850) 484-6011  
 Engineer of Records: David D. Skipper, P.E. \*58972



**Board of County Commissioners**  
 Escambia County, Florida

|          |          |                      |
|----------|----------|----------------------|
| ROAD NO. | COUNTY   | FINANCIAL PROJECT ID |
|          | ESCAMBIA |                      |

**PLAN & PROFILE**

SHEET NO.

NOTICE: THE OFFICIAL RECORD OF THIS SHEET IS THE ELECTRONIC FILE SIGNED AND SEALED UNDER RULE 61G15-23.003, F.A.C.

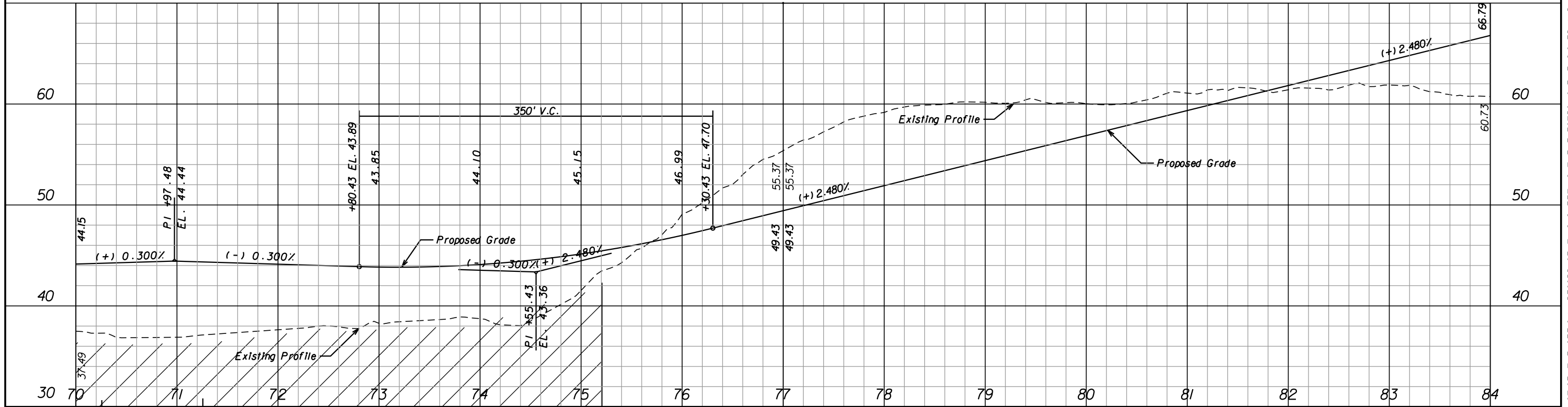
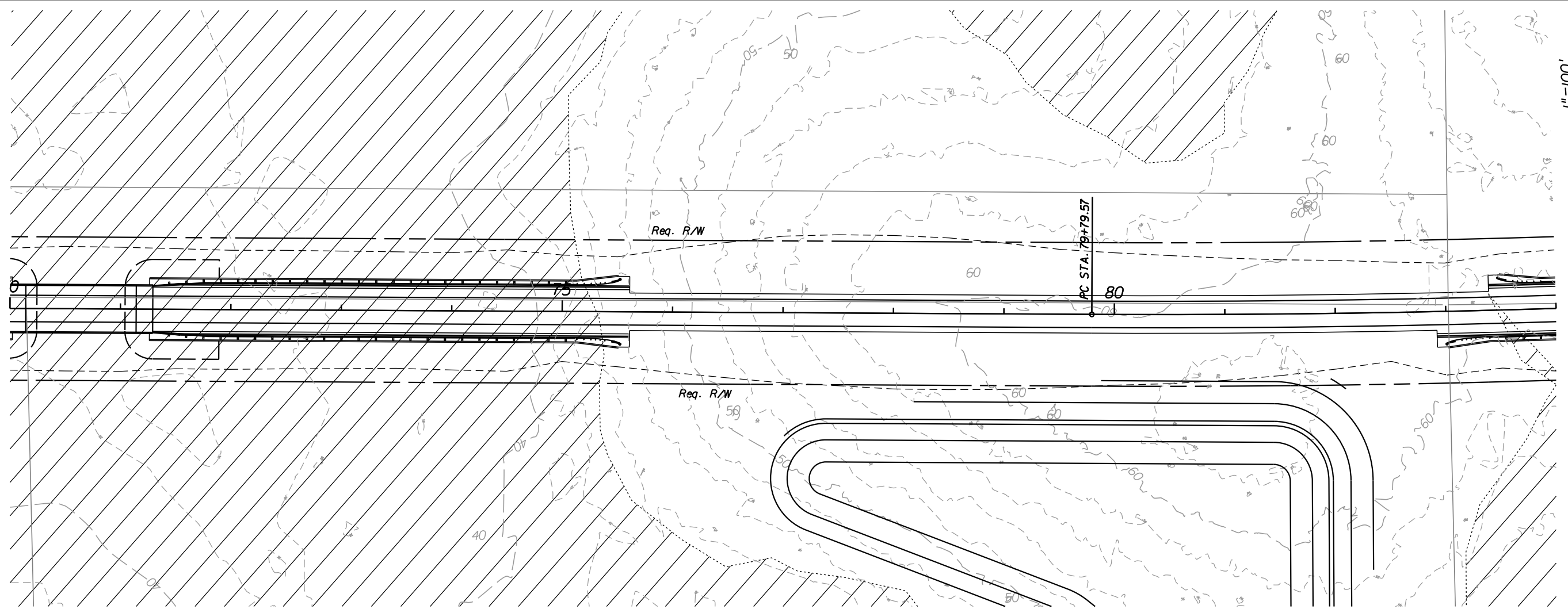

| REVISIONS |             |      |             |
|-----------|-------------|------|-------------|
| DATE      | DESCRIPTION | DATE | DESCRIPTION |
|           |             |      |             |

**Hatch Mott MacDonald**  
 Post Office Box 2518 5111 North 12th Avenue  
 Pensacola, Florida 32513 (850) 484-6011  
 Engineer of Records: David D. Skipper, P.E. \*58972



**Board of County Commissioners**  
 Escambia County, Florida

|          |          |                      |
|----------|----------|----------------------|
| ROAD NO. | COUNTY   | FINANCIAL PROJECT ID |
|          | ESCAMBIA |                      |

**PLAN & PROFILE**

SHEET NO.

NOTICE: THE OFFICIAL RECORD OF THIS SHEET IS THE ELECTRONIC FILE SIGNED AND SEALED UNDER RULE 61G15-23.003, F.A.C.

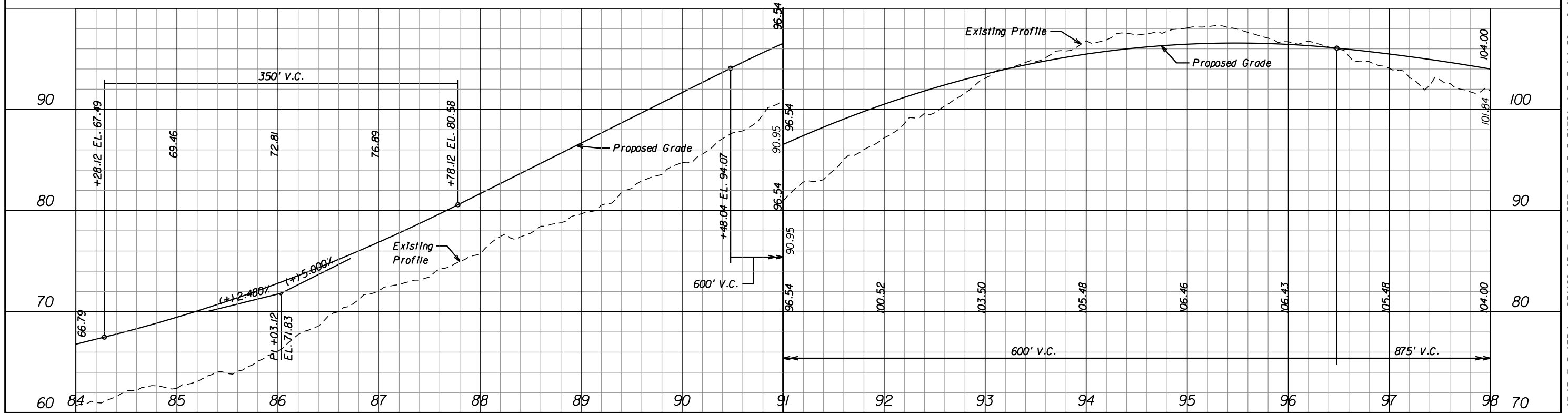
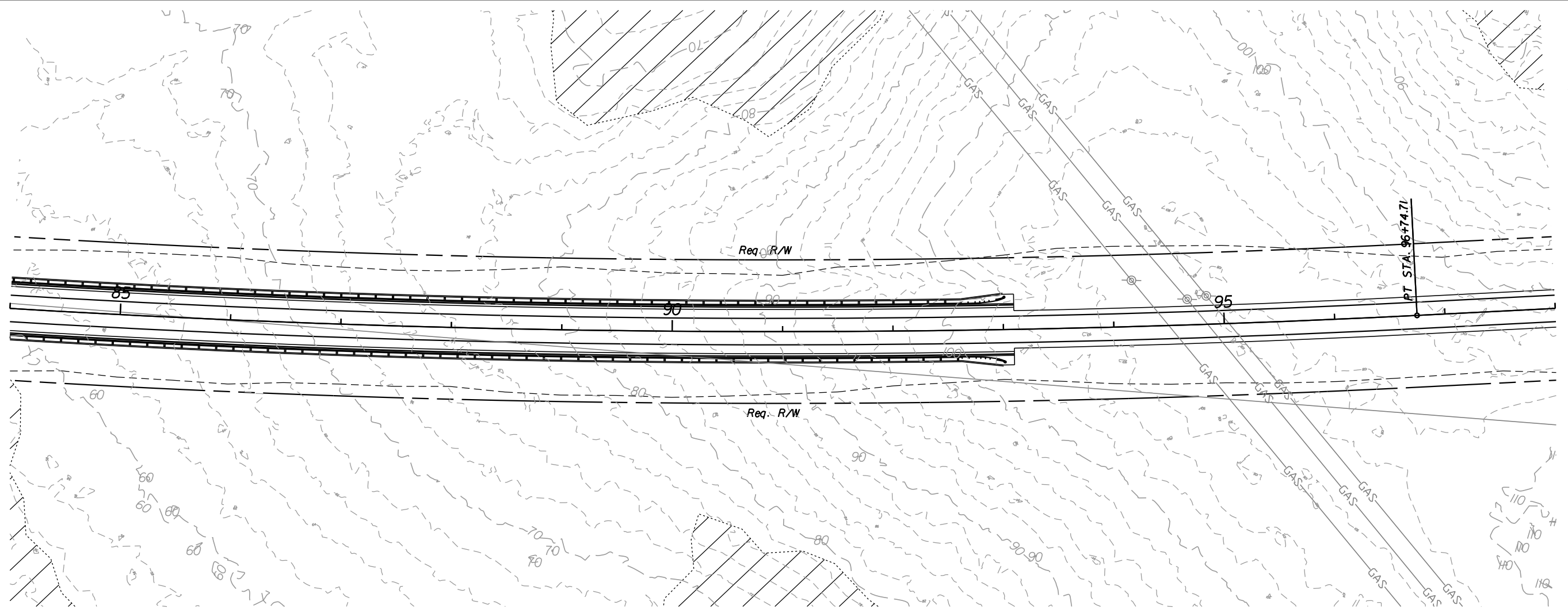

| REVISIONS |             |      |             |
|-----------|-------------|------|-------------|
| DATE      | DESCRIPTION | DATE | DESCRIPTION |
|           |             |      |             |

**Hatch Mott MacDonald**  
 Post Office Box 2518 5111 North 12th Avenue  
 Pensacola, Florida 32513 (850) 484-6011  
 Engineer of Records: David D. Skipper, P.E. \*58972



**Board of County Commissioners**  
 Escambia County, Florida

|          |          |                      |
|----------|----------|----------------------|
| ROAD NO. | COUNTY   | FINANCIAL PROJECT ID |
|          | ESCAMBIA |                      |

**PLAN & PROFILE**

SHEET NO.

NOTICE: THE OFFICIAL RECORD OF THIS SHEET IS THE ELECTRONIC FILE SIGNED AND SEALED UNDER RULE 61G15-23.003, F.A.C.

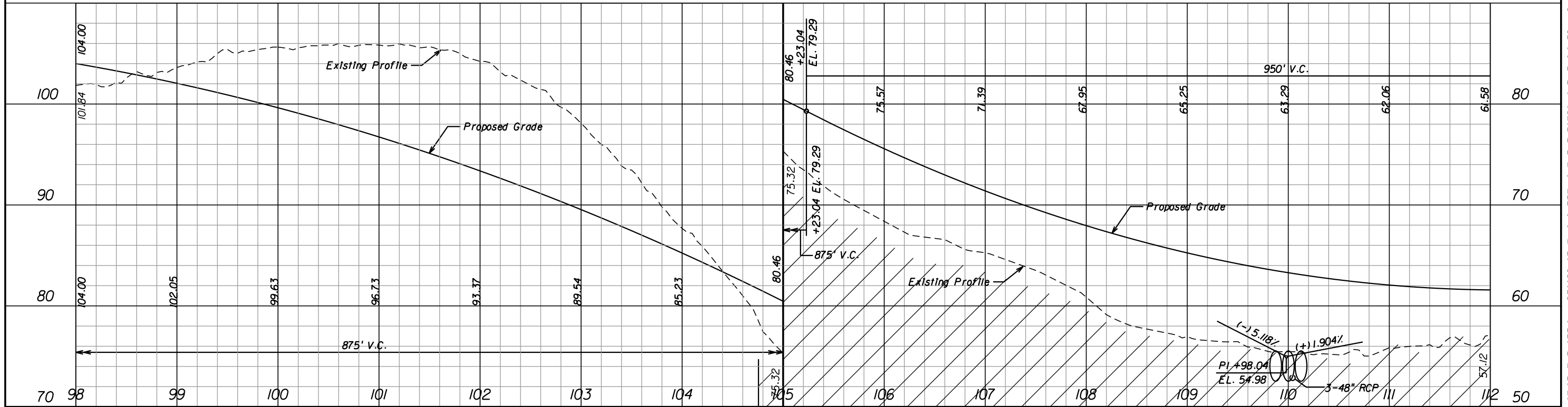
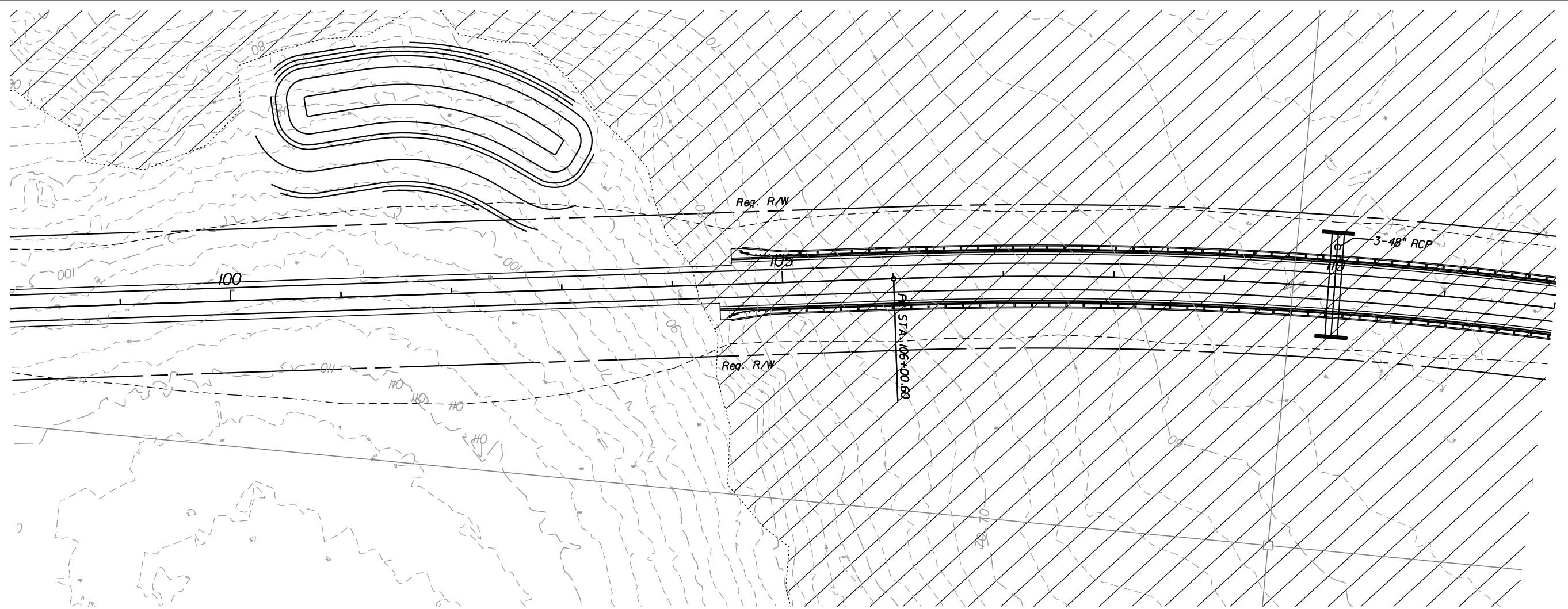

| REVISIONS |             |      |             |
|-----------|-------------|------|-------------|
| DATE      | DESCRIPTION | DATE | DESCRIPTION |
|           |             |      |             |

**Hatch Mott MacDonald**  
 Post Office Box 2518 5111 North 12th Avenue  
 Pensacola, Florida 32513 (850) 484-6011  
 Engineer of Records: David D. Skipper, P.E. \*58972



**Board of County Commissioners**  
 Escambia County, Florida

|          |          |                      |
|----------|----------|----------------------|
| ROAD NO. | COUNTY   | FINANCIAL PROJECT ID |
|          | ESCAMBIA |                      |

**PLAN & PROFILE**

DATE: 7/24/2012 3:47:53 PM  
 FILE: p:\296696\drawings\Roadway\plpr rd06.dgn

NOTICE: THE OFFICIAL RECORD OF THIS SHEET IS THE ELECTRONIC FILE SIGNED AND SEALED UNDER RULE 61G15-23.003, F.A.C.

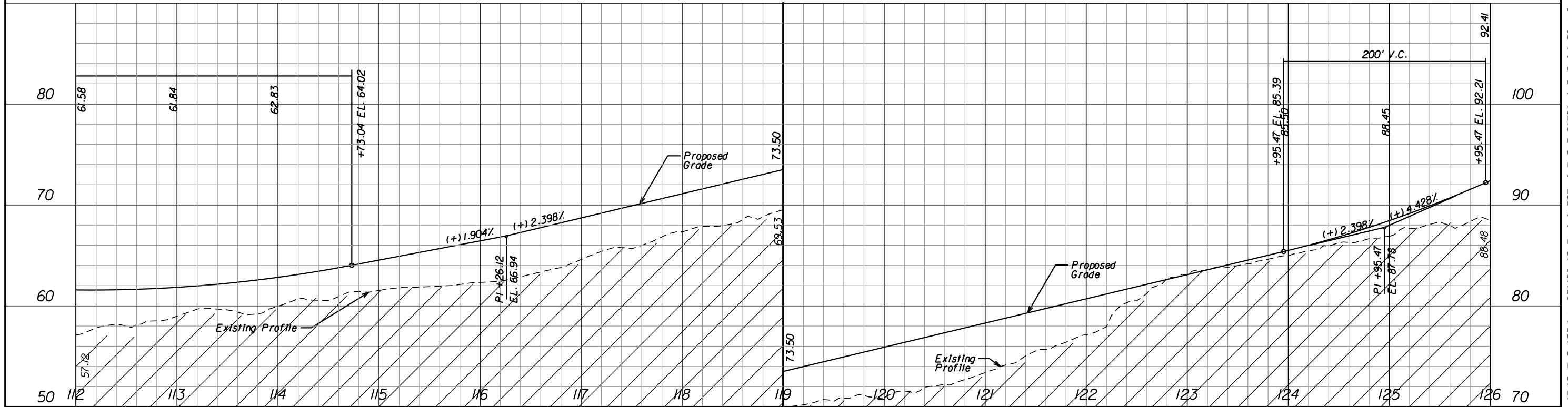
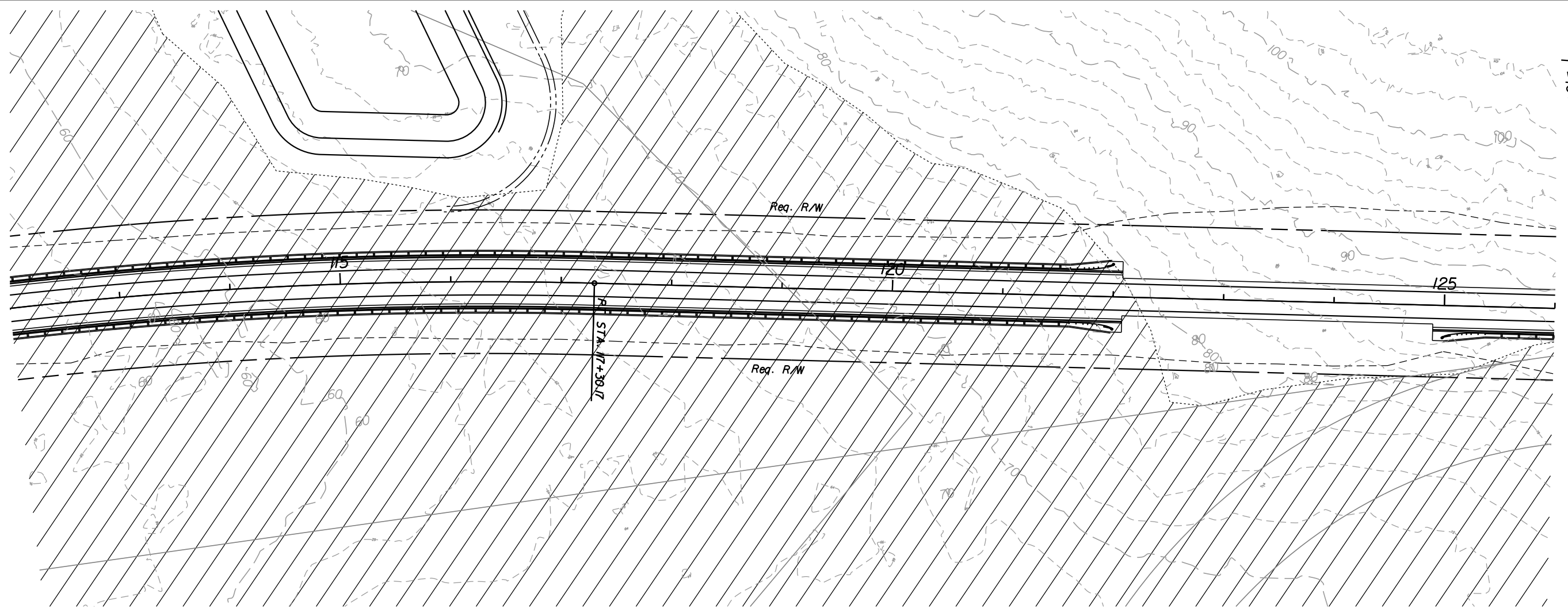

| REVISIONS |             |      |             |
|-----------|-------------|------|-------------|
| DATE      | DESCRIPTION | DATE | DESCRIPTION |
|           |             |      |             |

**Hatch Mott MacDonald**  
 Post Office Box 2518 5111 North 12th Avenue  
 Pensacola, Florida 32513 (850) 484-6011  
 Engineer of Records: David D. Skipper, P.E. \*58972



**Board of County Commissioners**  
 Escambia County, Florida

|          |          |                      |
|----------|----------|----------------------|
| ROAD NO. | COUNTY   | FINANCIAL PROJECT ID |
|          | ESCAMBIA |                      |

**PLAN & PROFILE**

SHEET NO.  

NOTICE: THE OFFICIAL RECORD OF THIS SHEET IS THE ELECTRONIC FILE SIGNED AND SEALED UNDER RULE 61G15-23.003, F.A.C.

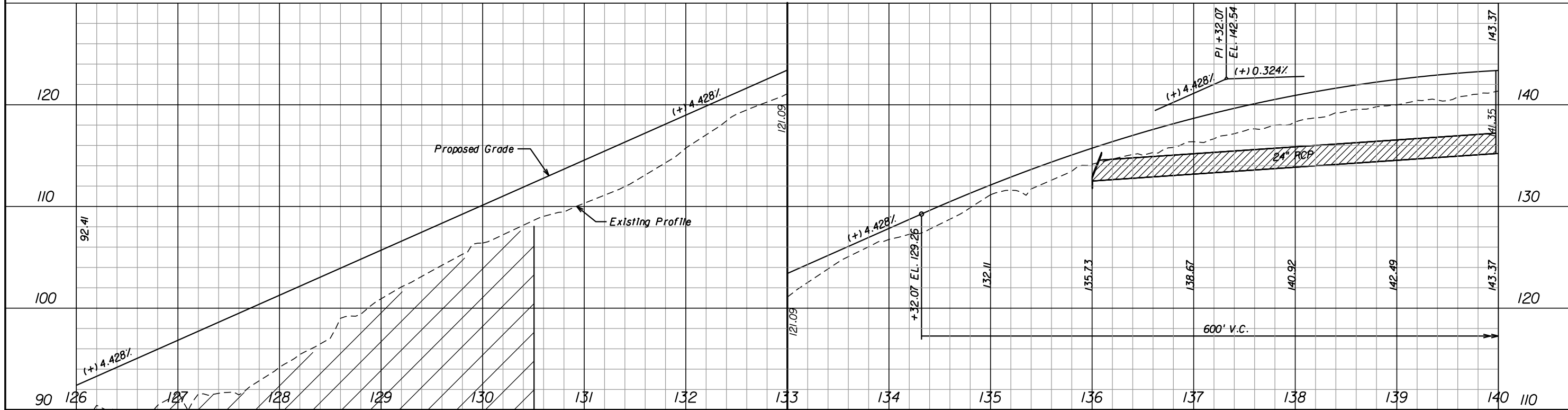
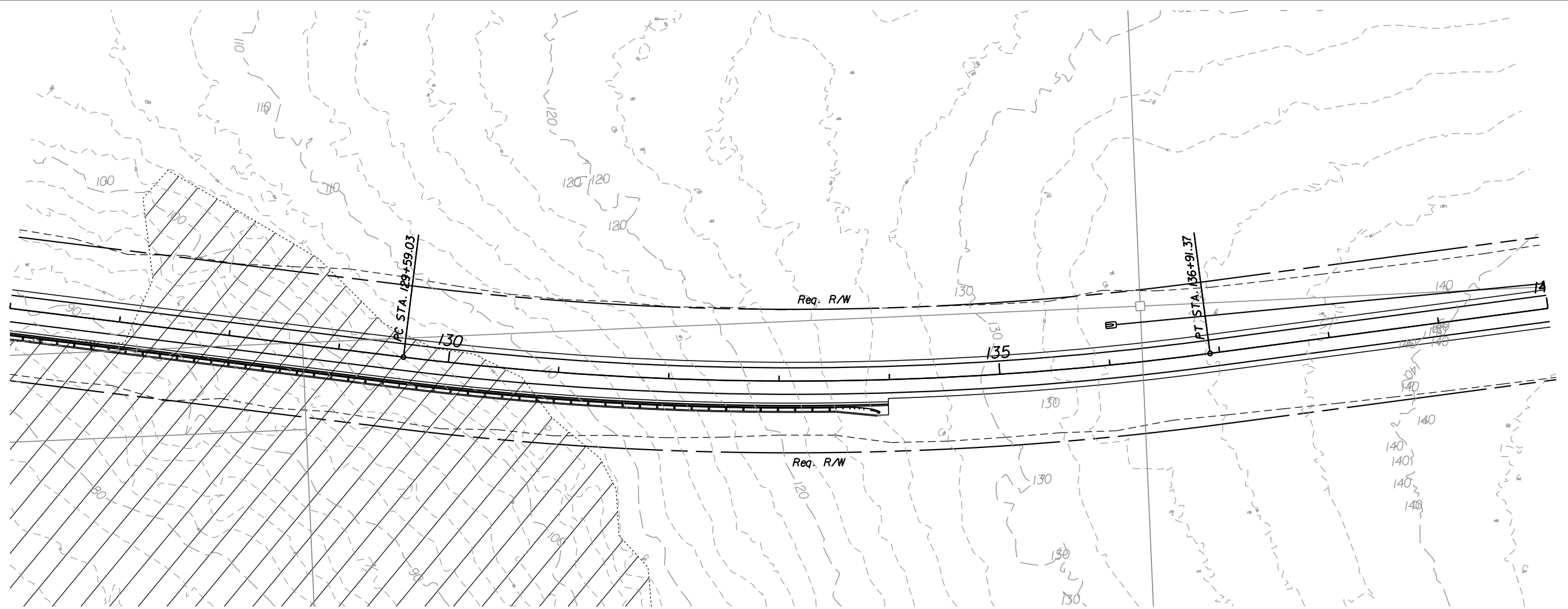

| REVISIONS |             |      |             |
|-----------|-------------|------|-------------|
| DATE      | DESCRIPTION | DATE | DESCRIPTION |
|           |             |      |             |

**Hatch Mott MacDonald**  
 Post Office Box 2518 5111 North 12th Avenue  
 Pensacola, Florida 32513 (850) 484-6011  
 Engineer of Records: David D. Skipper, P.E. \*58972



**Board of County Commissioners**  
 Escambia County, Florida

|          |          |                      |
|----------|----------|----------------------|
| ROAD NO. | COUNTY   | FINANCIAL PROJECT ID |
|          | ESCAMBIA |                      |

**PLAN & PROFILE**

DATE: 7/24/2012 3:48:02 PM  
 FILE: p:\296696\drawings\Roadway\plpr rd08.dgn

SHEET NO. 110

NOTICE: THE OFFICIAL RECORD OF THIS SHEET IS THE ELECTRONIC FILE SIGNED AND SEALED UNDER RULE 61G15-23.003, F.A.C.

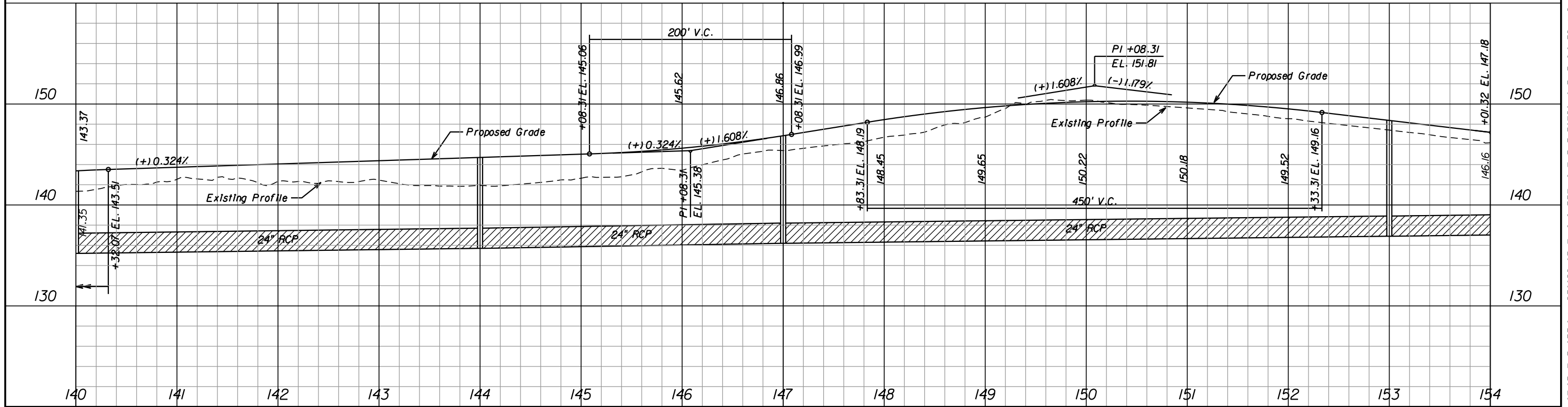
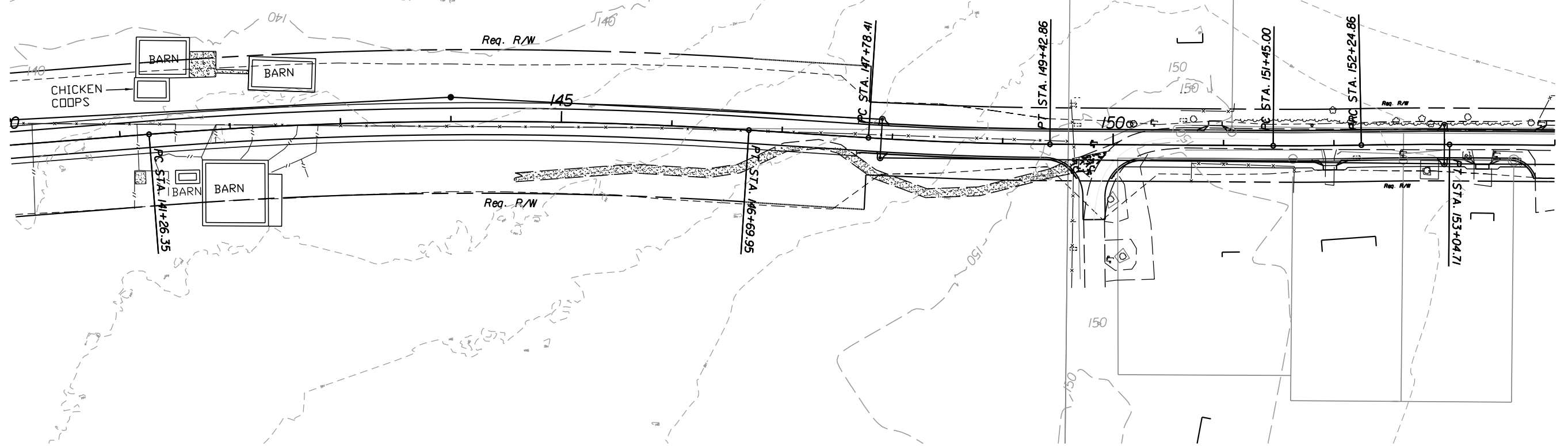
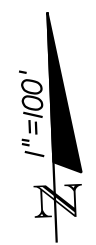

| REVISIONS |             |      |             |
|-----------|-------------|------|-------------|
| DATE      | DESCRIPTION | DATE | DESCRIPTION |
|           |             |      |             |

**Hatch Mott MacDonald**  
 Post Office Box 2518 5111 North 12th Avenue  
 Pensacola, Florida 32513 (850) 484-6011  
 Engineer of Records: David D. Skipper, P.E. \*58972



**Board of County Commissioners**  
 Escambia County, Florida

|          |          |                      |
|----------|----------|----------------------|
| ROAD NO. | COUNTY   | FINANCIAL PROJECT ID |
|          | ESCAMBIA |                      |

**PLAN & PROFILE**

SHEET NO.

NOTICE: THE OFFICIAL RECORD OF THIS SHEET IS THE ELECTRONIC FILE SIGNED AND SEALED UNDER RULE 61G15-23.003, F.A.C.

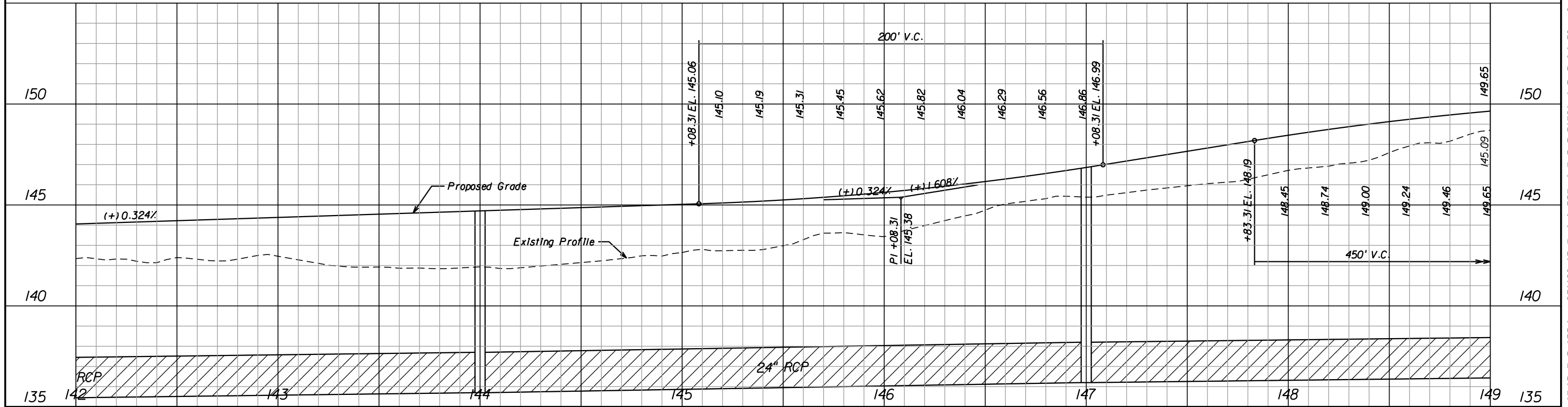
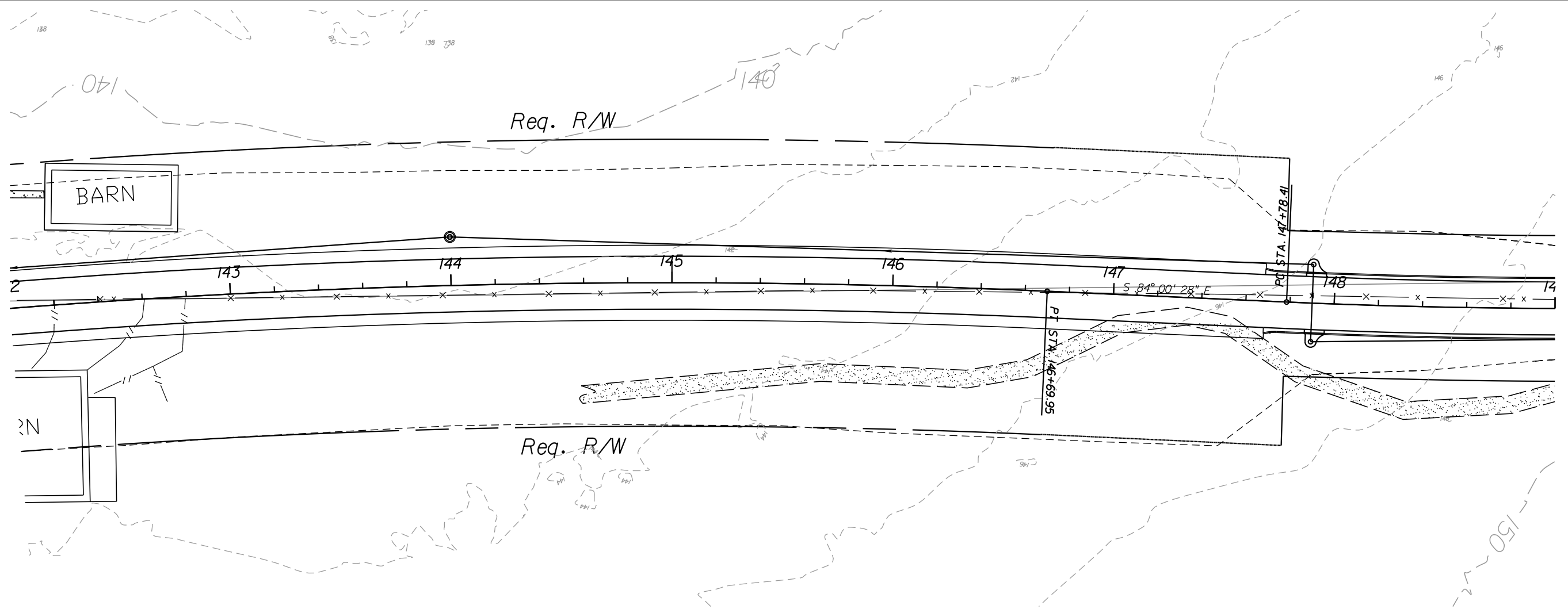

| REVISIONS |             |      |             |
|-----------|-------------|------|-------------|
| DATE      | DESCRIPTION | DATE | DESCRIPTION |
|           |             |      |             |

**Hatch Mott MacDonald**  
 Post Office Box 2518 5111 North 12th Avenue  
 Pensacola, Florida 32513 (850) 484-6011  
 Engineer of Records: David D. Skipper, P.E. \*58972



**Board of County Commissioners**  
 Escambia County, Florida

|          |          |                      |
|----------|----------|----------------------|
| ROAD NO. | COUNTY   | FINANCIAL PROJECT ID |
|          | ESCAMBIA |                      |

**PLAN & PROFILE**

SHEET NO.  

NOTICE: THE OFFICIAL RECORD OF THIS SHEET IS THE ELECTRONIC FILE SIGNED AND SEALED UNDER RULE 61G15-23.003, F.A.C.



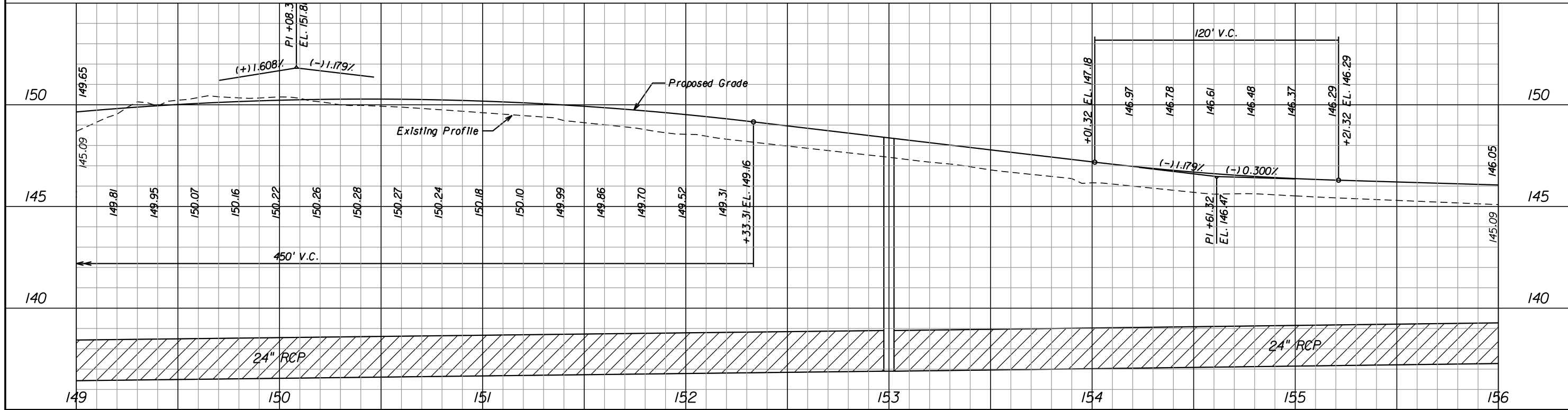
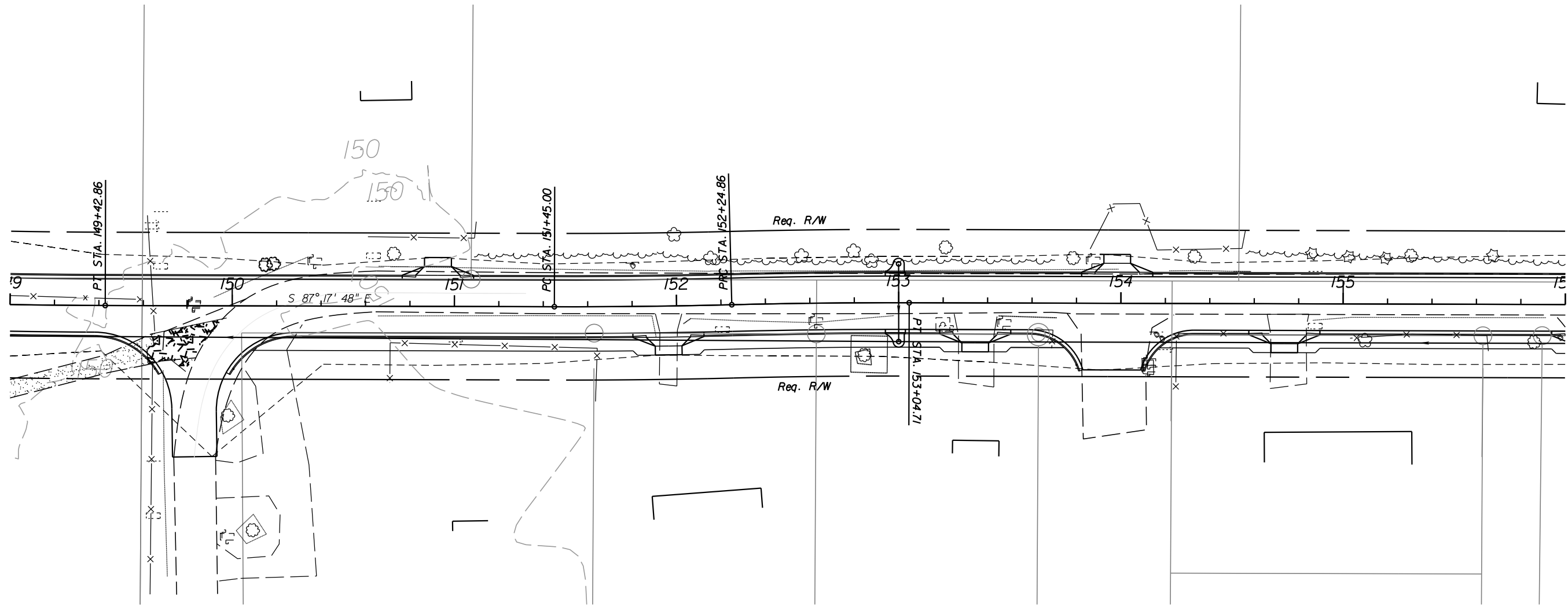

| REVISIONS |             |      |             |
|-----------|-------------|------|-------------|
| DATE      | DESCRIPTION | DATE | DESCRIPTION |
|           |             |      |             |

**Hatch Mott MacDonald**  
 Post Office Box 2518 5111 North 12th Avenue  
 Pensacola, Florida 32513 (850) 484-6011  
 Engineer of Records: David D. Skipper, P.E. \*58972



**Board of County Commissioners**  
 Escambia County, Florida

|          |          |                      |
|----------|----------|----------------------|
| ROAD NO. | COUNTY   | FINANCIAL PROJECT ID |
|          | ESCAMBIA |                      |

**PLAN & PROFILE**

SHEET NO.

NOTICE: THE OFFICIAL RECORD OF THIS SHEET IS THE ELECTRONIC FILE SIGNED AND SEALED UNDER RULE 61G15-23.003, F.A.C.

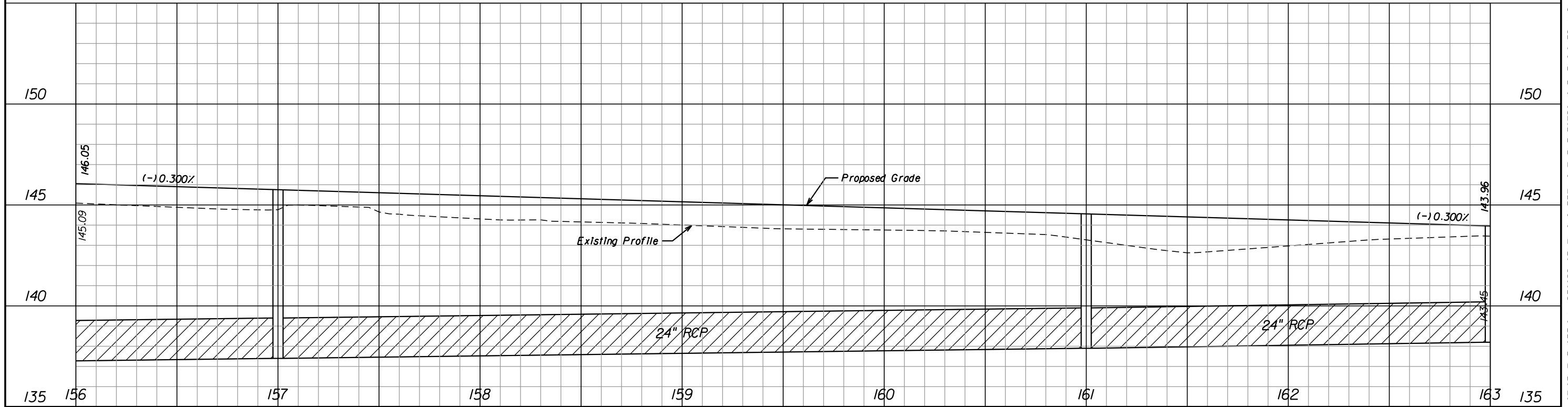
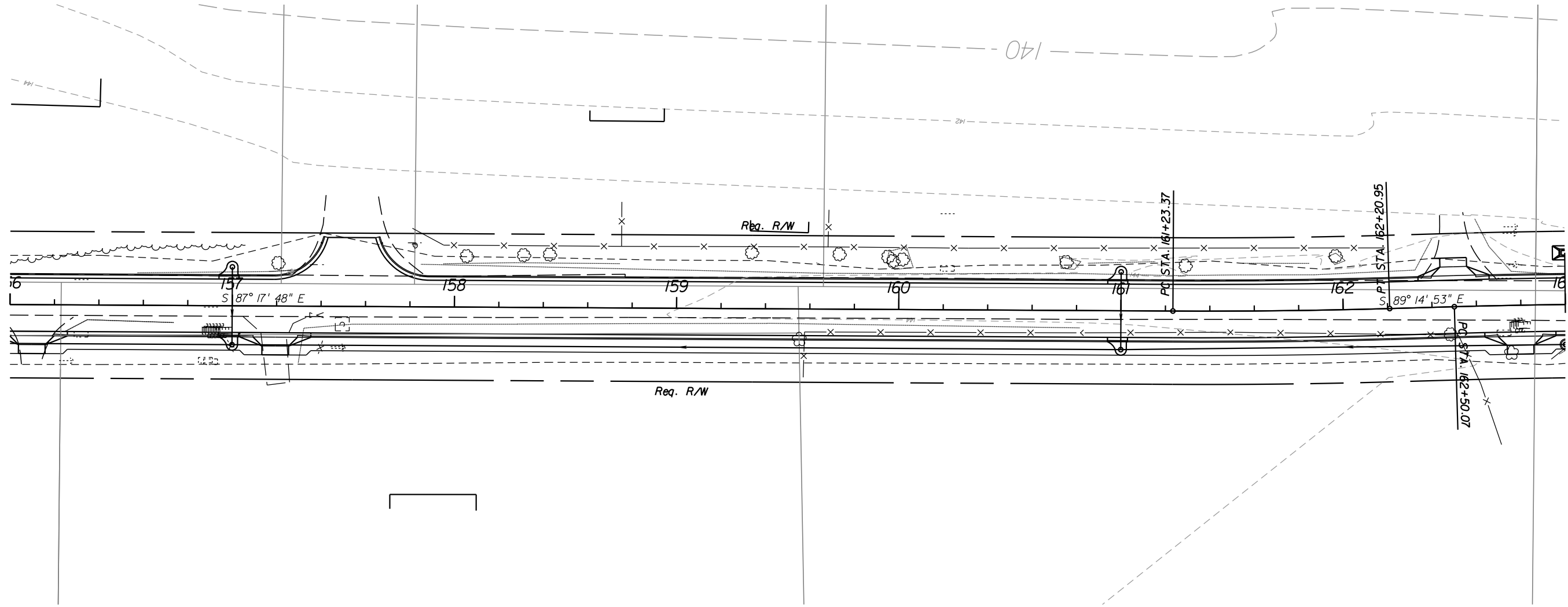

| REVISIONS |             |      |             |
|-----------|-------------|------|-------------|
| DATE      | DESCRIPTION | DATE | DESCRIPTION |
|           |             |      |             |

**Hatch Mott MacDonald**  
 Post Office Box 2518 5111 North 12th Avenue  
 Pensacola, Florida 32513 (850) 484-6011  
 Engineer of Records: David D. Skipper, P.E. \*58972



**Board of County Commissioners**  
 Escambia County, Florida

|          |          |                      |
|----------|----------|----------------------|
| ROAD NO. | COUNTY   | FINANCIAL PROJECT ID |
|          | ESCAMBIA |                      |

**PLAN & PROFILE**

SHEET NO.

NOTICE: THE OFFICIAL RECORD OF THIS SHEET IS THE ELECTRONIC FILE SIGNED AND SEALED UNDER RULE 61G15-23.003, F.A.C.

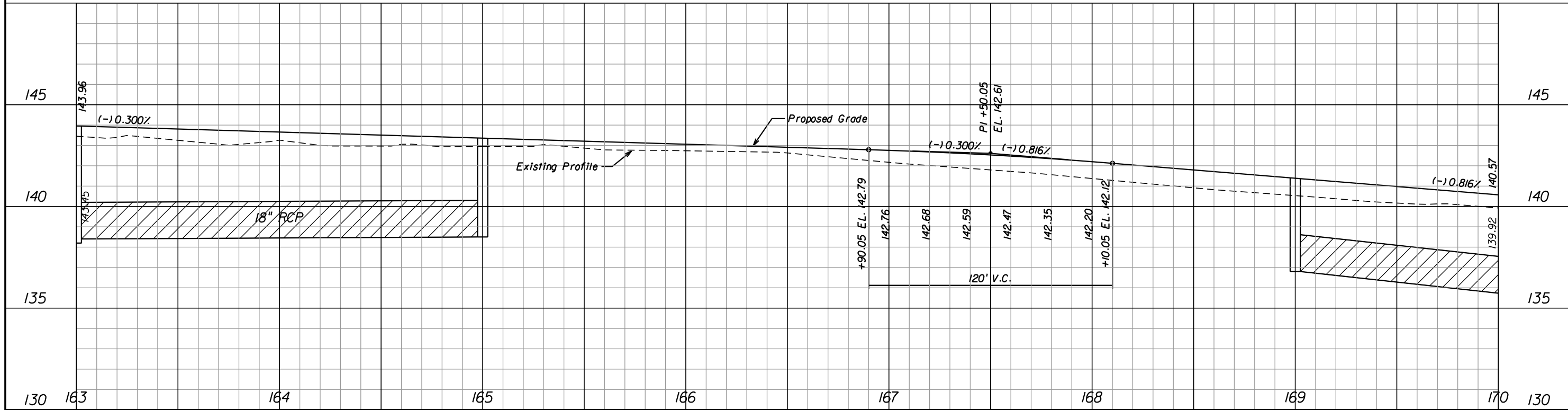
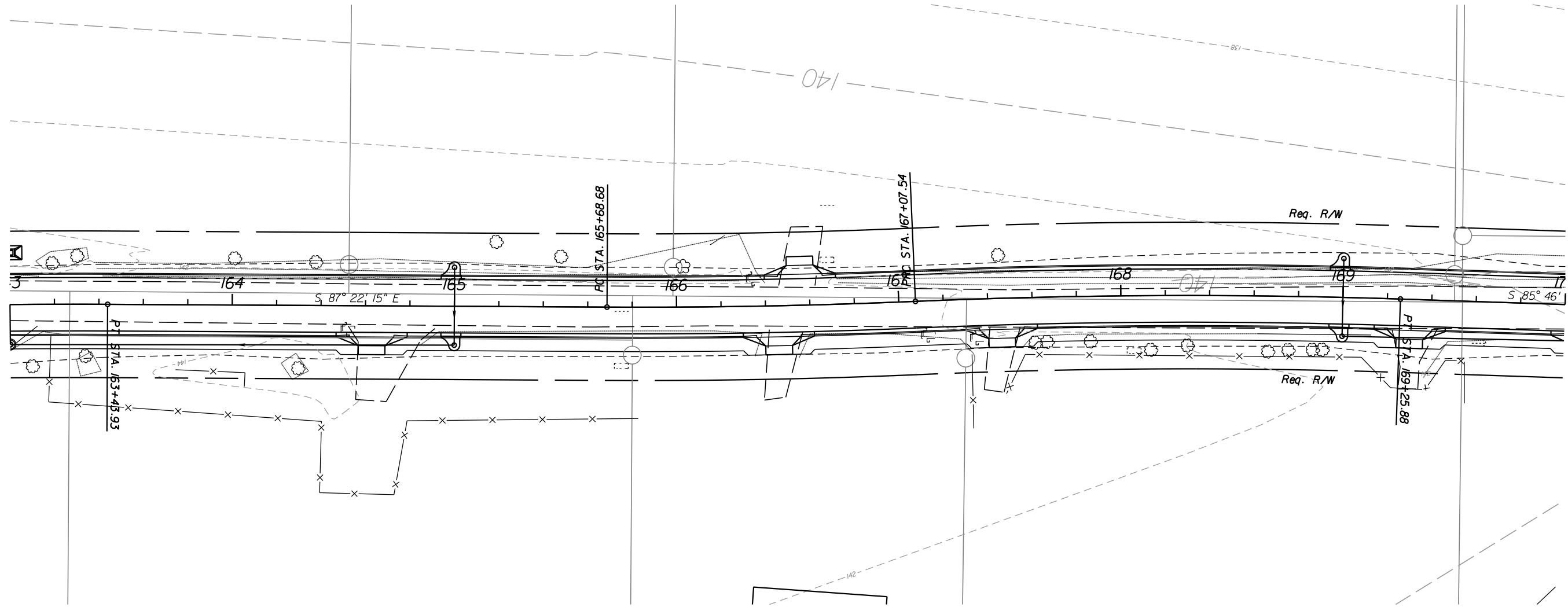

| REVISIONS |             |      |             |
|-----------|-------------|------|-------------|
| DATE      | DESCRIPTION | DATE | DESCRIPTION |
|           |             |      |             |

**Hatch Mott MacDonald**  
 Post Office Box 2518 5111 North 12th Avenue  
 Pensacola, Florida 32513 (850) 484-6011  
 Engineer of Records: David D. Skipper, P.E. \*58972



**Board of County Commissioners**  
 Escambia County, Florida

|          |          |                      |
|----------|----------|----------------------|
| ROAD NO. | COUNTY   | FINANCIAL PROJECT ID |
|          | ESCAMBIA |                      |

**PLAN & PROFILE**

SHEET NO.

NOTICE: THE OFFICIAL RECORD OF THIS SHEET IS THE ELECTRONIC FILE SIGNED AND SEALED UNDER RULE 61G15-23.003, F.A.C.

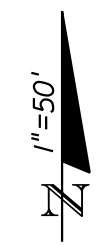

End Kingsfield Road Extension Project  
Sta. 175+77.45 to Const. and Highway 97

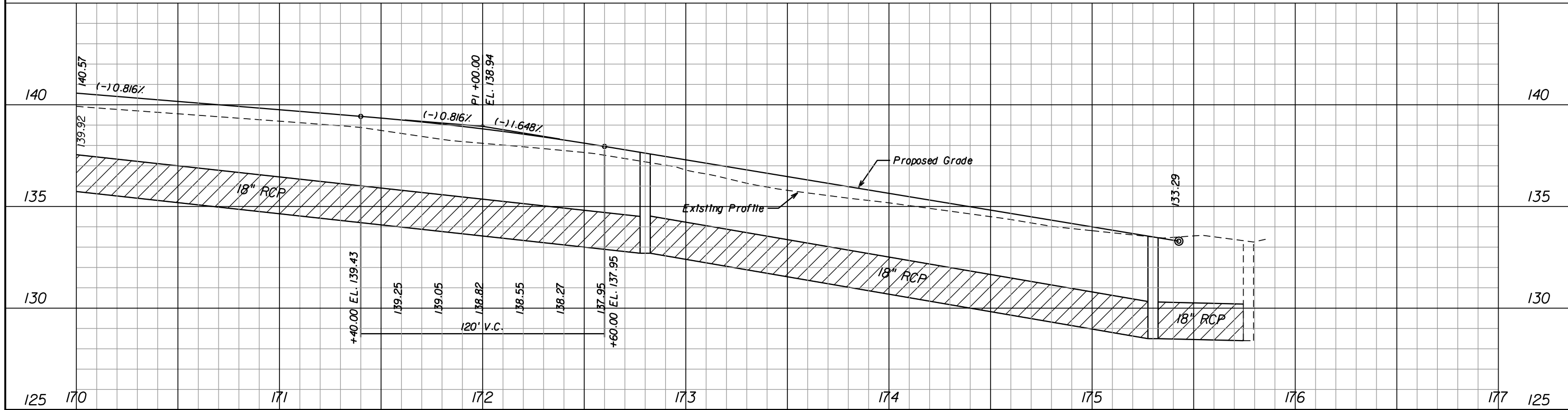
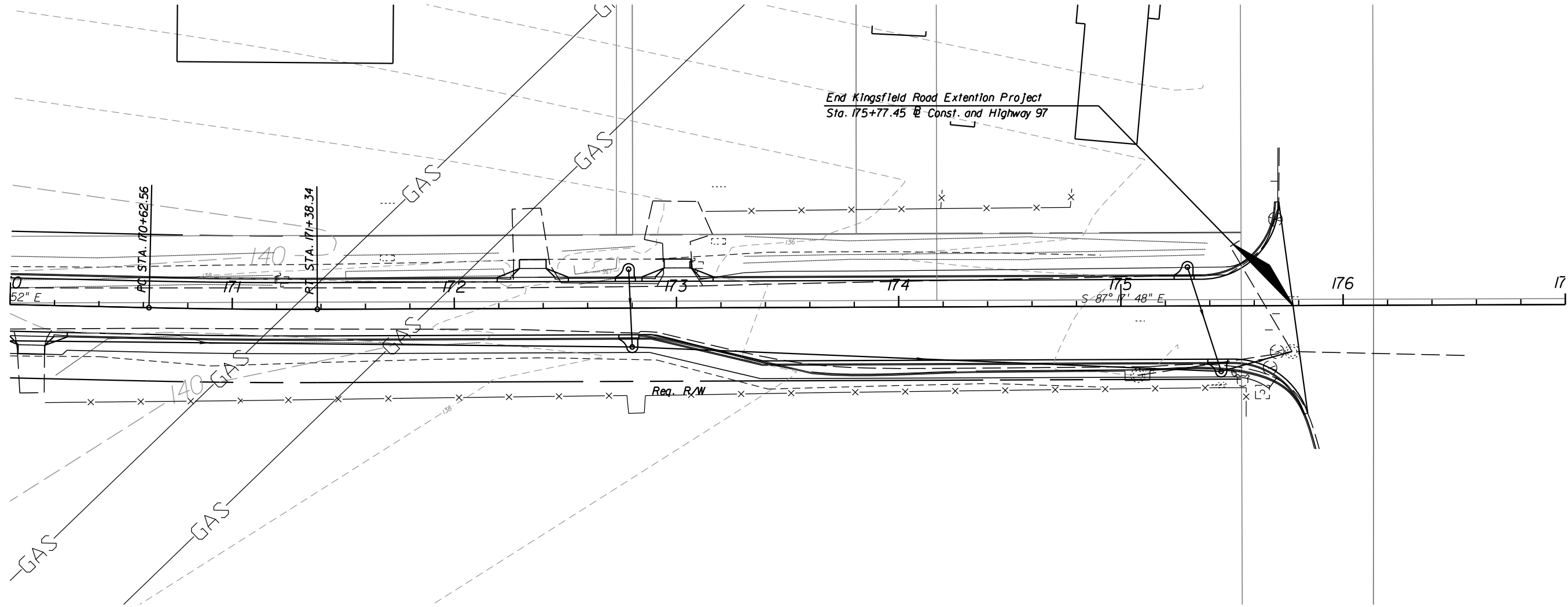

| REVISIONS |             |      |             |
|-----------|-------------|------|-------------|
| DATE      | DESCRIPTION | DATE | DESCRIPTION |
|           |             |      |             |

**Hatch Mott MacDonald**  
 Post Office Box 2518 5111 North 12th Avenue  
 Pensacola, Florida 32513 (850) 484-6011  
 Engineer of Records: David D. Skipper, P.E. \*58972



**Board of County Commissioners**  
 Escambia County, Florida

|          |          |                      |
|----------|----------|----------------------|
| ROAD NO. | COUNTY   | FINANCIAL PROJECT ID |
|          | ESCAMBIA |                      |

**PLAN & PROFILE**

DATE: 7/24/2012 3:48:31 PM p:\296696\drawings\Roadway\plpr rd14.dgn

SHEET NO. 125

NOTICE: THE OFFICIAL RECORD OF THIS SHEET IS THE ELECTRONIC FILE SIGNED AND SEALED UNDER RULE 61G15-23.003, F.A.C.

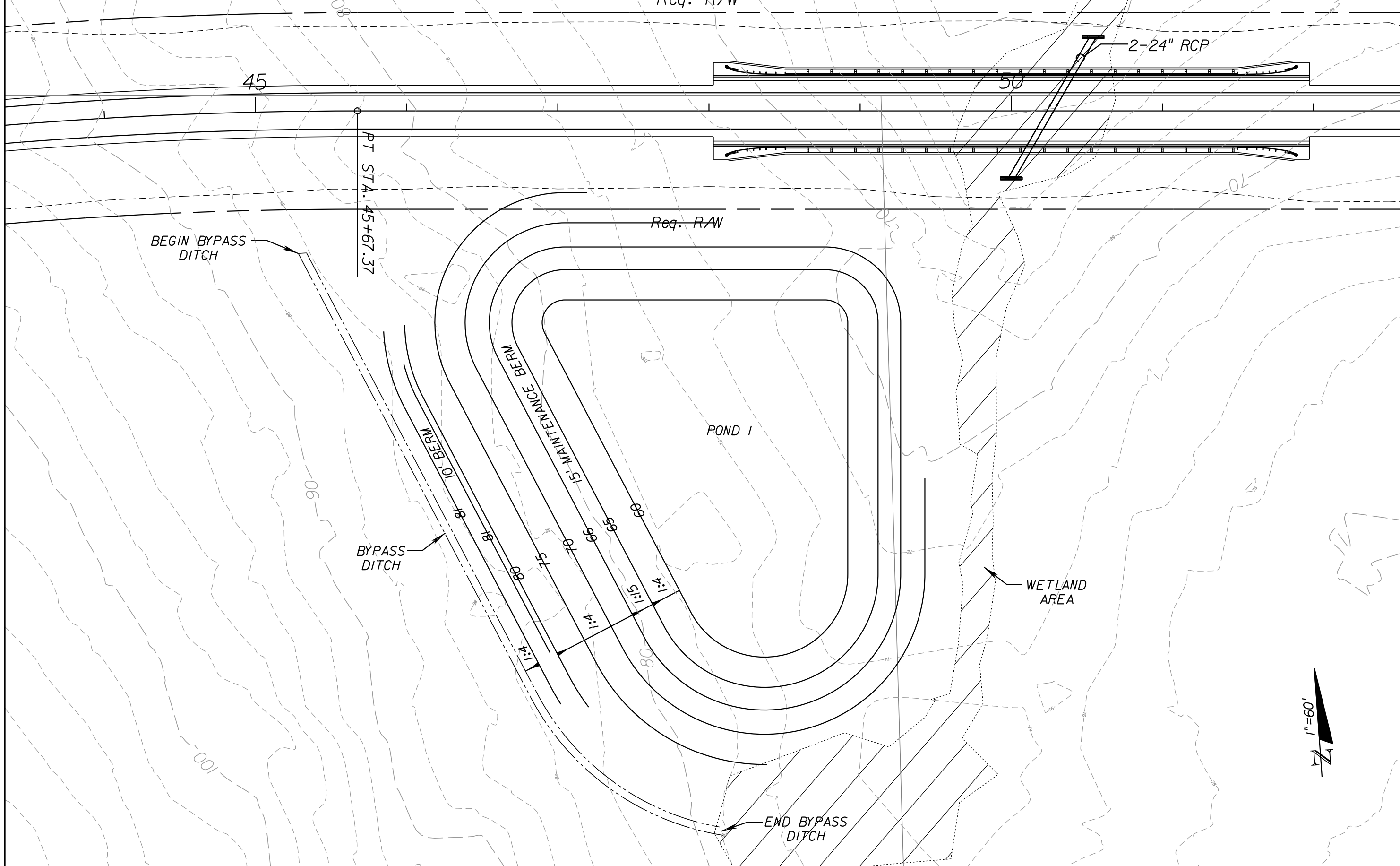

NOTICE: THE OFFICIAL RECORD OF THIS SHEET IS THE ELECTRONIC FILE SIGNED AND SEALED UNDER RULE 61G15-23.003, F.A.C.

| REVISIONS |             |      |             |
|-----------|-------------|------|-------------|
| DATE      | DESCRIPTION | DATE | DESCRIPTION |
|           |             |      |             |

**Hatch Mott MacDonald**  
 Post Office Box 2518 5111 North 12th Avenue  
 Pensacola, Florida 32513 (850) 484-6011  
 Engineer of Records: David D. Skipper, P.E. \*58972



**Board of County Commissioners**  
 Escambia County, Florida

|          |          |                      |
|----------|----------|----------------------|
| ROAD NO. | COUNTY   | FINANCIAL PROJECT ID |
|          | ESCAMBIA |                      |

**POND DETAIL**  
**POND 1**

|           |
|-----------|
| SHEET NO. |
|           |

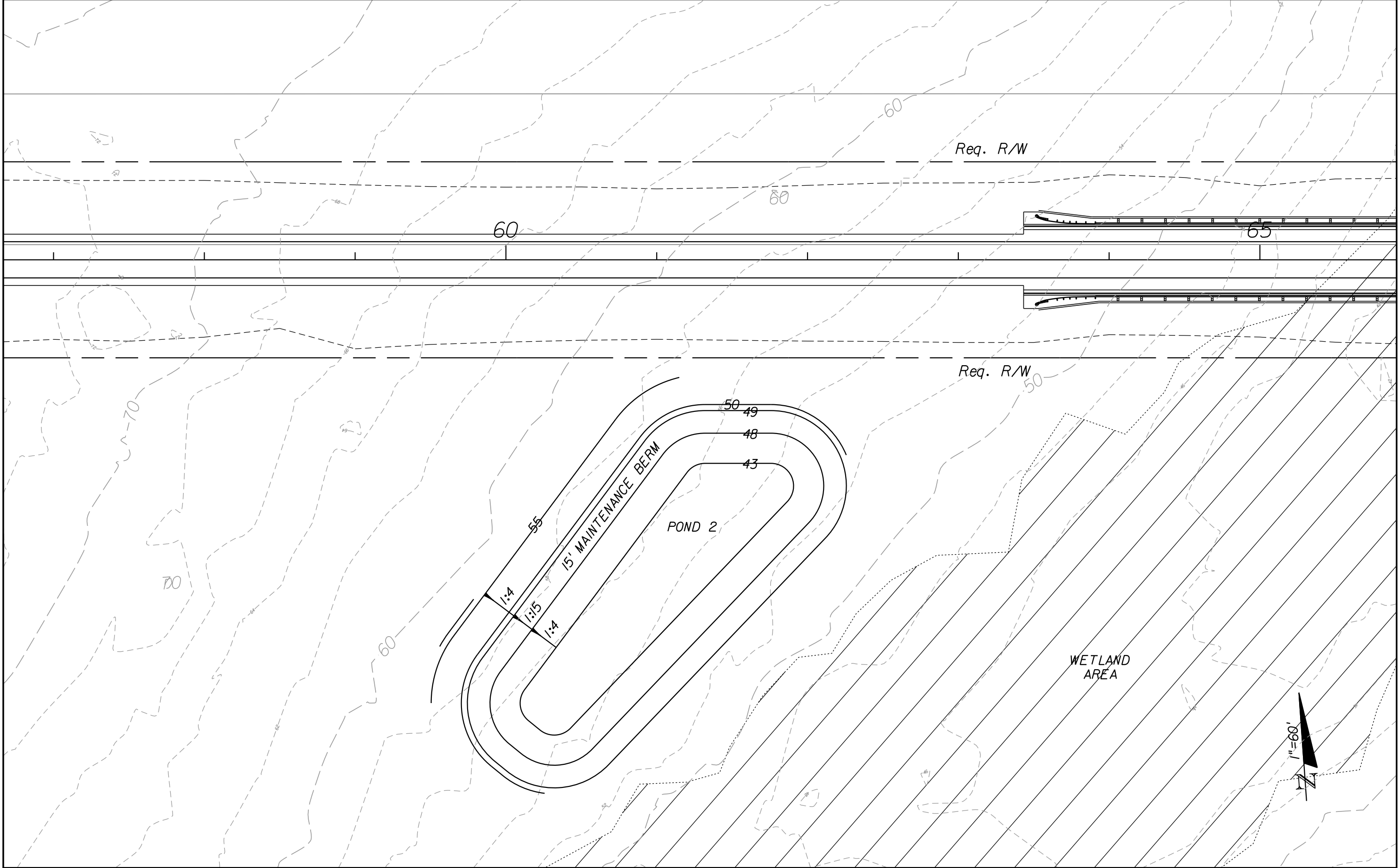

| REVISIONS |             |      |             |
|-----------|-------------|------|-------------|
| DATE      | DESCRIPTION | DATE | DESCRIPTION |
|           |             |      |             |



**Hatch Mott  
MacDonald**  
Post Office Box 2518 5111 North 12th Avenue  
Pensacola, Florida 32513 (850) 484-6011  
Engineer of Records: David D. Skipper, P.E. #58972



**Board of County Commissioners**  
Escambia County, Florida

|          |          |                      |
|----------|----------|----------------------|
| ROAD NO. | COUNTY   | FINANCIAL PROJECT ID |
|          | ESCAMBIA |                      |

*POND DETAIL*  
**POND 2**

|           |
|-----------|
| SHEET NO. |
|           |

NOTICE: THE OFFICIAL RECORD OF THIS SHEET IS THE ELECTRONIC FILE SIGNED AND SEALED UNDER RULE 61G15-23.003, F.A.C.

# Escambia County

Req. R/W

PC STA. 79+79.57

Req. R/W

15' MAINTENANCE BERM

POND 3

# Escambia County

WETLAND AREA



| REVISIONS |             |      |             |
|-----------|-------------|------|-------------|
| DATE      | DESCRIPTION | DATE | DESCRIPTION |
|           |             |      |             |



**Hatch Mott MacDonald**  
 Post Office Box 2518 5111 North 12th Avenue  
 Pensacola, Florida 32513 (850) 484-6011  
 Engineer of Records: David D. Skipper, P.E. \*58972



| Board of County Commissioners |          |                      |
|-------------------------------|----------|----------------------|
| Escambia County, Florida      |          |                      |
| ROAD NO.                      | COUNTY   | FINANCIAL PROJECT ID |
|                               | ESCAMBIA |                      |

*POND DETAIL*  
*POND 3*

SHEET NO.

NOTICE: THE OFFICIAL RECORD OF THIS SHEET IS THE ELECTRONIC FILE SIGNED AND SEALED UNDER RULE 61G15-23.003, F.A.C.

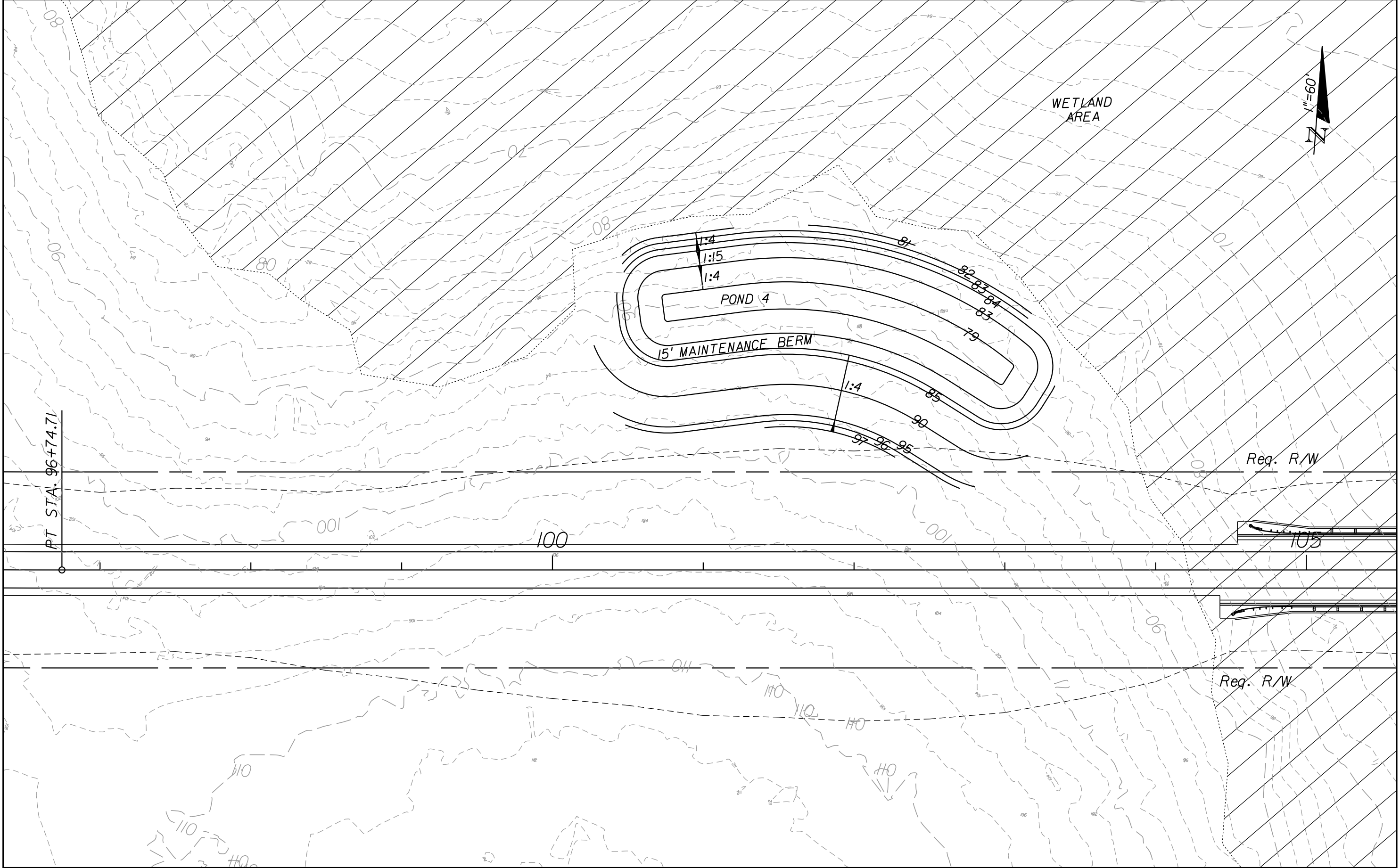

NOTICE: THE OFFICIAL RECORD OF THIS SHEET IS THE ELECTRONIC FILE SIGNED AND SEALED UNDER RULE 61G15-23.003, F.A.C.

| REVISIONS |             |      |             |
|-----------|-------------|------|-------------|
| DATE      | DESCRIPTION | DATE | DESCRIPTION |
|           |             |      |             |

**Hatch Mott MacDonald**  
 Post Office Box 2518 5111 North 12th Avenue  
 Pensacola, Florida 32513 (850) 484-6011  
 Engineer of Records: David D. Skipper, P.E. \*58972



|  |          |                      |
|--|----------|----------------------|
| <b>Board of County Commissioners</b><br>Escambia County, Florida |          |                      |
| ROAD NO.   | COUNTY   | FINANCIAL PROJECT ID |
|  | ESCAMBIA |                      |

**POND DETAIL**  
**POND 4**

|           |
|-----------|
| SHEET NO. |
|           |



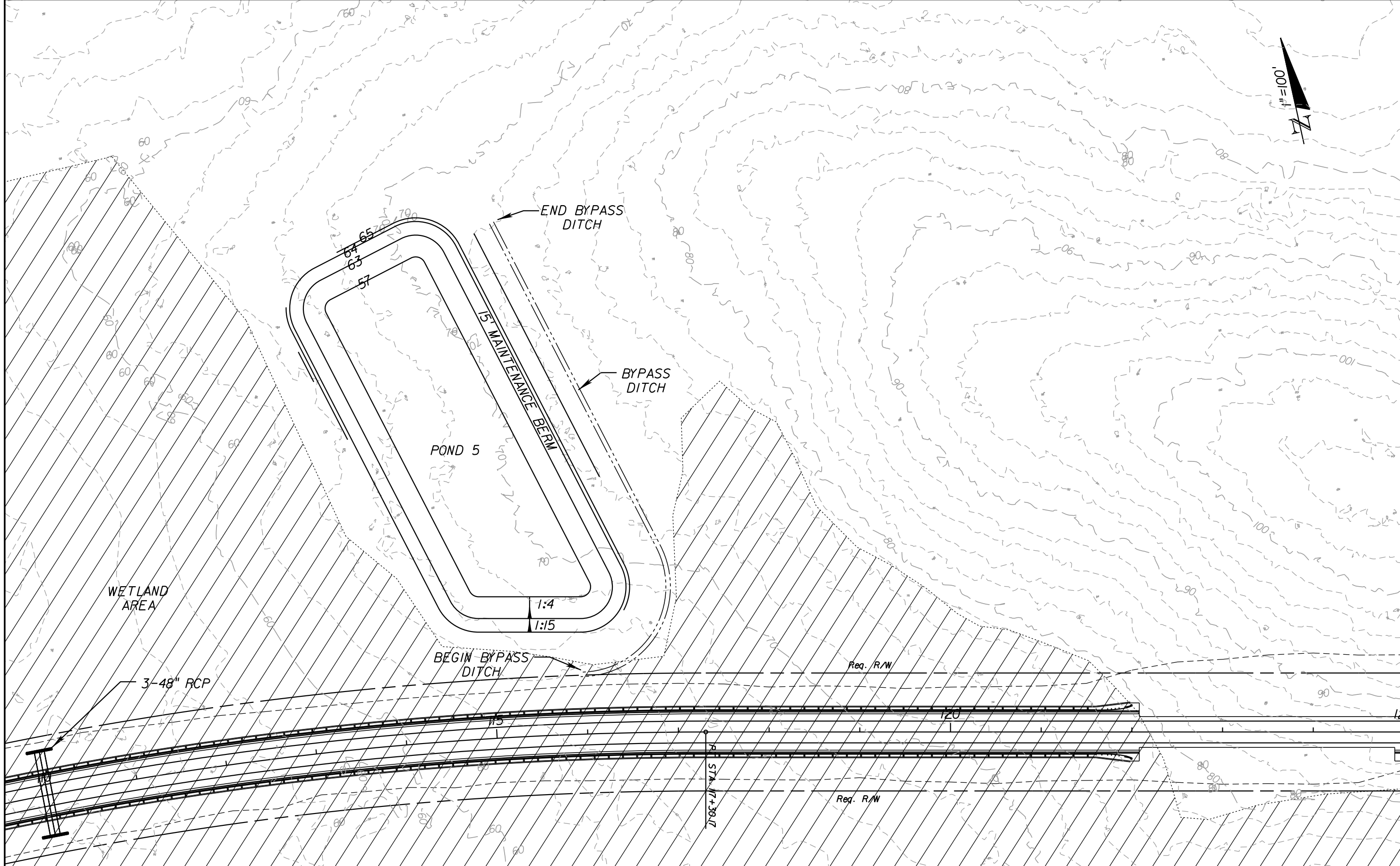

NOTICE: THE OFFICIAL RECORD OF THIS SHEET IS THE ELECTRONIC FILE SIGNED AND SEALED UNDER RULE 61G15-23.003, F.A.C.

| REVISIONS |             |      |             |
|-----------|-------------|------|-------------|
| DATE      | DESCRIPTION | DATE | DESCRIPTION |
|           |             |      |             |



**Hatch Mott  
MacDonald**  
Post Office Box 2518 5111 North 12th Avenue  
Pensacola, Florida 32513 (850) 484-6011  
Engineer of Record: David D. Skipper, P.E. \*58972



**Board of County Commissioners**  
Escambia County, Florida

|          |          |                      |
|----------|----------|----------------------|
| ROAD NO. | COUNTY   | FINANCIAL PROJECT ID |
|          | ESCAMBIA |                      |

*POND DETAIL*  
**POND 5**

SHEET NO.

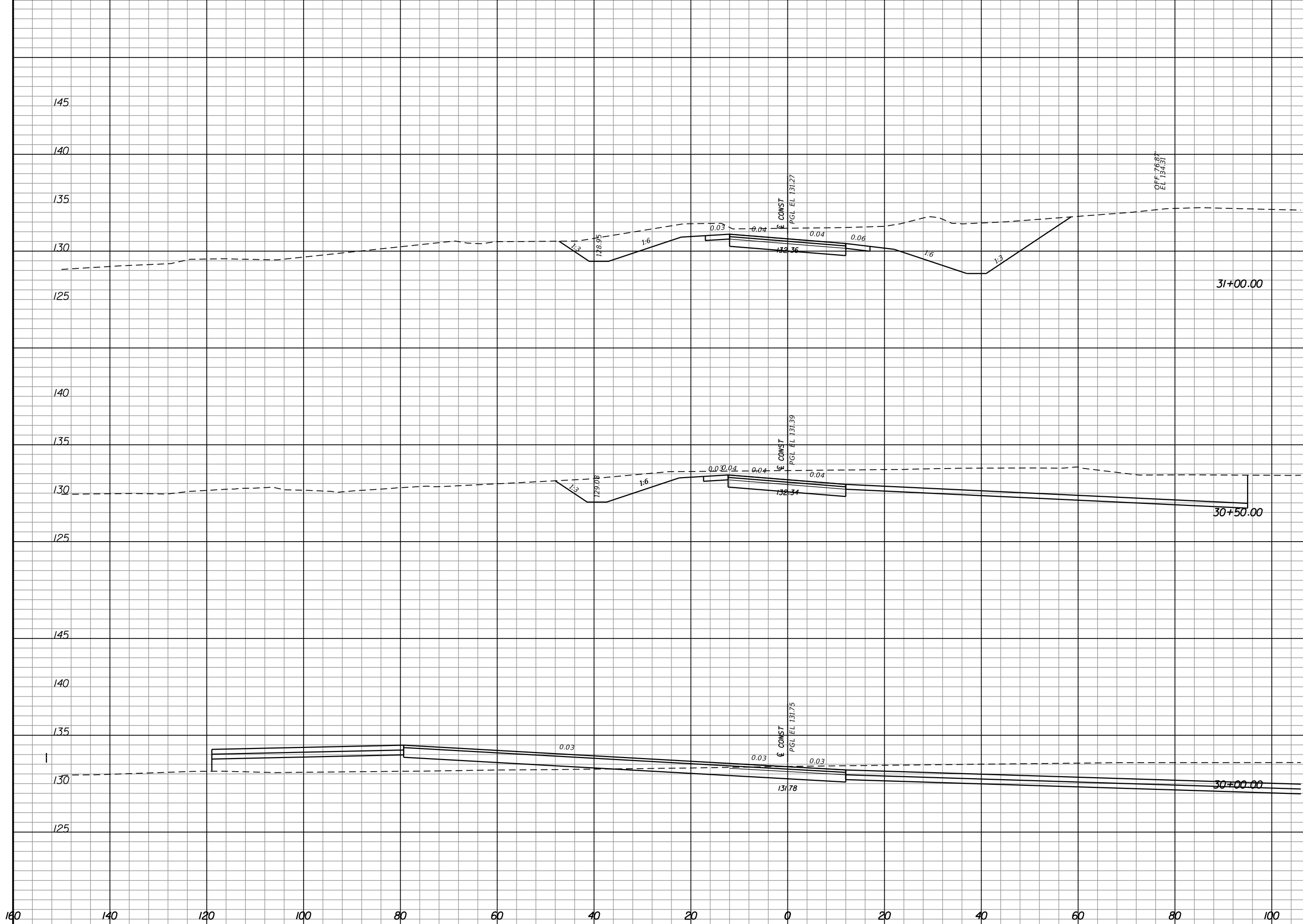

| Regular |     | Exc. |   | Embankment |    |
|---------|-----|------|---|------------|----|
| A       | V   | A    | V | A          | V  |
| 269.3   |     | 0.0  |   |            |    |
| 343.1   | 567 | 0.0  |   |            | 0  |
| 353.4   | 645 | 91.7 |   |            | 85 |
|         | 0   |      |   |            | 0  |

| REVISIONS |             |      |             |
|-----------|-------------|------|-------------|
| DATE      | DESCRIPTION | DATE | DESCRIPTION |
|           |             |      |             |

**Hatch Mott MacDonald**  
 Post Office Box 2518 Pensacola, Florida 32513  
 (850) 484-6011 - Certificate of Authorization #00000155  
 Engineer of Record: David D. Skipper, P.E. #58972

|  |          |                      |
|--|----------|----------------------|
| STATE OF FLORIDA<br>DEPARTMENT OF TRANSPORTATION |          |                      |
| ROAD NO.   | COUNTY   | FINANCIAL PROJECT ID |
|  | ESCAMBIA | 430002-1-52-01       |

**CROSS SECTIONS**

SHEET NO.

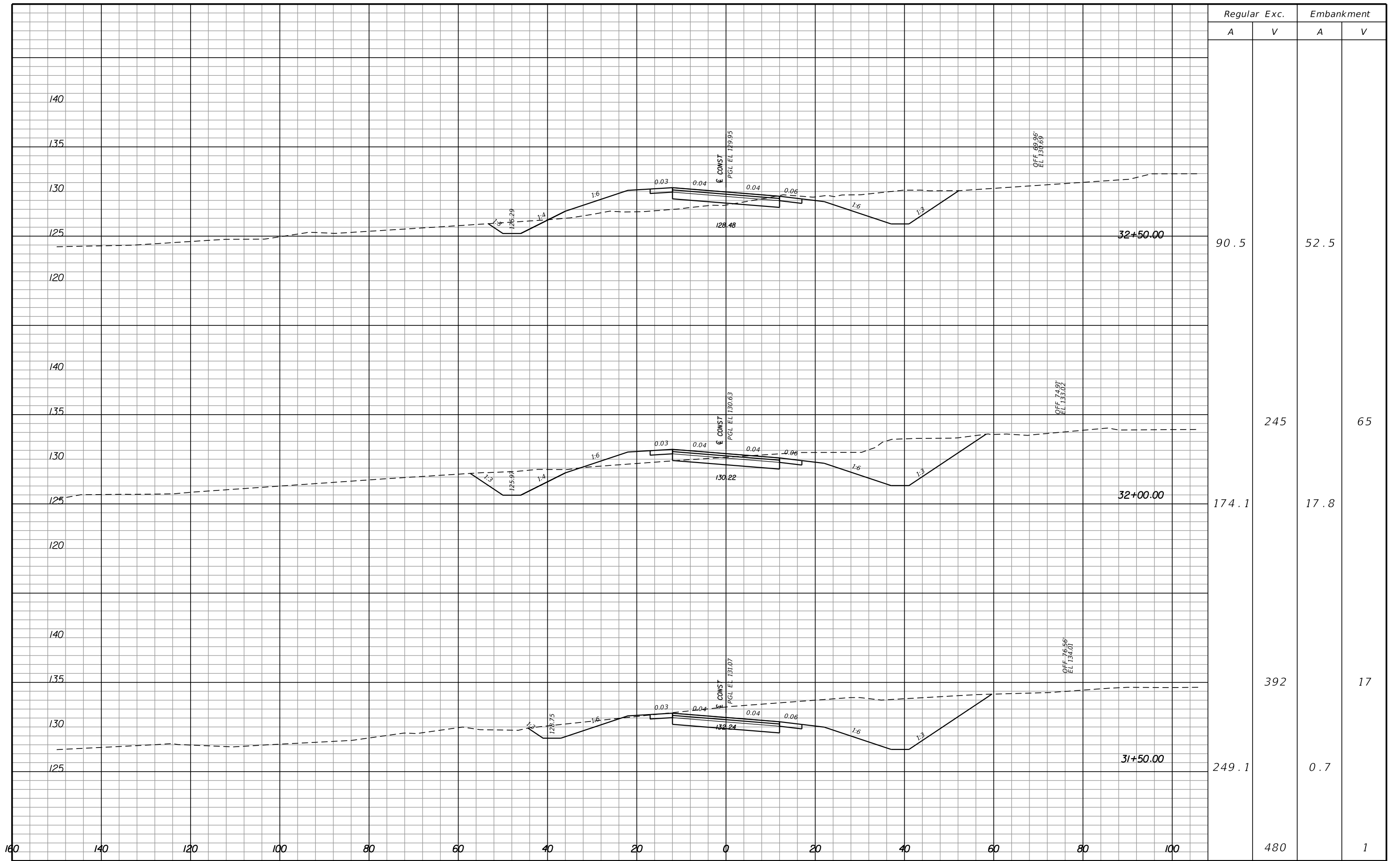

| REVISIONS |             |      |             |
|-----------|-------------|------|-------------|
| DATE      | DESCRIPTION | DATE | DESCRIPTION |
|           |             |      |             |

**Hatch Mott MacDonald**  
 Post Office Box 2518 Pensacola, Florida 32513  
 (850) 484-6011 - Certificate of Authorization #00000155  
 Engineer of Record: David D. Skipper, P.E. #58972

|  |          |                      |
|--|----------|----------------------|
| STATE OF FLORIDA<br>DEPARTMENT OF TRANSPORTATION |          |                      |
| ROAD NO.   | COUNTY   | FINANCIAL PROJECT ID |
|  | ESCAMBIA | 430002-1-52-01       |

CROSS SECTIONS

SHEET NO.

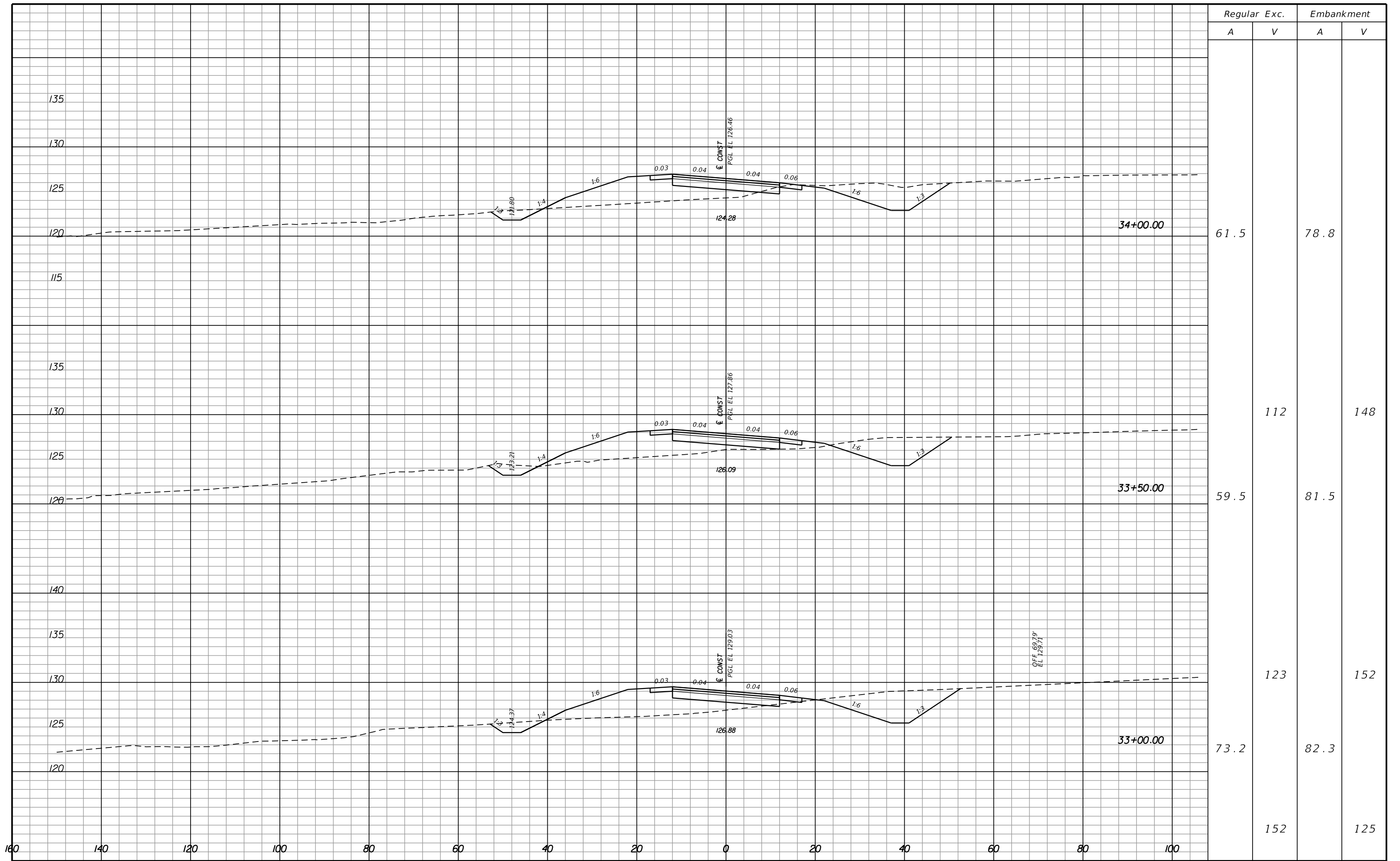

| REVISIONS |             |      |             |
|-----------|-------------|------|-------------|
| DATE      | DESCRIPTION | DATE | DESCRIPTION |
|           |             |      |             |

**Hatch Mott MacDonald**  
 Post Office Box 2518 Pensacola, Florida 32513  
 (850) 484-6011 - Certificate of Authorization #00000155  
 Engineer of Record: David D. Skipper, P.E. #58972

|  |          |                      |
|--|----------|----------------------|
| STATE OF FLORIDA<br>DEPARTMENT OF TRANSPORTATION |          |                      |
| ROAD NO.   | COUNTY   | FINANCIAL PROJECT ID |
|  | ESCAMBIA | 430002-1-52-01       |

**CROSS SECTIONS**

SHEET NO.

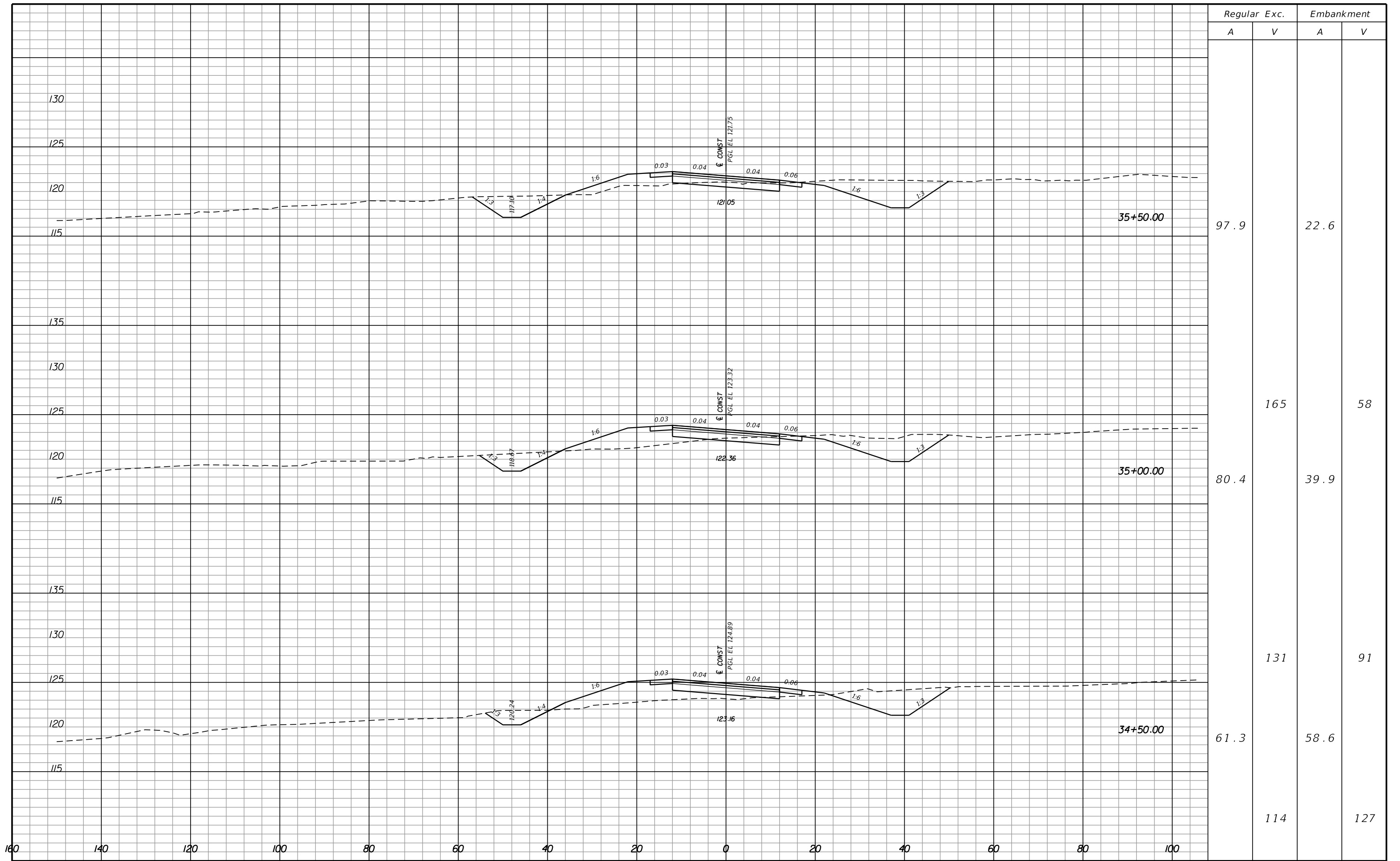

| REVISIONS |             |      |             |
|-----------|-------------|------|-------------|
| DATE      | DESCRIPTION | DATE | DESCRIPTION |
|           |             |      |             |

**Hatch Mott MacDonald**  
 Post Office Box 2518 Pensacola, Florida 32513  
 (850) 484-6011 - Certificate of Authorization #00000155  
 Engineer of Record: David D. Skipper, P.E. #58972

| STATE OF FLORIDA<br>DEPARTMENT OF TRANSPORTATION |          |                      |
|--|----------|----------------------|
| ROAD NO.   | COUNTY   | FINANCIAL PROJECT ID |
|  | ESCAMBIA | 430002-1-52-01       |

CROSS SECTIONS

|           |
|-----------|
| SHEET NO. |
|-----------|

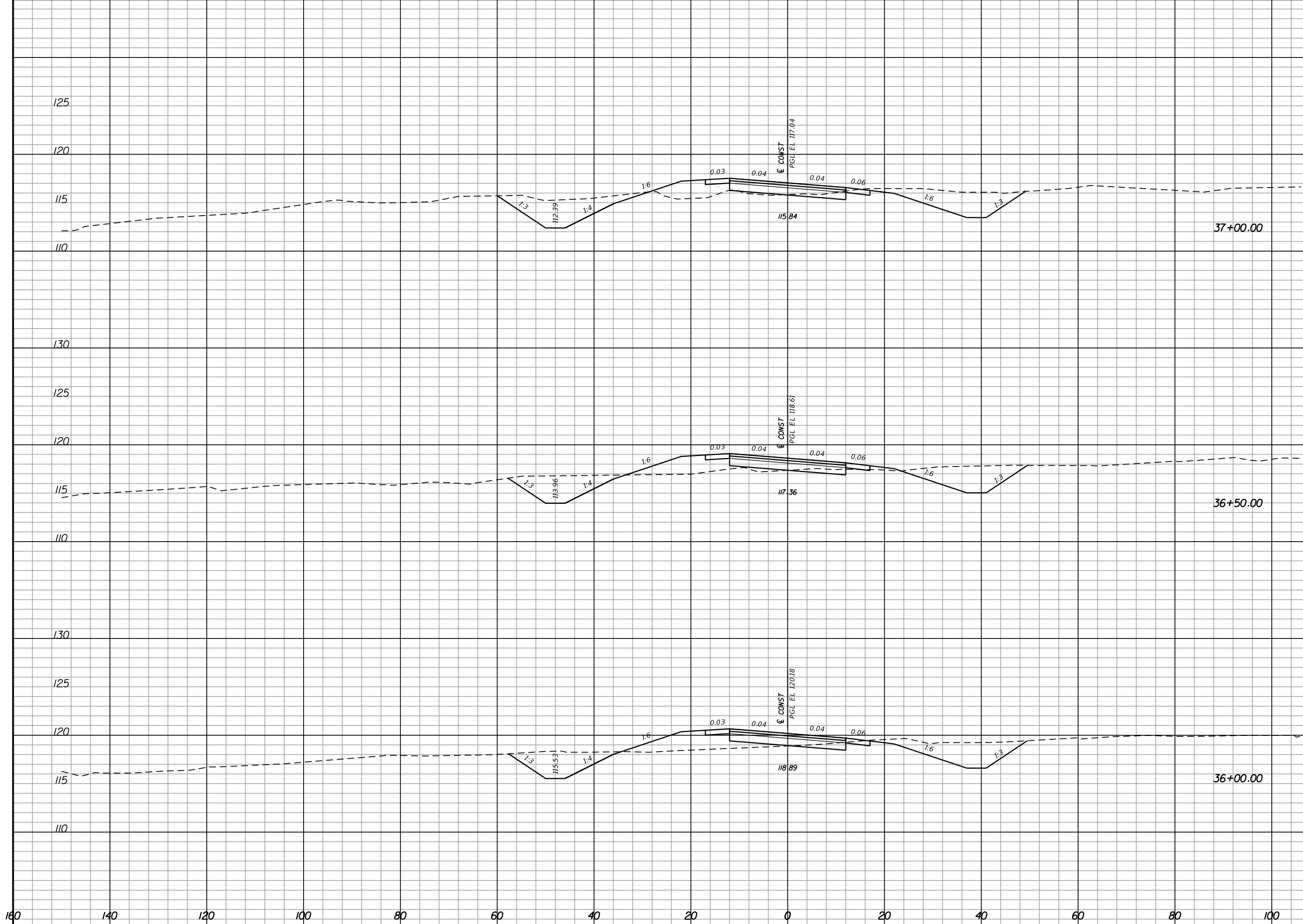

| Regular Exc. |      | Embankment |    |
|--------------|------|------------|----|
| A            | V    | A          | V  |
| 101.9        | 22.0 |            |    |
| 86.5         | 174  | 30.2       | 48 |
| 88.5         | 162  | 34.9       | 60 |
|              | 173  |            | 53 |

| REVISIONS |             |      |             |
|-----------|-------------|------|-------------|
| DATE      | DESCRIPTION | DATE | DESCRIPTION |
|           |             |      |             |

**Hatch Mott MacDonald**  
 Post Office Box 2518 Pensacola, Florida 32513  
 (850) 484-6011 - Certificate of Authorization #00000155  
 Engineer of Record: David D. Skipper, P.E. #58972

|  |          |                      |
|--|----------|----------------------|
| STATE OF FLORIDA<br>DEPARTMENT OF TRANSPORTATION |          |                      |
| ROAD NO.   | COUNTY   | FINANCIAL PROJECT ID |
|  | ESCAMBIA | 430002-1-52-01       |

**CROSS SECTIONS**

SHEET NO.

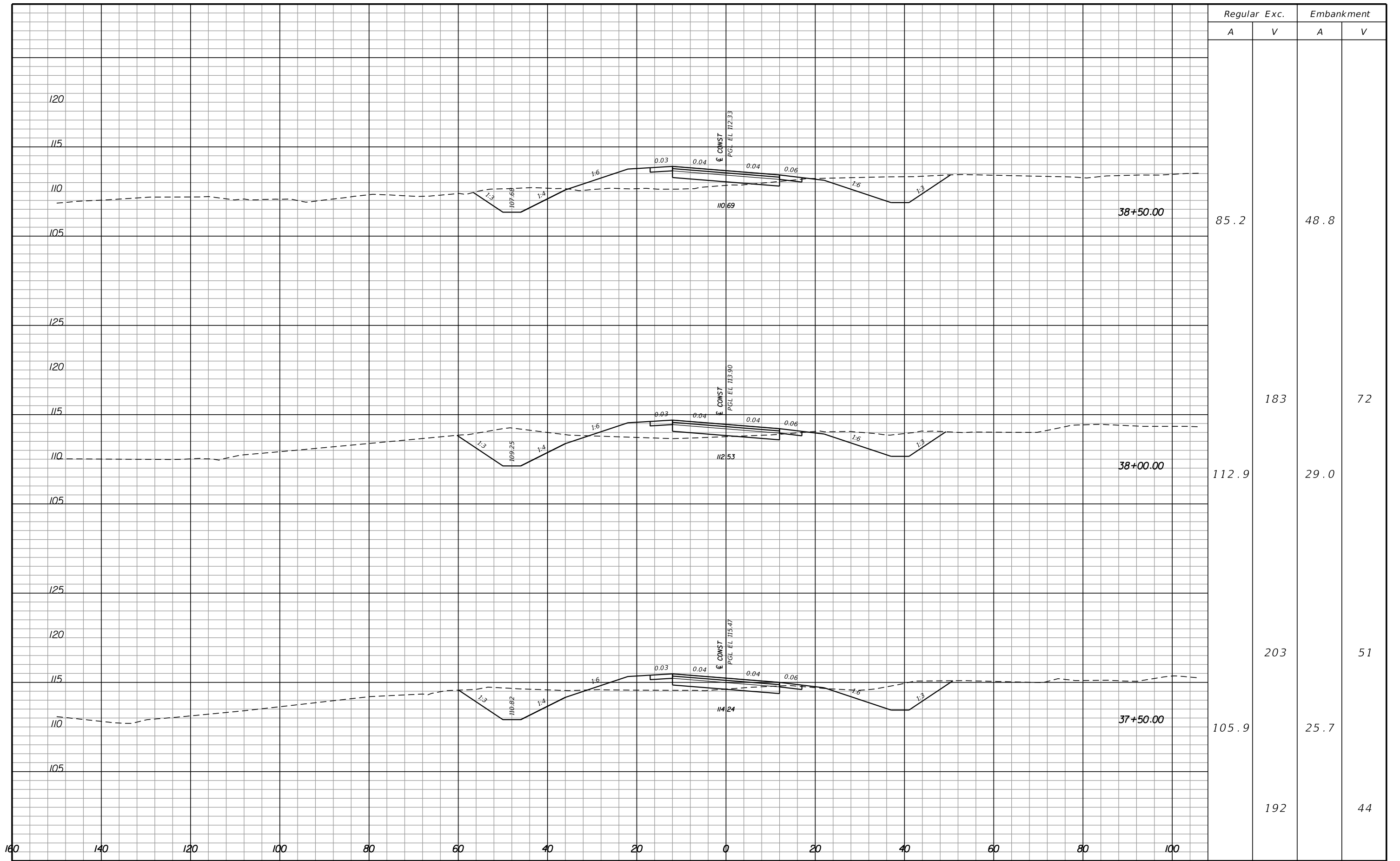

| Regular Exc. |     | Embankment |    |
|--------------|-----|------------|----|
| A            | V   | A          | V  |
| 85.2         |     | 48.8       |    |
| 112.9        | 183 | 29.0       | 72 |
| 105.9        | 203 | 25.7       | 51 |
|              | 192 |            | 44 |

| REVISIONS |             |      |             |
|-----------|-------------|------|-------------|
| DATE      | DESCRIPTION | DATE | DESCRIPTION |
|           |             |      |             |

**Hatch Mott MacDonald**  
 Post Office Box 2518 Pensacola, Florida 32513  
 (850) 484-6011 - Certificate of Authorization #00000155  
 Engineer of Record: David D. Skipper, P.E. #58972

|  |          |                      |
|--|----------|----------------------|
| STATE OF FLORIDA<br>DEPARTMENT OF TRANSPORTATION |          |                      |
| ROAD NO.   | COUNTY   | FINANCIAL PROJECT ID |
|  | ESCAMBIA | 430002-1-52-01       |

**CROSS SECTIONS**

SHEET NO.

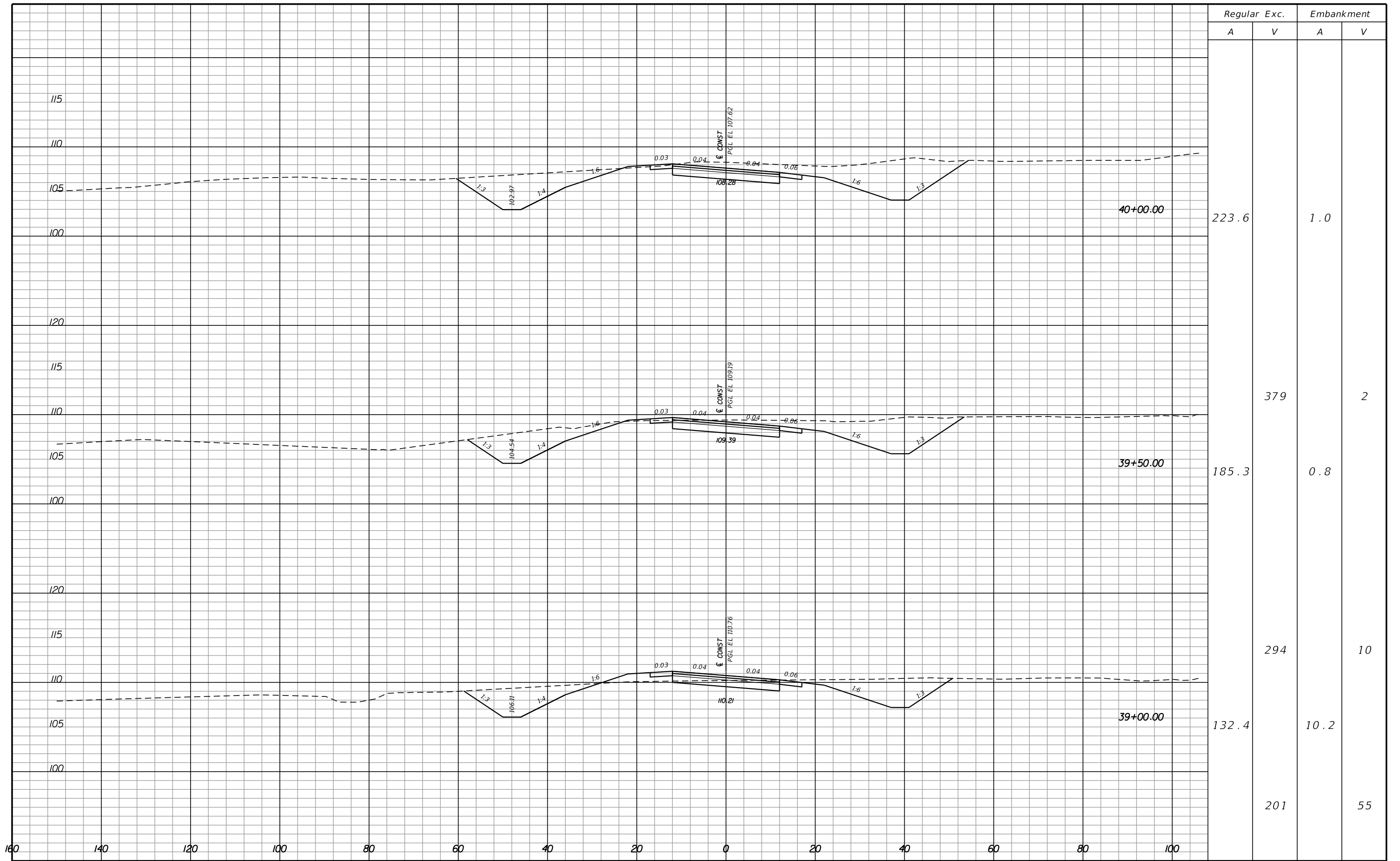

| REVISIONS |             |      |             |
|-----------|-------------|------|-------------|
| DATE      | DESCRIPTION | DATE | DESCRIPTION |
|           |             |      |             |

**Hatch Mott MacDonald**  
 Post Office Box 2518 Pensacola, Florida 32513  
 (850) 484-6011 - Certificate of Authorization #00000155  
 Engineer of Record: David D. Skipper, P.E. #58972

|  |          |                      |
|--|----------|----------------------|
| STATE OF FLORIDA<br>DEPARTMENT OF TRANSPORTATION |          |                      |
| ROAD NO.   | COUNTY   | FINANCIAL PROJECT ID |
|  | ESCAMBIA | 430002-1-52-01       |

CROSS SECTIONS

SHEET NO.



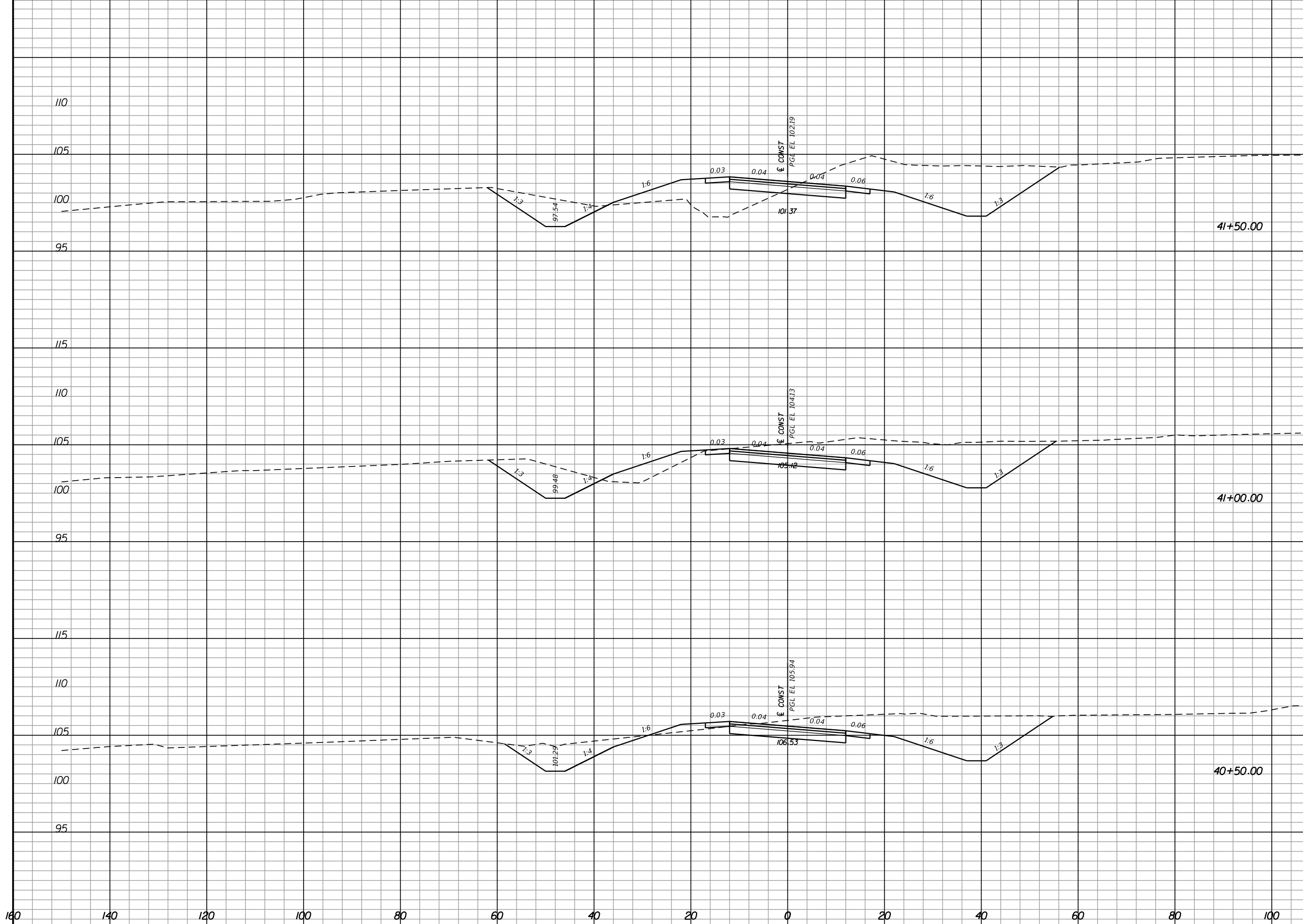

| Regular |     | Exc. |      | Embankment |   |
|---------|-----|------|------|------------|---|
| A       | V   | A    | V    | A          | V |
| 219.5   |     |      | 62.4 |            |   |
| 231.7   | 418 | 23.9 |      | 80         |   |
| 211.4   | 410 | 6.4  |      | 28         |   |
|         | 403 |      | 7    |            |   |

| REVISIONS |             |      |             |
|-----------|-------------|------|-------------|
| DATE      | DESCRIPTION | DATE | DESCRIPTION |
|           |             |      |             |

**Hatch Mott MacDonald**  
 Post Office Box 2518 Pensacola, Florida 32513  
 (850) 484-6011 - Certificate of Authorization #00000155  
 Engineer of Record: David D. Skipper, P.E. #58972

|  |          |                      |
|--|----------|----------------------|
| STATE OF FLORIDA<br>DEPARTMENT OF TRANSPORTATION |          |                      |
| ROAD NO.   | COUNTY   | FINANCIAL PROJECT ID |
|  | ESCAMBIA | 430002-1-52-01       |

**CROSS SECTIONS**

SHEET NO.

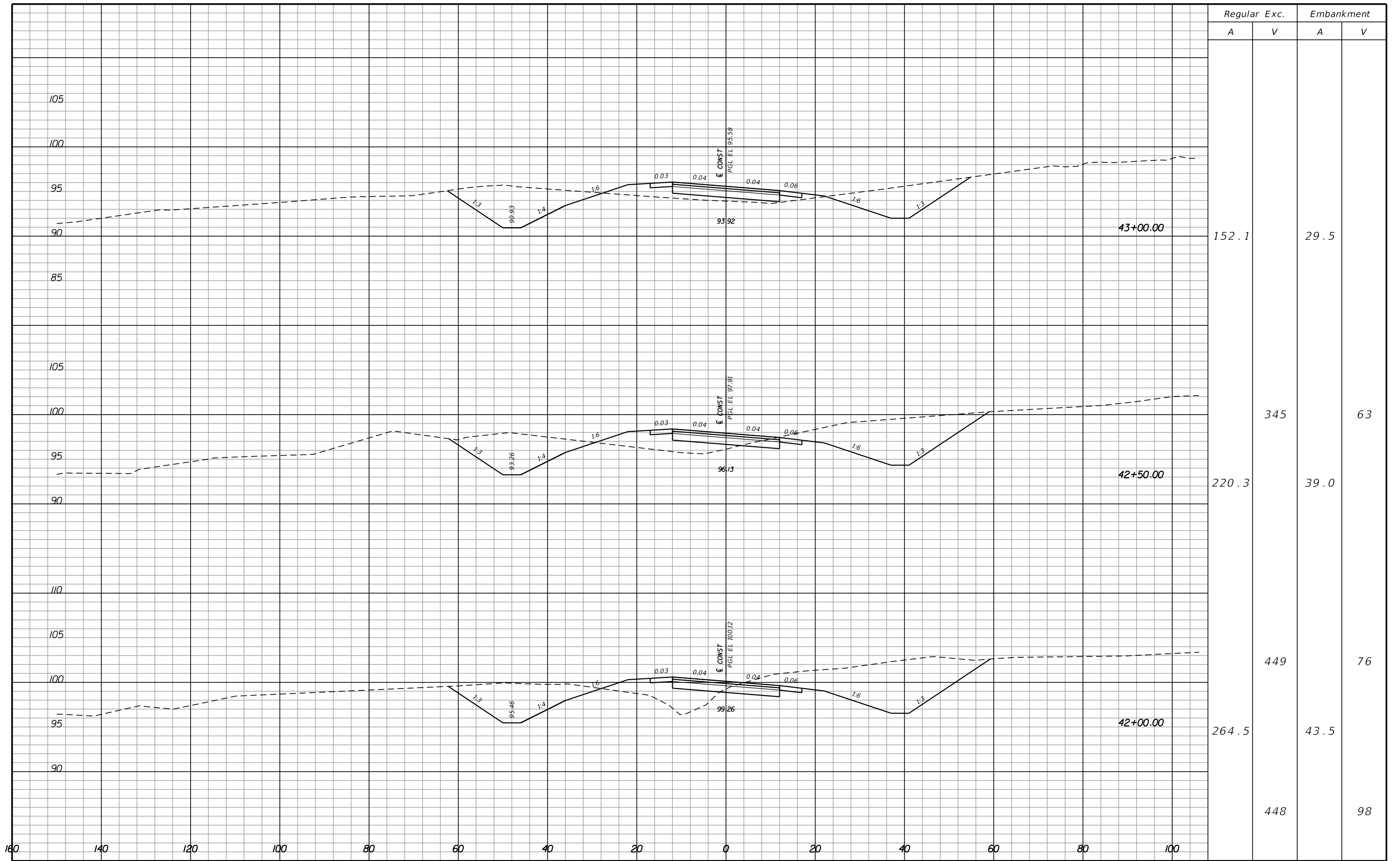

| REVISIONS |             |      |             |
|-----------|-------------|------|-------------|
| DATE      | DESCRIPTION | DATE | DESCRIPTION |
|           |             |      |             |



**Hatch Mott  
MacDonald**  
Post Office Box 2518 Pensacola, Florida 32513  
(850) 484-6011 - Certificate of Authorization #00000155  
Engineer of Record: David D. Skipper, P.E. #58972

|  |          |                      |
|--|----------|----------------------|
| STATE OF FLORIDA<br>DEPARTMENT OF TRANSPORTATION |          |                      |
| ROAD NO.   | COUNTY   | FINANCIAL PROJECT ID |
|  | ESCAMBIA | 430002-1-52-01       |

CROSS SECTIONS

|              |
|--------------|
| SHEET<br>NO. |
|              |

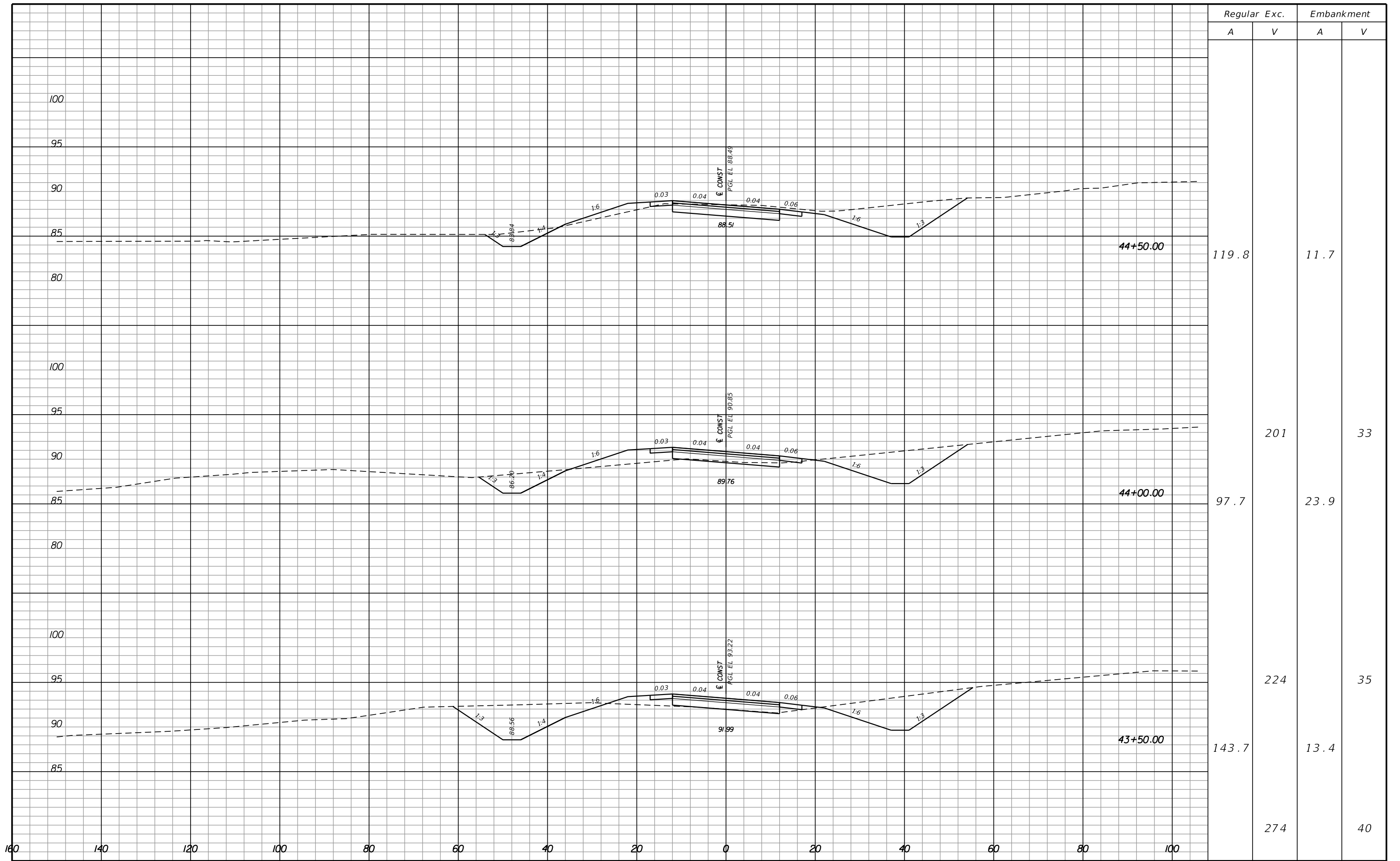

| REVISIONS |             |      |             |
|-----------|-------------|------|-------------|
| DATE      | DESCRIPTION | DATE | DESCRIPTION |
|           |             |      |             |



**Hatch Mott  
MacDonald**  
Post Office Box 2518 Pensacola, Florida 32513  
(850) 484-6011 - Certificate of Authorization #00000155  
Engineer of Record: David D. Skipper, P.E. #58972

|  |          |                      |
|--|----------|----------------------|
| STATE OF FLORIDA<br>DEPARTMENT OF TRANSPORTATION |          |                      |
| ROAD NO.   | COUNTY   | FINANCIAL PROJECT ID |
|  | ESCAMBIA | 430002-1-52-01       |

**CROSS SECTIONS**

|           |
|-----------|
| SHEET NO. |
|           |

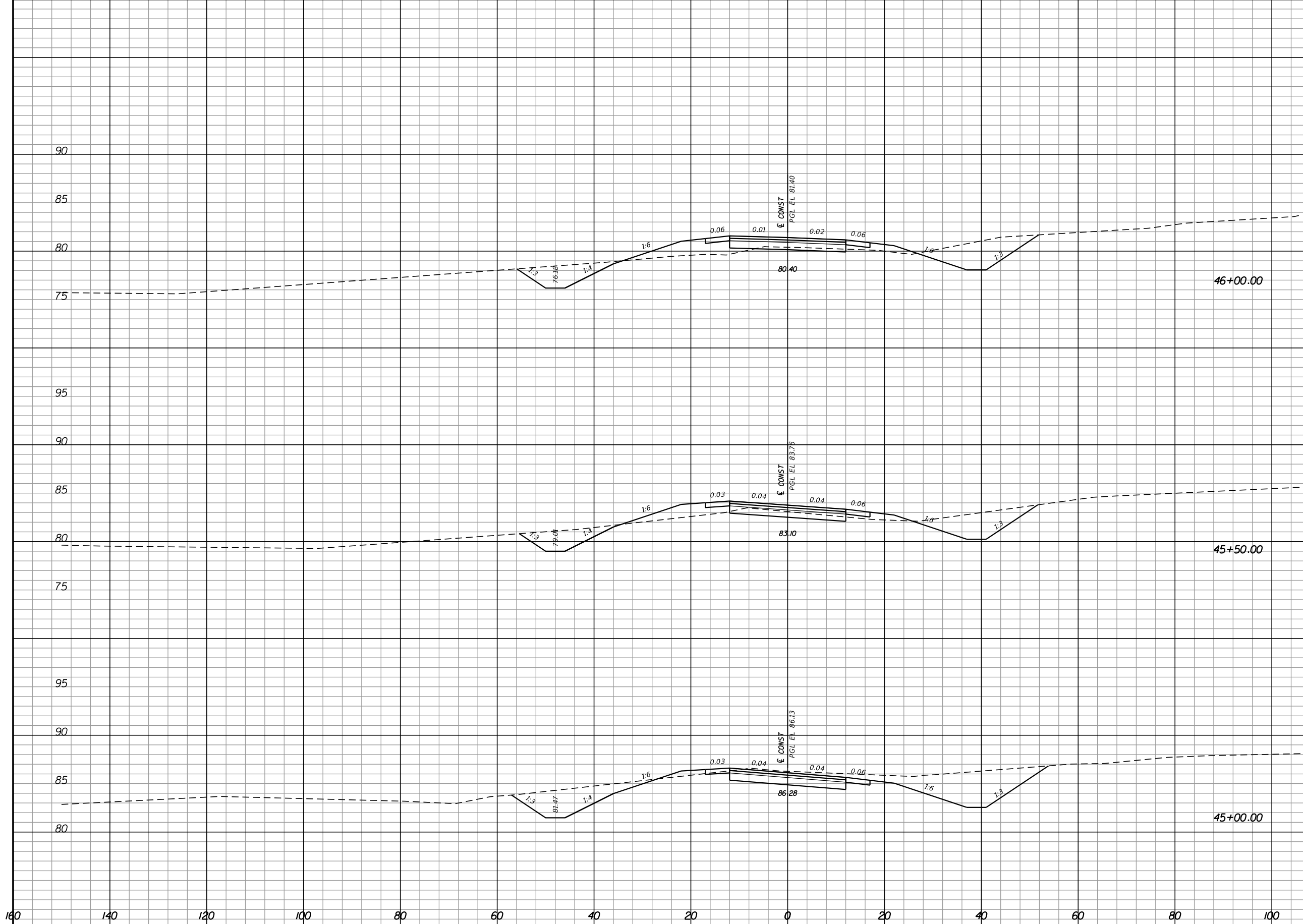

| Regular |     | Exc. |   | Embankment |    |
|---------|-----|------|---|------------|----|
| A       | V   | A    | V | A          | V  |
| 76.5    |     |      |   | 32.1       |    |
| 78.0    | 143 |      |   | 24.0       | 52 |
| 159.1   | 220 |      |   | 3.8        | 26 |
|         | 258 |      |   |            | 14 |

| REVISIONS |             |      |             |
|-----------|-------------|------|-------------|
| DATE      | DESCRIPTION | DATE | DESCRIPTION |
|           |             |      |             |

**Hatch Mott MacDonald**  
 Post Office Box 2518 Pensacola, Florida 32513  
 (850) 484-6011 - Certificate of Authorization #00000155  
 Engineer of Record: David D. Skipper, P.E. #58972

|  |          |                      |
|--|----------|----------------------|
| STATE OF FLORIDA<br>DEPARTMENT OF TRANSPORTATION |          |                      |
| ROAD NO.   | COUNTY   | FINANCIAL PROJECT ID |
|  | ESCAMBIA | 430002-1-52-01       |

**CROSS SECTIONS**

SHEET NO.

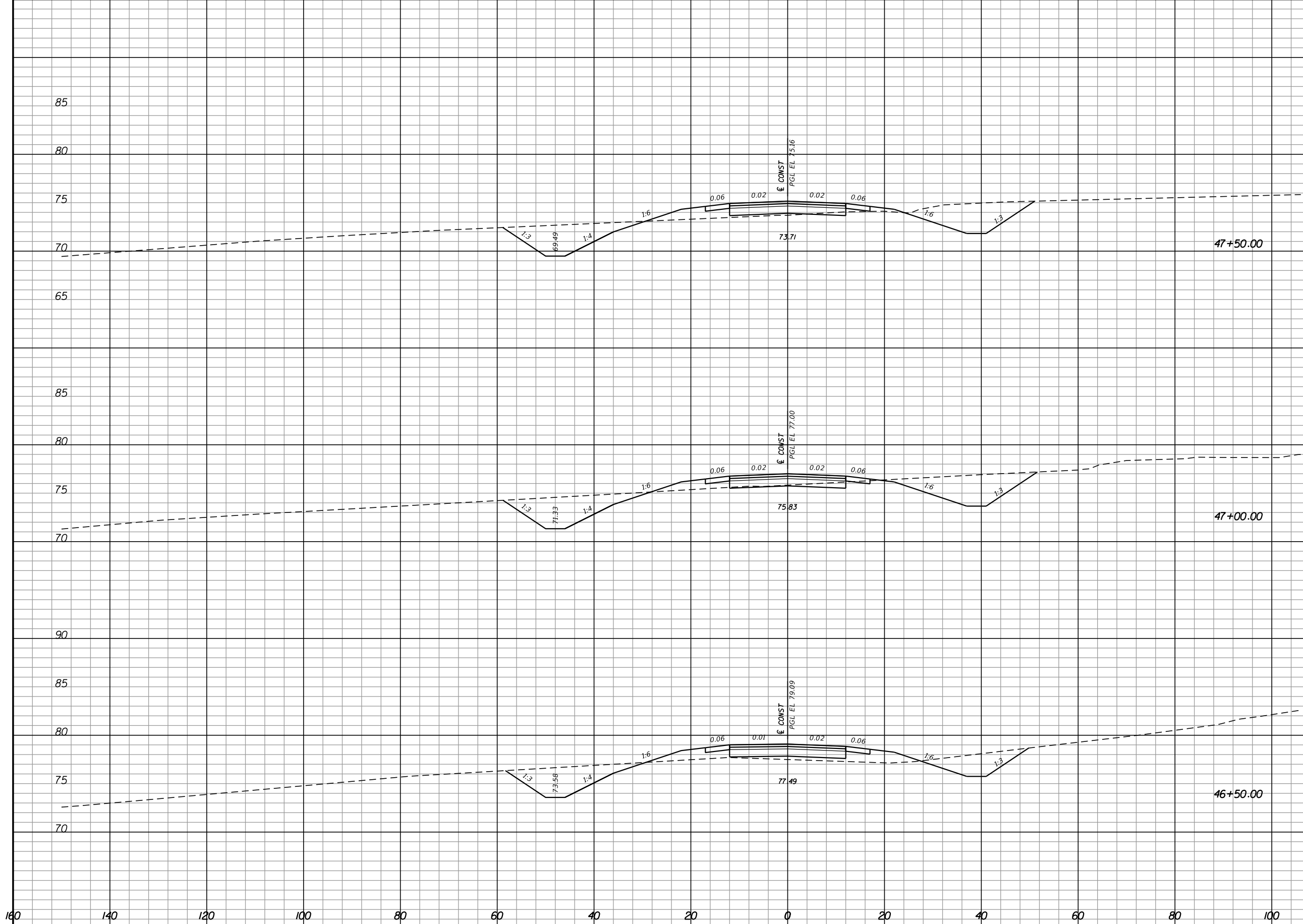

| Regular |     | Exc. |      | Embankment |   |
|---------|-----|------|------|------------|---|
| A       | V   | A    | V    | A          | V |
| 101.9   |     |      | 19.8 |            |   |
| 115.2   | 201 | 10.5 |      | 28         |   |
| 78.2    | 179 | 33.1 | 40   |            |   |
|         | 143 |      | 60   |            |   |

| REVISIONS |             |      |             |
|-----------|-------------|------|-------------|
| DATE      | DESCRIPTION | DATE | DESCRIPTION |
|           |             |      |             |

**Hatch Mott MacDonald**  
 Post Office Box 2518 Pensacola, Florida 32513  
 (850) 484-6011 - Certificate of Authorization #00000155  
 Engineer of Record: David D. Skipper, P.E. #58972

|  |          |                      |
|--|----------|----------------------|
| STATE OF FLORIDA<br>DEPARTMENT OF TRANSPORTATION |          |                      |
| ROAD NO.   | COUNTY   | FINANCIAL PROJECT ID |
|  | ESCAMBIA | 430002-1-52-01       |

**CROSS SECTIONS**

SHEET NO.

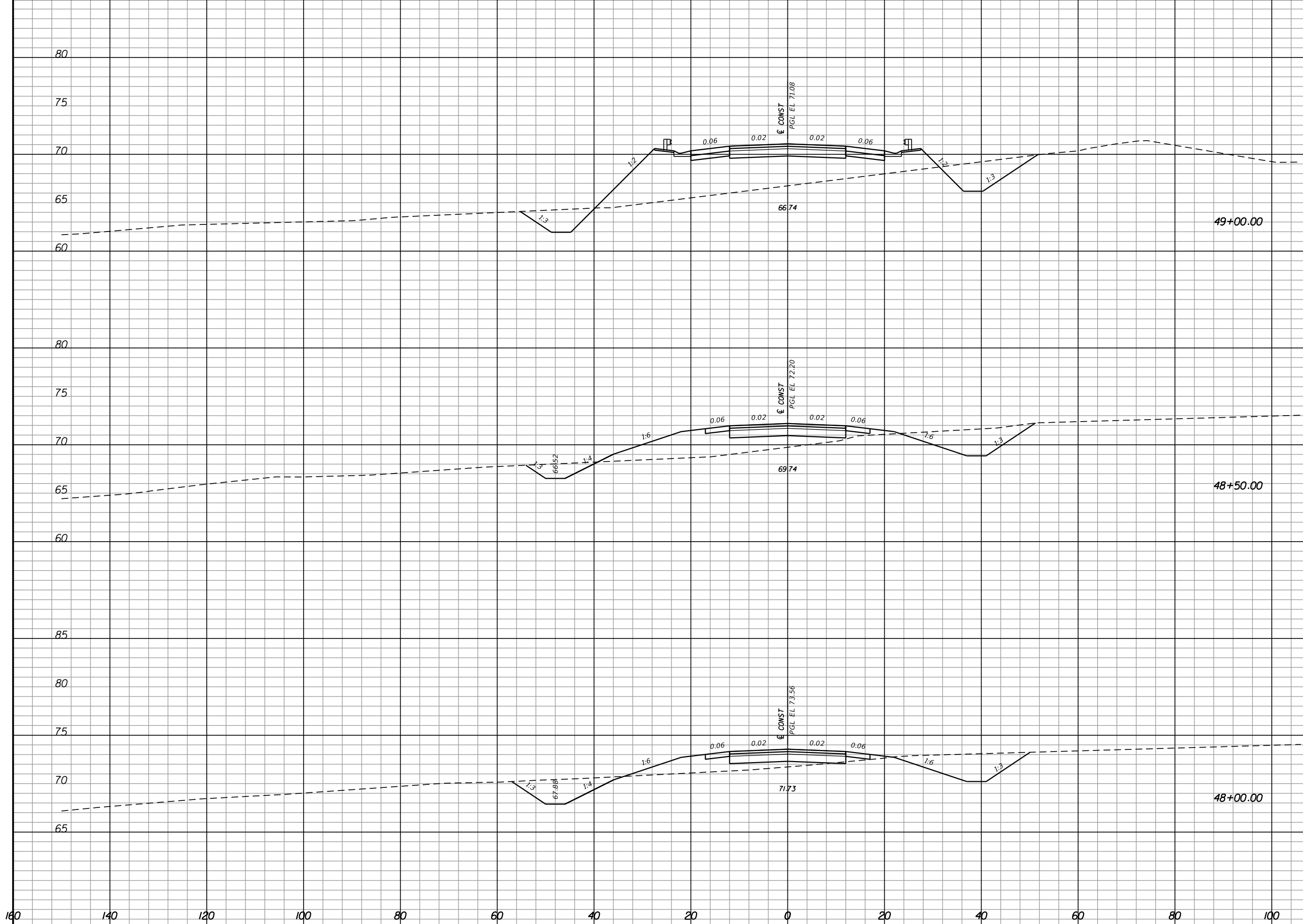

| Regular |     | Exc. |   | Embankment |   |
|---------|-----|------|---|------------|---|
| A       | V   | A    | V | A          | V |
| 58.7    |     |      |   | 205.8      |   |
| 57.9    | 108 | 82.5 |   | 267        |   |
| 80.5    | 128 | 39.4 |   | 113        |   |
|         | 169 |      |   | 55         |   |

| REVISIONS |             |      |             |
|-----------|-------------|------|-------------|
| DATE      | DESCRIPTION | DATE | DESCRIPTION |
|           |             |      |             |

**Hatch Mott MacDonald**  
 Post Office Box 2518 Pensacola, Florida 32513  
 (850) 484-6011 - Certificate of Authorization #00000155  
 Engineer of Record: David D. Skipper, P.E. #58972

|  |          |                      |
|--|----------|----------------------|
| STATE OF FLORIDA<br>DEPARTMENT OF TRANSPORTATION |          |                      |
| ROAD NO.   | COUNTY   | FINANCIAL PROJECT ID |
|  | ESCAMBIA | 430002-1-52-01       |

**CROSS SECTIONS**

SHEET NO.

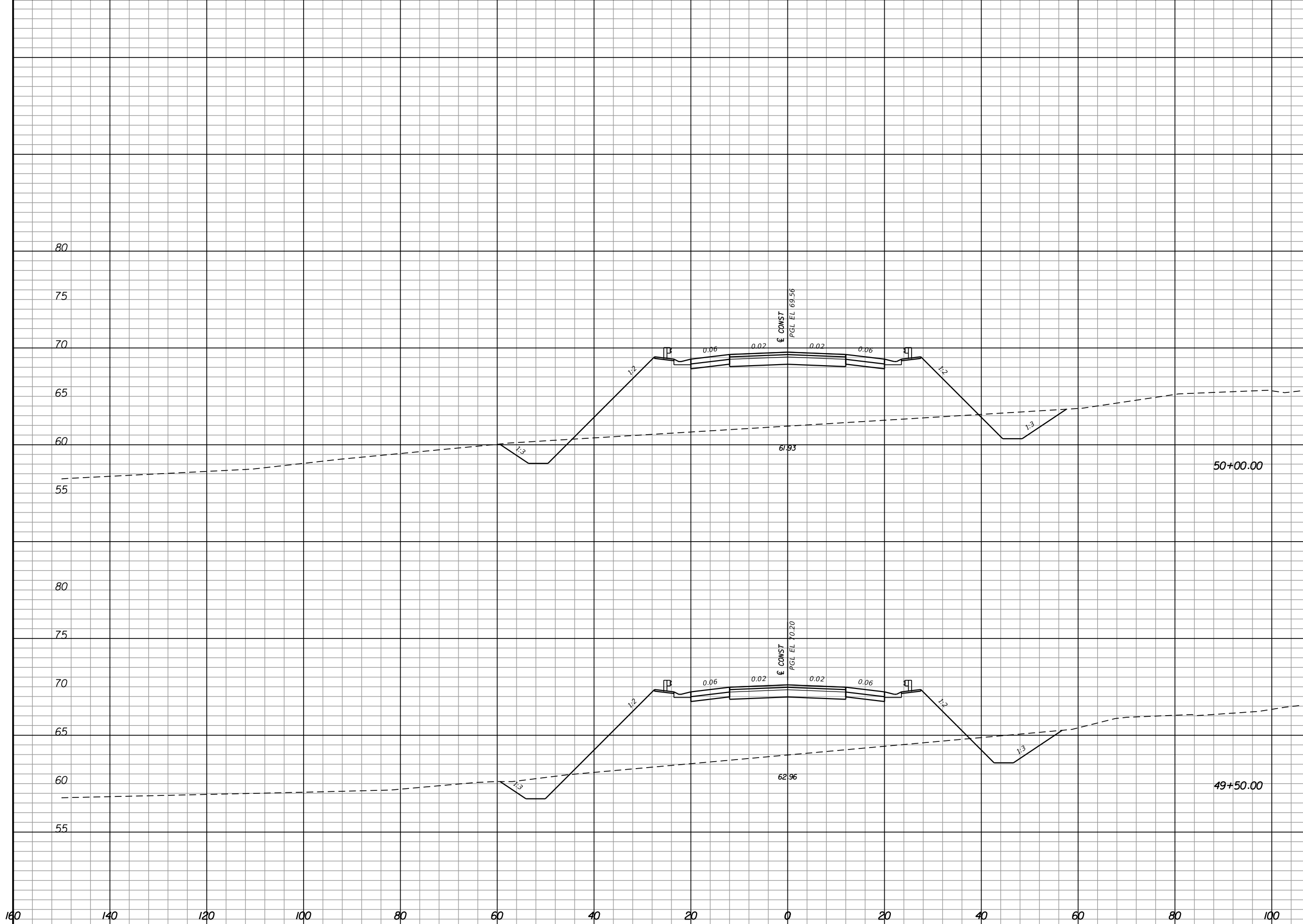

| Regular Exc. |     | Embankment |     |
|--------------|-----|------------|-----|
| A            | V   | A          | V   |
| 52.0         |     | 454.0      |     |
| 51.5         | 96  | 424.5      | 813 |
|              | 102 |            | 584 |

| REVISIONS |             |      |             |
|-----------|-------------|------|-------------|
| DATE      | DESCRIPTION | DATE | DESCRIPTION |
|           |             |      |             |

**Hatch Mott MacDonald**  
 Post Office Box 2518 Pensacola, Florida 32513  
 (850) 484-6011 - Certificate of Authorization #00000155  
 Engineer of Record: David D. Skipper, P.E. #58972

|  |          |                      |
|--|----------|----------------------|
| STATE OF FLORIDA<br>DEPARTMENT OF TRANSPORTATION |          |                      |
| ROAD NO.   | COUNTY   | FINANCIAL PROJECT ID |
|  | ESCAMBIA | 430002-1-52-01       |

**CROSS SECTIONS**

SHEET NO.

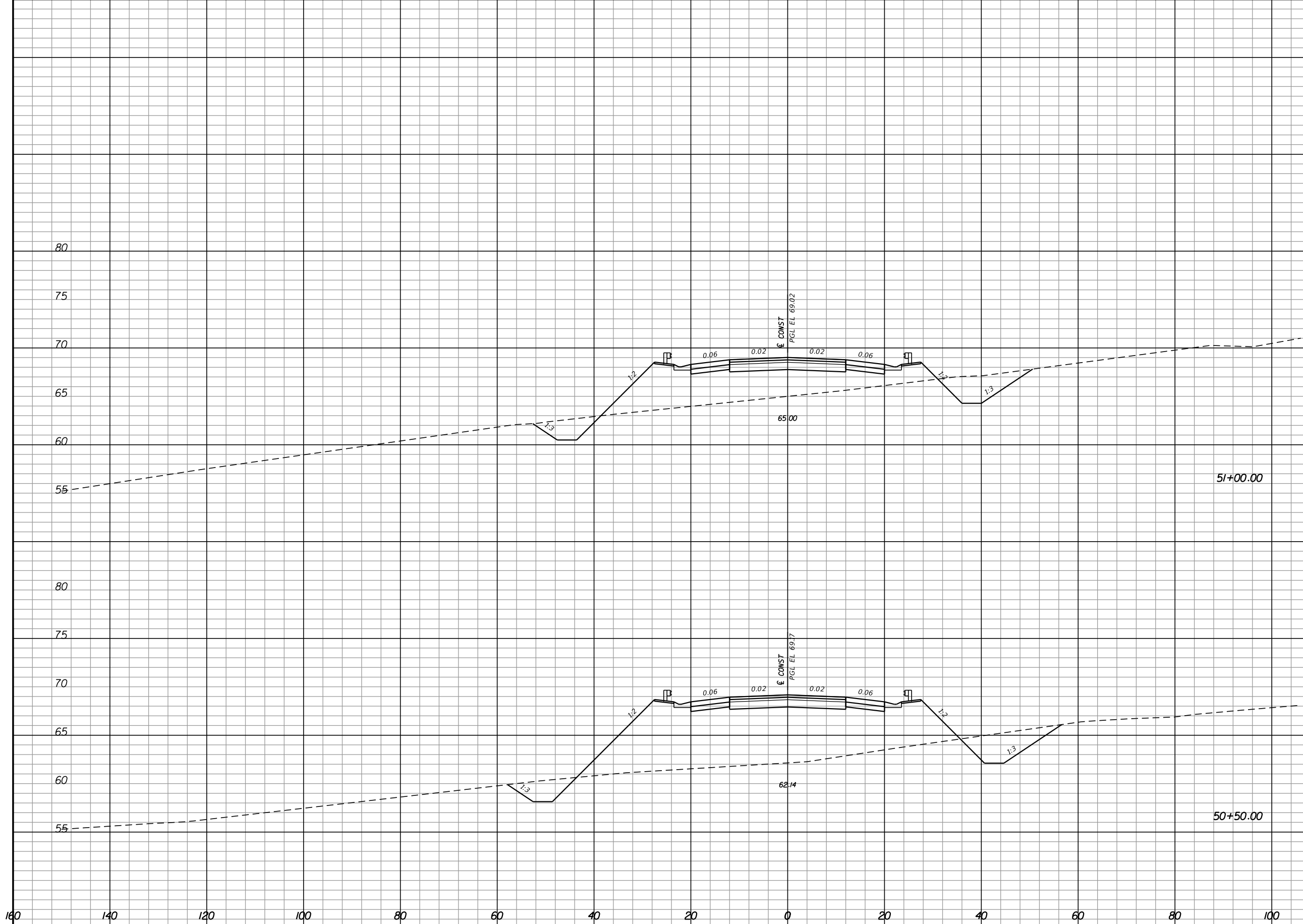

| Regular |     | Exc. |   | Embankment |     |
|---------|-----|------|---|------------|-----|
| A       | V   | A    | V | A          | V   |
| 52.2    |     |      |   | 178.8      |     |
| 57.7    | 102 |      |   | 380.0      | 517 |
|         | 102 |      |   |            | 772 |

| REVISIONS |             |      |             |
|-----------|-------------|------|-------------|
| DATE      | DESCRIPTION | DATE | DESCRIPTION |
|           |             |      |             |

**Hatch Mott MacDonald**  
 Post Office Box 2518 Pensacola, Florida 32513  
 (850) 484-6011 - Certificate of Authorization #00000155  
 Engineer of Record: David D. Skipper, P.E. #58972

|  |          |                      |
|--|----------|----------------------|
| STATE OF FLORIDA<br>DEPARTMENT OF TRANSPORTATION |          |                      |
| ROAD NO.   | COUNTY   | FINANCIAL PROJECT ID |
|  | ESCAMBIA | 430002-1-52-01       |

**CROSS SECTIONS**

|           |
|-----------|
| SHEET NO. |
|           |





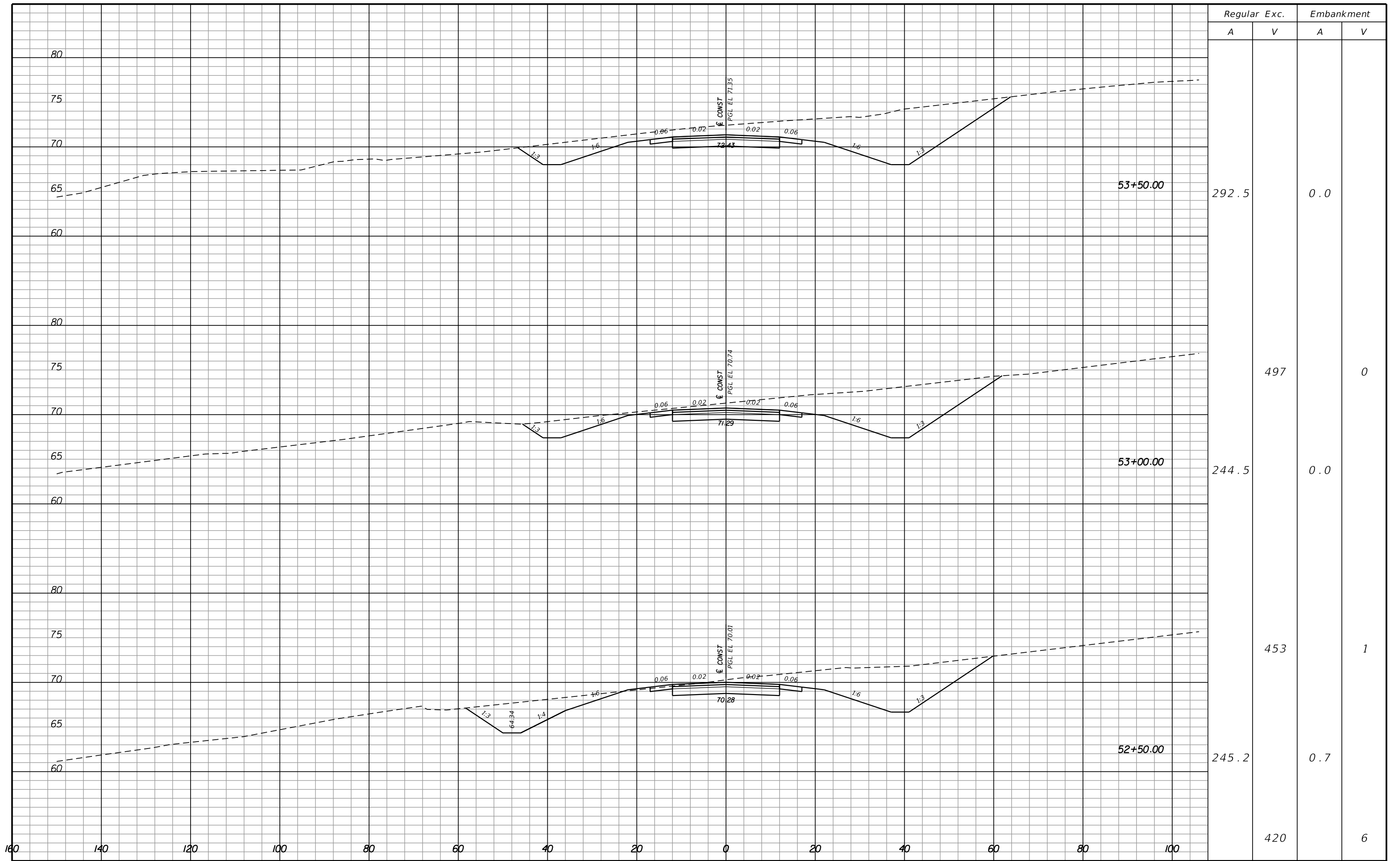

| REVISIONS |             |      |             |
|-----------|-------------|------|-------------|
| DATE      | DESCRIPTION | DATE | DESCRIPTION |
|           |             |      |             |

**Hatch Mott MacDonald**  
 Post Office Box 2518 Pensacola, Florida 32513  
 (850) 484-6011 - Certificate of Authorization #00000155  
 Engineer of Record: David D. Skipper, P.E. #58972

|  |          |                      |
|--|----------|----------------------|
| STATE OF FLORIDA<br>DEPARTMENT OF TRANSPORTATION |          |                      |
| ROAD NO.   | COUNTY   | FINANCIAL PROJECT ID |
|  | ESCAMBIA | 430002-1-52-01       |

CROSS SECTIONS

SHEET NO.

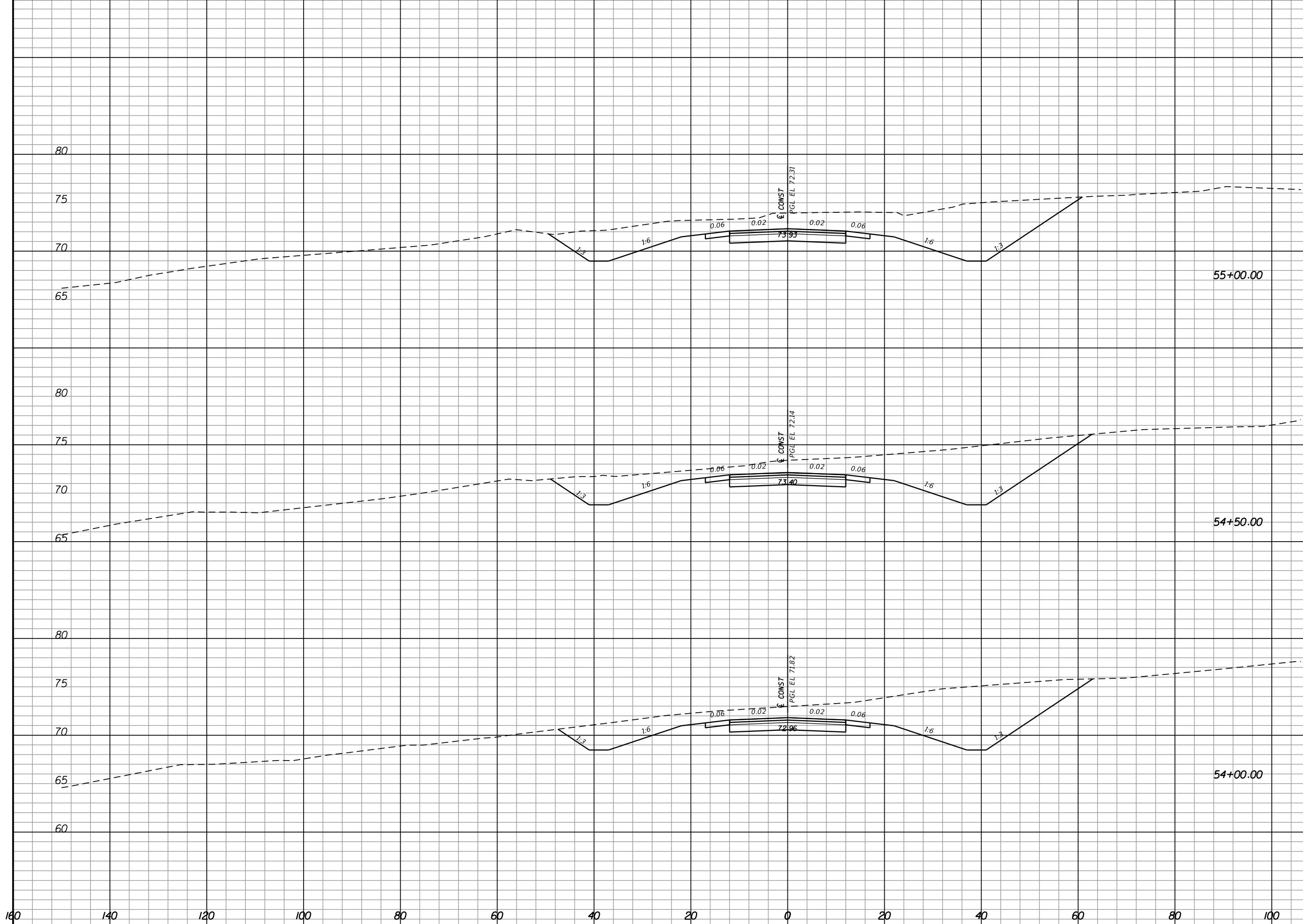

| Regular |     | Exc. |   | Embankment |   |
|---------|-----|------|---|------------|---|
| A       | V   | A    | V | A          | V |
| 317.2   |     |      |   | 0.0        |   |
| 307.1   | 578 |      |   | 0.0        | 0 |
| 323.3   |     |      |   | 0.0        |   |
|         | 570 |      |   |            | 0 |

| REVISIONS |             |      |             |
|-----------|-------------|------|-------------|
| DATE      | DESCRIPTION | DATE | DESCRIPTION |
|           |             |      |             |

**Hatch Mott MacDonald**  
 Post Office Box 2518 Pensacola, Florida 32513  
 (850) 484-6011 - Certificate of Authorization #00000155  
 Engineer of Record: David D. Skipper, P.E. #58972

|  |          |                      |
|--|----------|----------------------|
| STATE OF FLORIDA<br>DEPARTMENT OF TRANSPORTATION |          |                      |
| ROAD NO.   | COUNTY   | FINANCIAL PROJECT ID |
|  | ESCAMBIA | 430002-1-52-01       |

**CROSS SECTIONS**

SHEET NO.





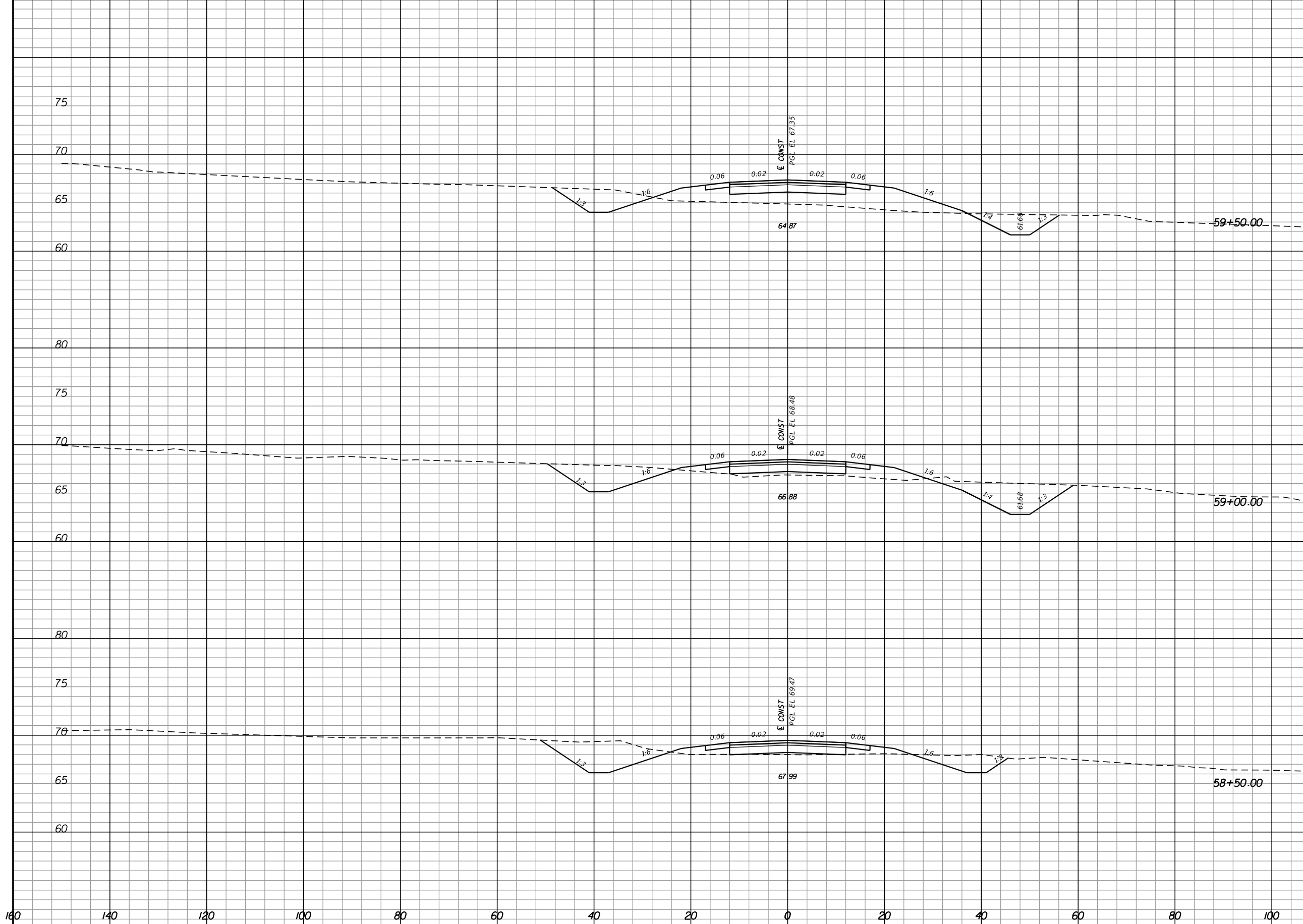

| Regular |     | Exc. |      | Embankment |    |
|---------|-----|------|------|------------|----|
| A       | V   | A    | V    | A          | V  |
| 54.0    |     |      | 86.6 |            |    |
| 94.1    | 137 | 28.1 |      | 106        |    |
| 71.7    | 154 | 16.5 |      | 41         |    |
|         | 195 |      |      |            | 15 |

| REVISIONS |             |      |             |
|-----------|-------------|------|-------------|
| DATE      | DESCRIPTION | DATE | DESCRIPTION |
|           |             |      |             |

**Hatch Mott MacDonald**  
 Post Office Box 2518 Pensacola, Florida 32513  
 (850) 484-6011 - Certificate of Authorization #00000155  
 Engineer of Record: David D. Skipper, P.E. #58972

|  |          |                      |
|--|----------|----------------------|
| STATE OF FLORIDA<br>DEPARTMENT OF TRANSPORTATION |          |                      |
| ROAD NO.   | COUNTY   | FINANCIAL PROJECT ID |
|  | ESCAMBIA | 430002-1-52-01       |

**CROSS SECTIONS**

|           |
|-----------|
| SHEET NO. |
|           |

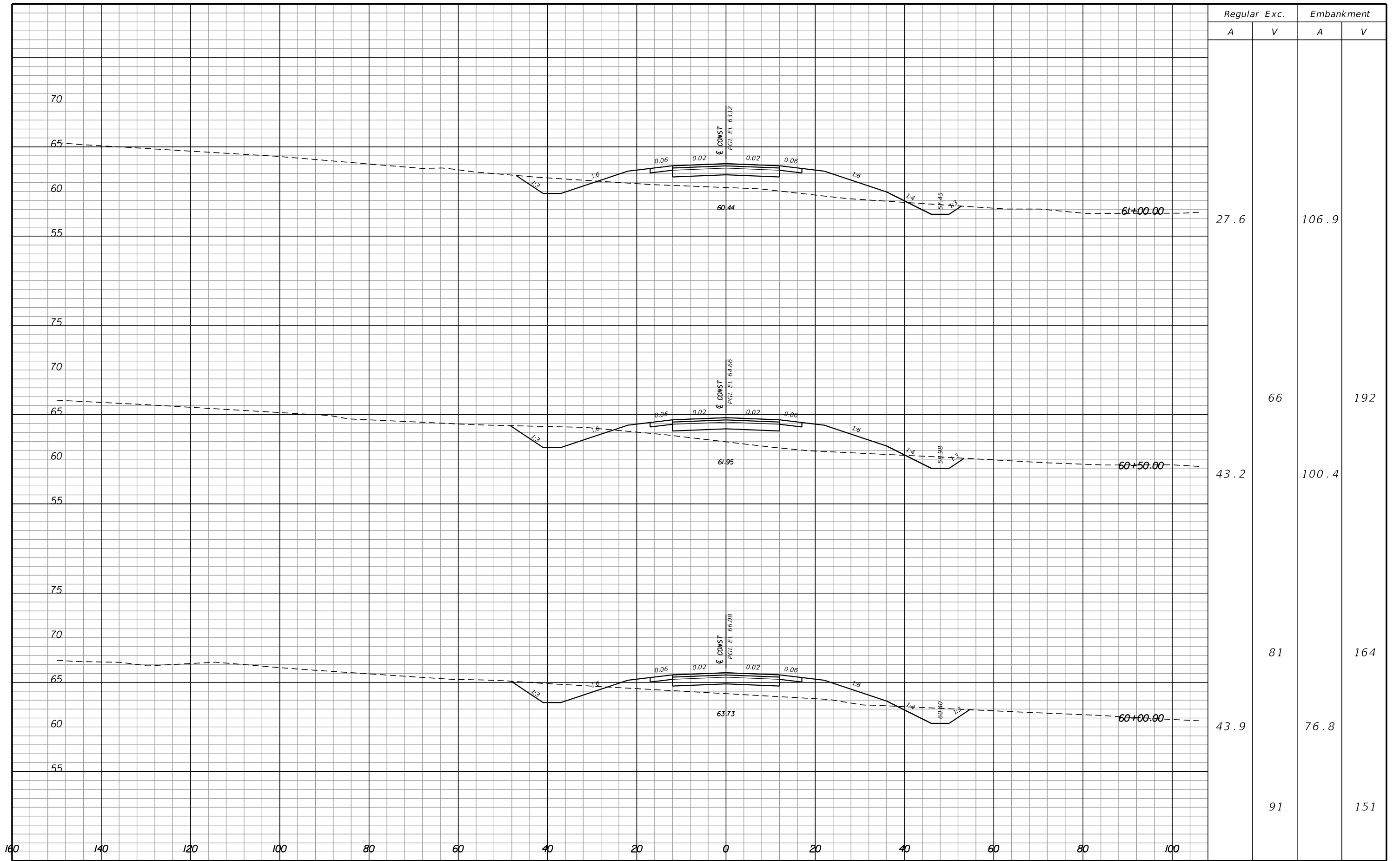

| REVISIONS |             |      |             |
|-----------|-------------|------|-------------|
| DATE      | DESCRIPTION | DATE | DESCRIPTION |
|           |             |      |             |

**Hatch Mott MacDonald**  
 Post Office Box 2518 Pensacola, Florida 32513  
 (850) 484-6011 - Certificate of Authorization #00000155  
 Engineer of Record: David D. Skipper, P.E. #58972

|  |          |                      |
|--|----------|----------------------|
| STATE OF FLORIDA<br>DEPARTMENT OF TRANSPORTATION |          |                      |
| ROAD NO.   | COUNTY   | FINANCIAL PROJECT ID |
|  | ESCAMBIA | 430002-1-52-01       |

**CROSS SECTIONS**

SHEET NO.

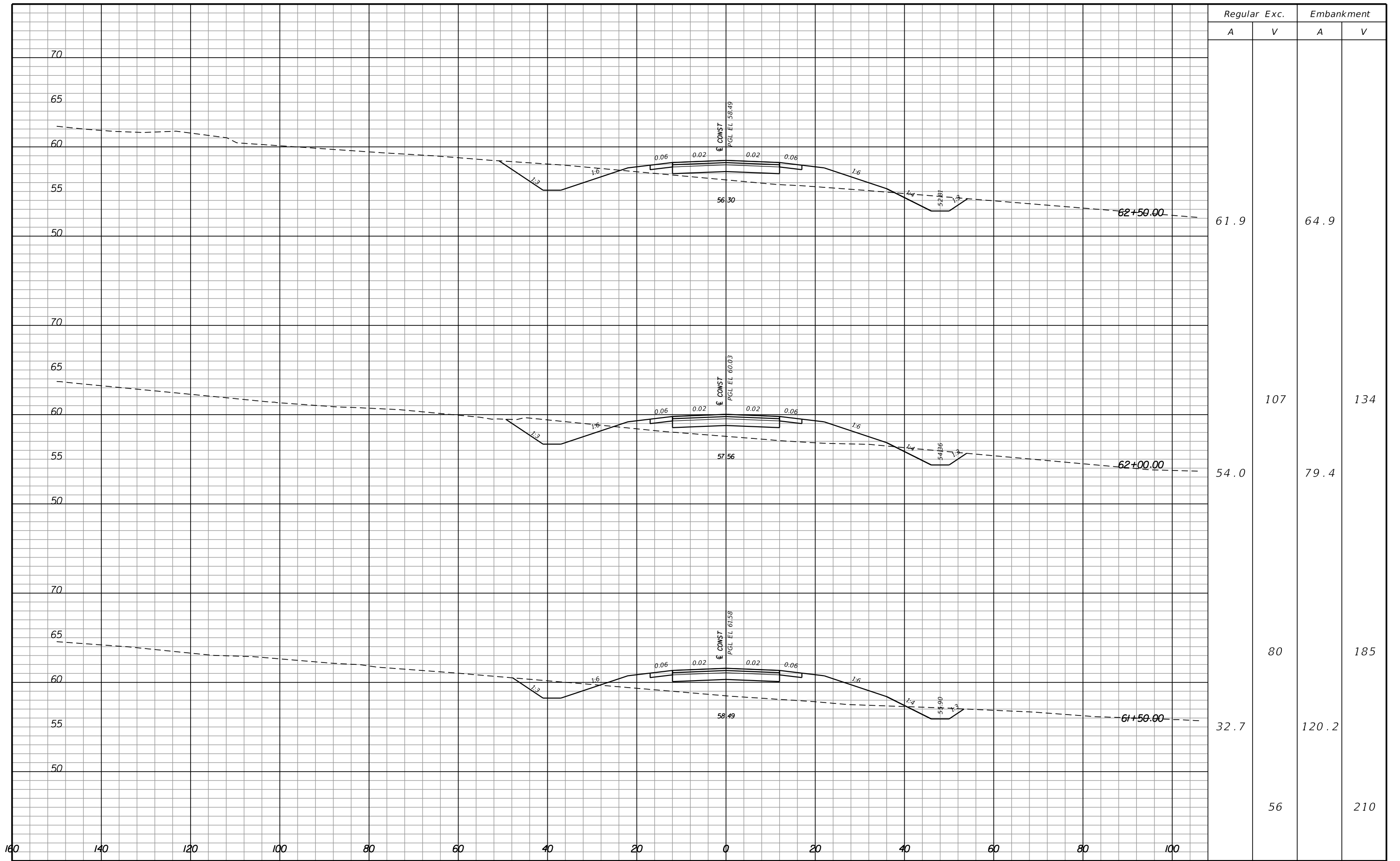

| REVISIONS |             |      |             |
|-----------|-------------|------|-------------|
| DATE      | DESCRIPTION | DATE | DESCRIPTION |
|           |             |      |             |



**Hatch Mott MacDonald**  
 Post Office Box 2518 Pensacola, Florida 32513  
 (850) 484-6011 - Certificate of Authorization #00000155  
 Engineer of Record: David D. Skipper, P.E. #58972

|  |          |                      |
|--|----------|----------------------|
| STATE OF FLORIDA<br>DEPARTMENT OF TRANSPORTATION |          |                      |
| ROAD NO.   | COUNTY   | FINANCIAL PROJECT ID |
|  | ESCAMBIA | 430002-1-52-01       |

**CROSS SECTIONS**

|           |
|-----------|
| SHEET NO. |
|           |



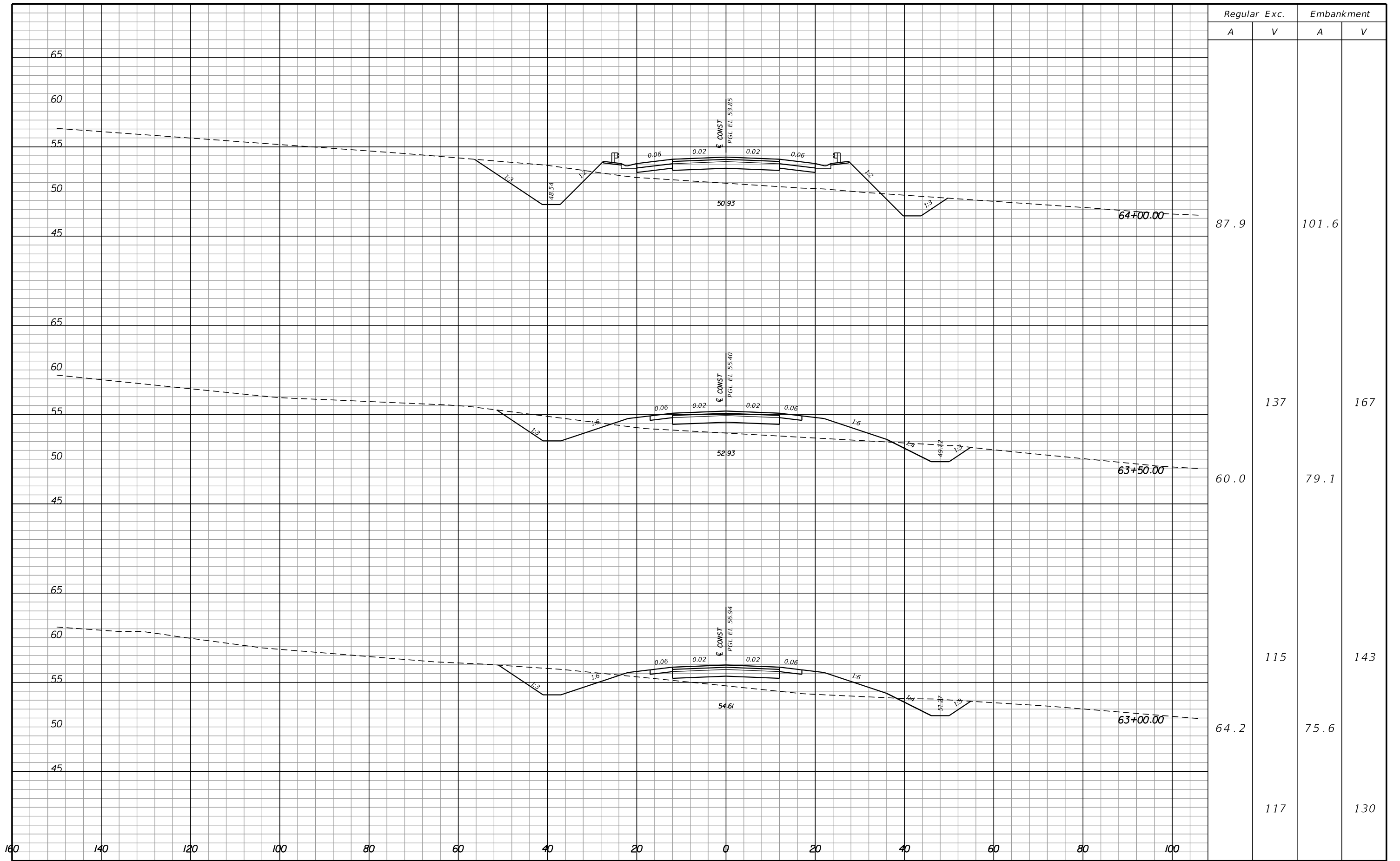

| Regular |   | Exc. |     | Embankment |       |
|---------|---|------|-----|------------|-------|
| A       | V | A    | V   | A          | V     |
|         |   |      |     | 87.9       | 101.6 |
|         |   |      | 137 | 60.0       | 167   |
|         |   |      |     | 115        | 143   |
|         |   |      | 117 | 64.2       | 130   |

| REVISIONS |             |      |             |
|-----------|-------------|------|-------------|
| DATE      | DESCRIPTION | DATE | DESCRIPTION |
|           |             |      |             |

**Hatch Mott MacDonald**  
 Post Office Box 2518 Pensacola, Florida 32513  
 (850) 484-6011 - Certificate of Authorization #00000155  
 Engineer of Record: David D. Skipper, P.E. #58972

|  |          |                      |
|--|----------|----------------------|
| STATE OF FLORIDA<br>DEPARTMENT OF TRANSPORTATION |          |                      |
| ROAD NO.   | COUNTY   | FINANCIAL PROJECT ID |
|  | ESCAMBIA | 430002-1-52-01       |

**CROSS SECTIONS**

SHEET NO.

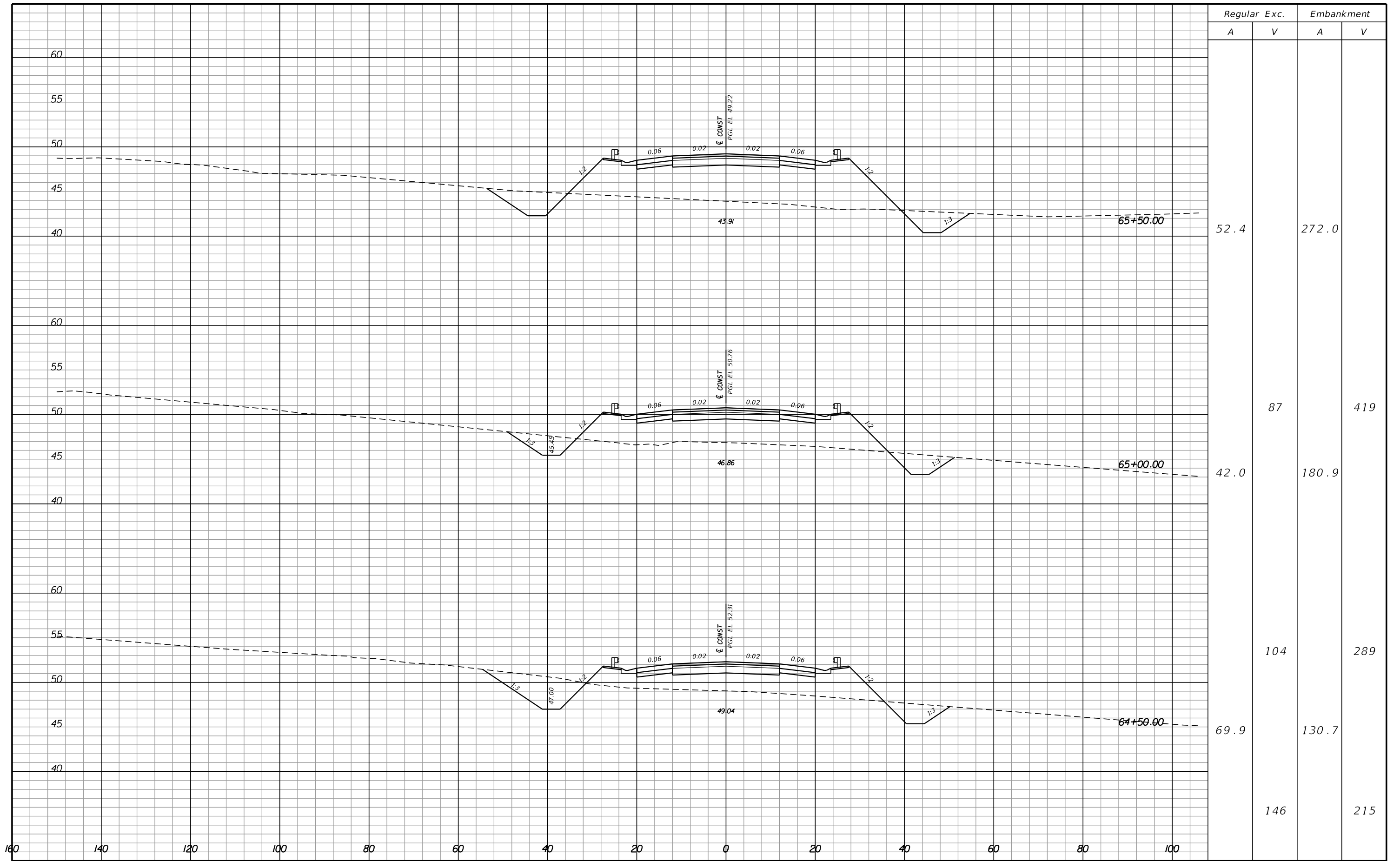

| REVISIONS |             |      |             |
|-----------|-------------|------|-------------|
| DATE      | DESCRIPTION | DATE | DESCRIPTION |
|           |             |      |             |



**Hatch Mott MacDonald**  
 Post Office Box 2518 Pensacola, Florida 32513  
 (850) 484-6011 - Certificate of Authorization #00000155  
 Engineer of Record: David D. Skipper, P.E. #58972

|  |          |                      |
|--|----------|----------------------|
| STATE OF FLORIDA<br>DEPARTMENT OF TRANSPORTATION |          |                      |
| ROAD NO.   | COUNTY   | FINANCIAL PROJECT ID |
|  | ESCAMBIA | 430002-1-52-01       |

CROSS SECTIONS

|           |  |
|-----------|--|
| SHEET NO. |  |
|-----------|--|

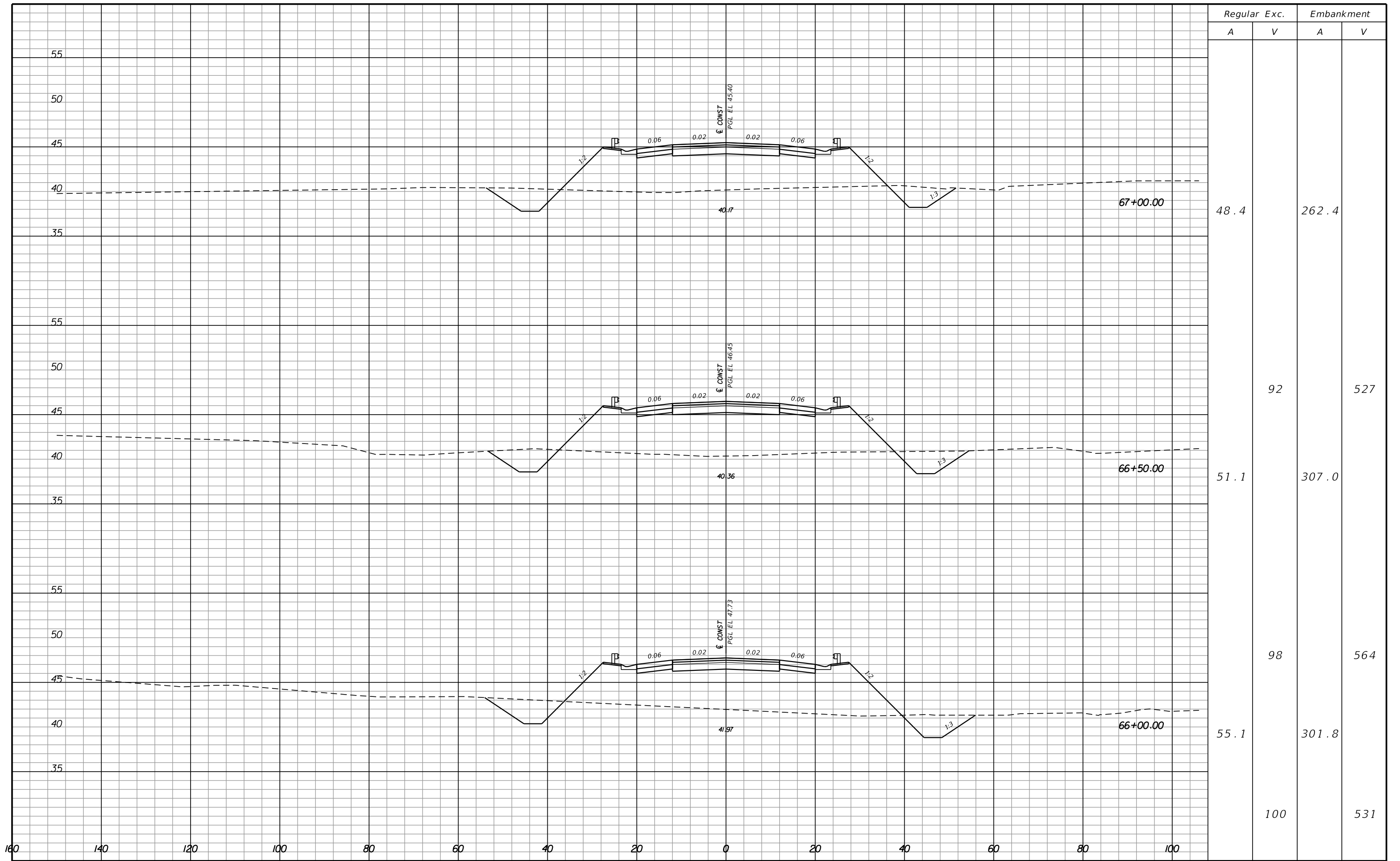

| Regular |     | Exc. |   | Embankment |     |
|---------|-----|------|---|------------|-----|
| A       | V   | A    | V | A          | V   |
| 48.4    |     |      |   | 262.4      |     |
| 51.1    | 92  |      |   | 307.0      | 527 |
| 55.1    | 98  |      |   | 301.8      | 564 |
|         | 100 |      |   |            | 531 |

| REVISIONS |             |      |             |
|-----------|-------------|------|-------------|
| DATE      | DESCRIPTION | DATE | DESCRIPTION |
|           |             |      |             |

**Hatch Mott MacDonald**  
 Post Office Box 2518 Pensacola, Florida 32513  
 (850) 484-6011 - Certificate of Authorization #00000155  
 Engineer of Record: David D. Skipper, P.E. #58972

|  |          |                      |
|--|----------|----------------------|
| STATE OF FLORIDA<br>DEPARTMENT OF TRANSPORTATION |          |                      |
| ROAD NO.   | COUNTY   | FINANCIAL PROJECT ID |
|  | ESCAMBIA | 430002-1-52-01       |

**CROSS SECTIONS**

SHEET NO.

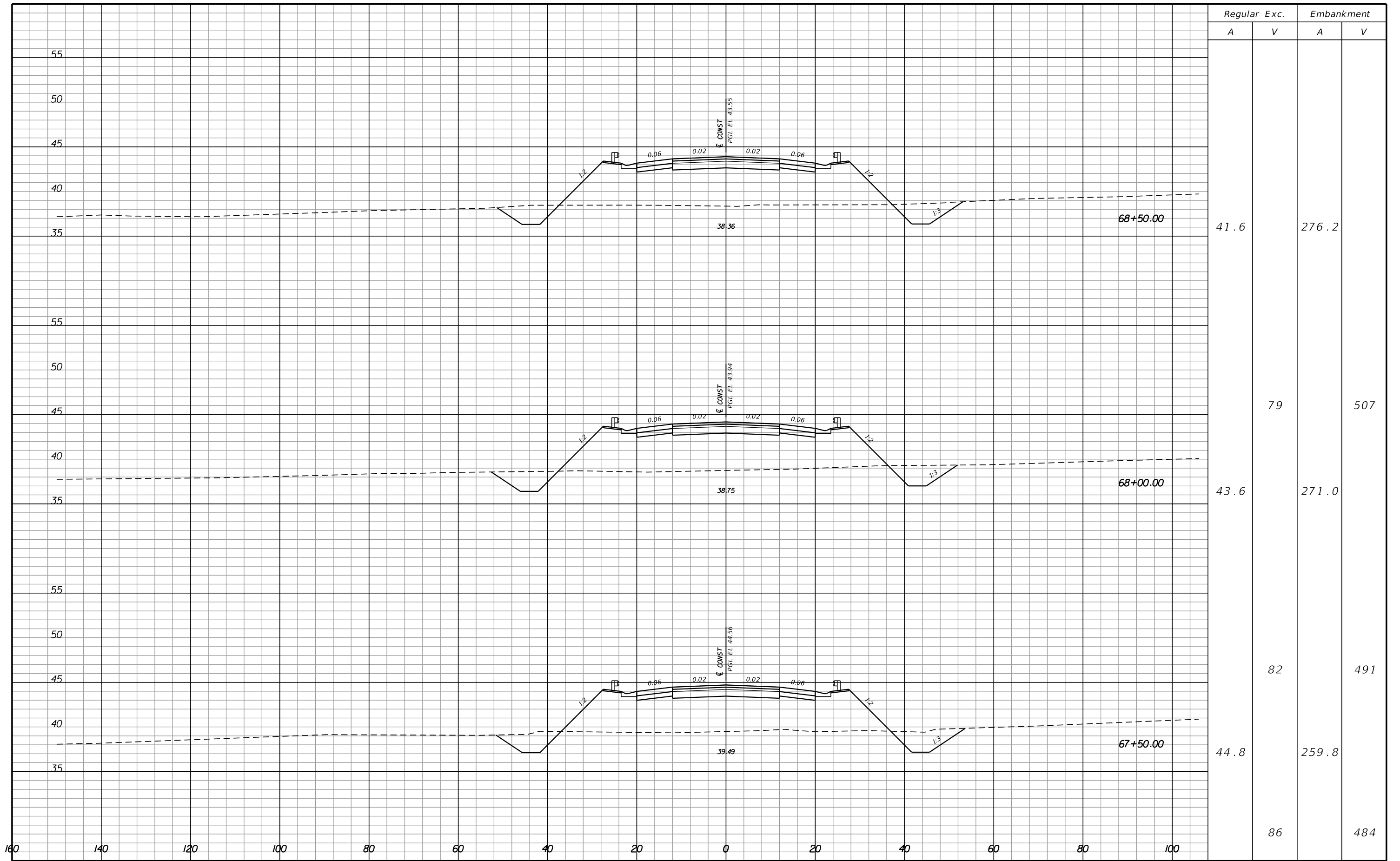

| REVISIONS |             |      |             |
|-----------|-------------|------|-------------|
| DATE      | DESCRIPTION | DATE | DESCRIPTION |
|           |             |      |             |

**Hatch Mott MacDonald**  
Post Office Box 2518 Pensacola, Florida 32513  
 (850) 484-6011 - Certificate of Authorization #00000155  
 Engineer of Record: David D. Skipper, P.E. #58972

| STATE OF FLORIDA<br>DEPARTMENT OF TRANSPORTATION |          |                      |
|--|----------|----------------------|
| ROAD NO.   | COUNTY   | FINANCIAL PROJECT ID |
|  | ESCAMBIA | 430002-1-52-01       |

CROSS SECTIONS

SHEET NO.

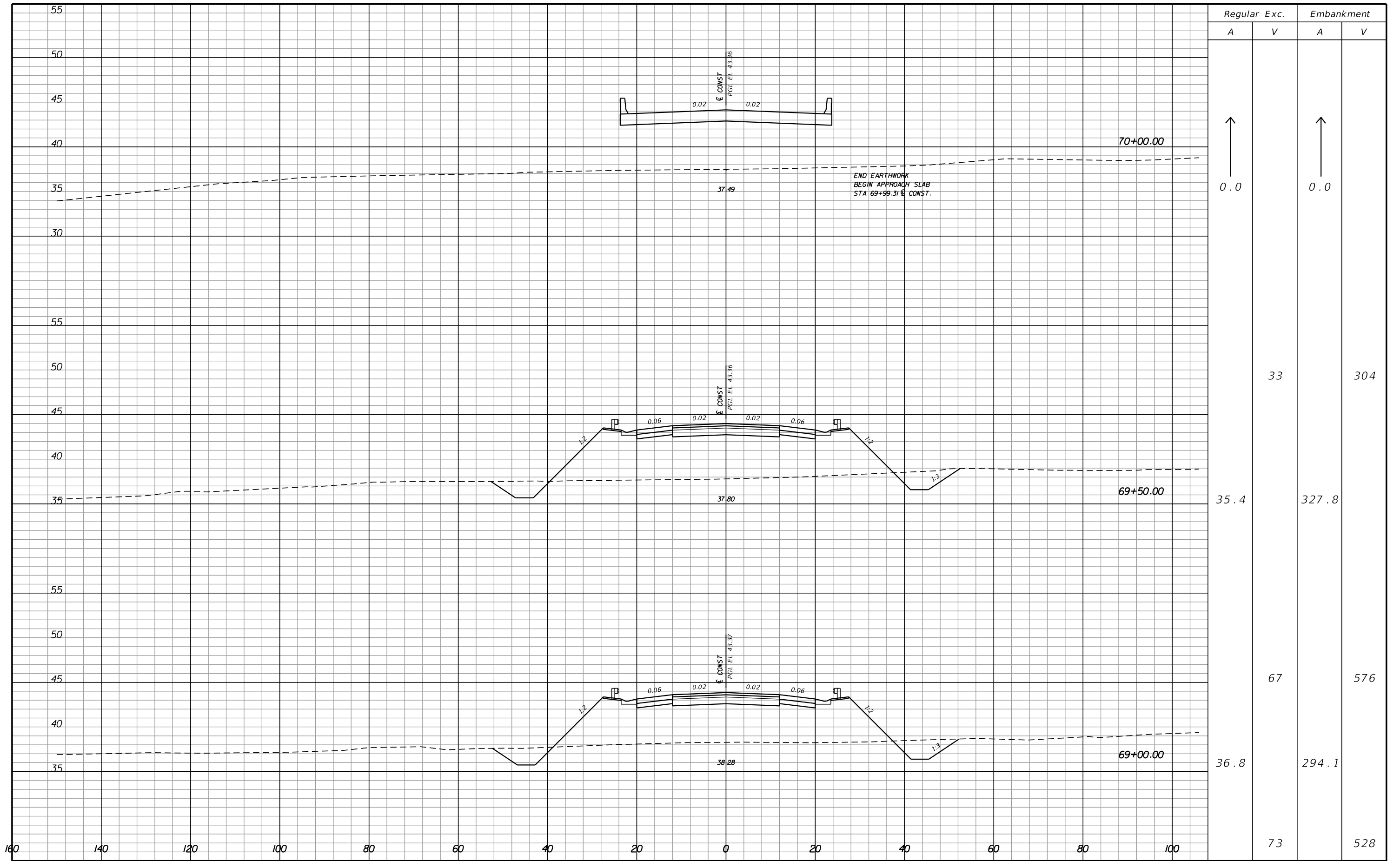

| Regular Exc. |    | Embankment |     |
|--------------|----|------------|-----|
| A            | V  | A          | V   |
| 0.0          |    | 0.0        |     |
| 35.4         | 33 | 327.8      | 304 |
| 36.8         | 67 | 294.1      | 576 |
| 73           |    | 528        |     |

| REVISIONS |             |      |             |
|-----------|-------------|------|-------------|
| DATE      | DESCRIPTION | DATE | DESCRIPTION |
|           |             |      |             |

**Hatch Mott MacDonald**  
 Post Office Box 2518 Pensacola, Florida 32513  
 (850) 484-6011 - Certificate of Authorization #00000155  
 Engineer of Record: David D. Skipper, P.E. #58972

|  |          |                      |
|--|----------|----------------------|
| STATE OF FLORIDA<br>DEPARTMENT OF TRANSPORTATION |          |                      |
| ROAD NO.   | COUNTY   | FINANCIAL PROJECT ID |
|  | ESCAMBIA | 430002-1-52-01       |

**CROSS SECTIONS**

SHEET NO.



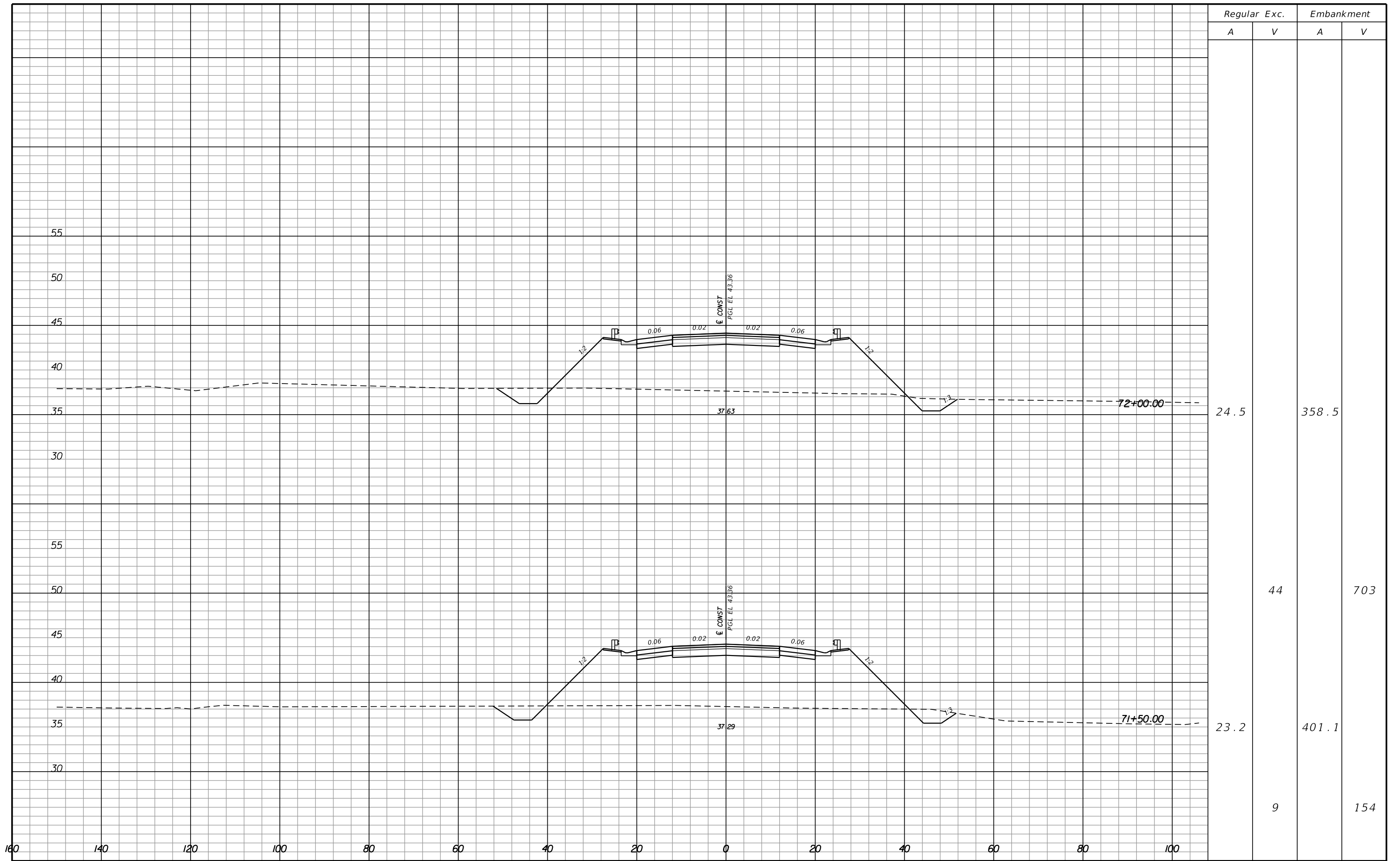

| Regular |    | Exc. |   | Embankment |     |
|---------|----|------|---|------------|-----|
| A       | V  | A    | V | A          | V   |
| 24.5    |    |      |   | 358.5      |     |
|         | 44 |      |   |            | 703 |
| 23.2    |    |      |   | 401.1      |     |
|         | 9  |      |   |            | 154 |

| REVISIONS |             |      |             |
|-----------|-------------|------|-------------|
| DATE      | DESCRIPTION | DATE | DESCRIPTION |
|           |             |      |             |

**Hatch Mott MacDonald**  
 Post Office Box 2518 Pensacola, Florida 32513  
 (850) 484-6011 - Certificate of Authorization #00000155  
 Engineer of Record: David D. Skipper, P.E. #58972

|  |          |                      |
|--|----------|----------------------|
| STATE OF FLORIDA<br>DEPARTMENT OF TRANSPORTATION |          |                      |
| ROAD NO.   | COUNTY   | FINANCIAL PROJECT ID |
|  | ESCAMBIA | 430002-1-52-01       |

CROSS SECTIONS

|              |
|--------------|
| SHEET<br>NO. |
|--------------|

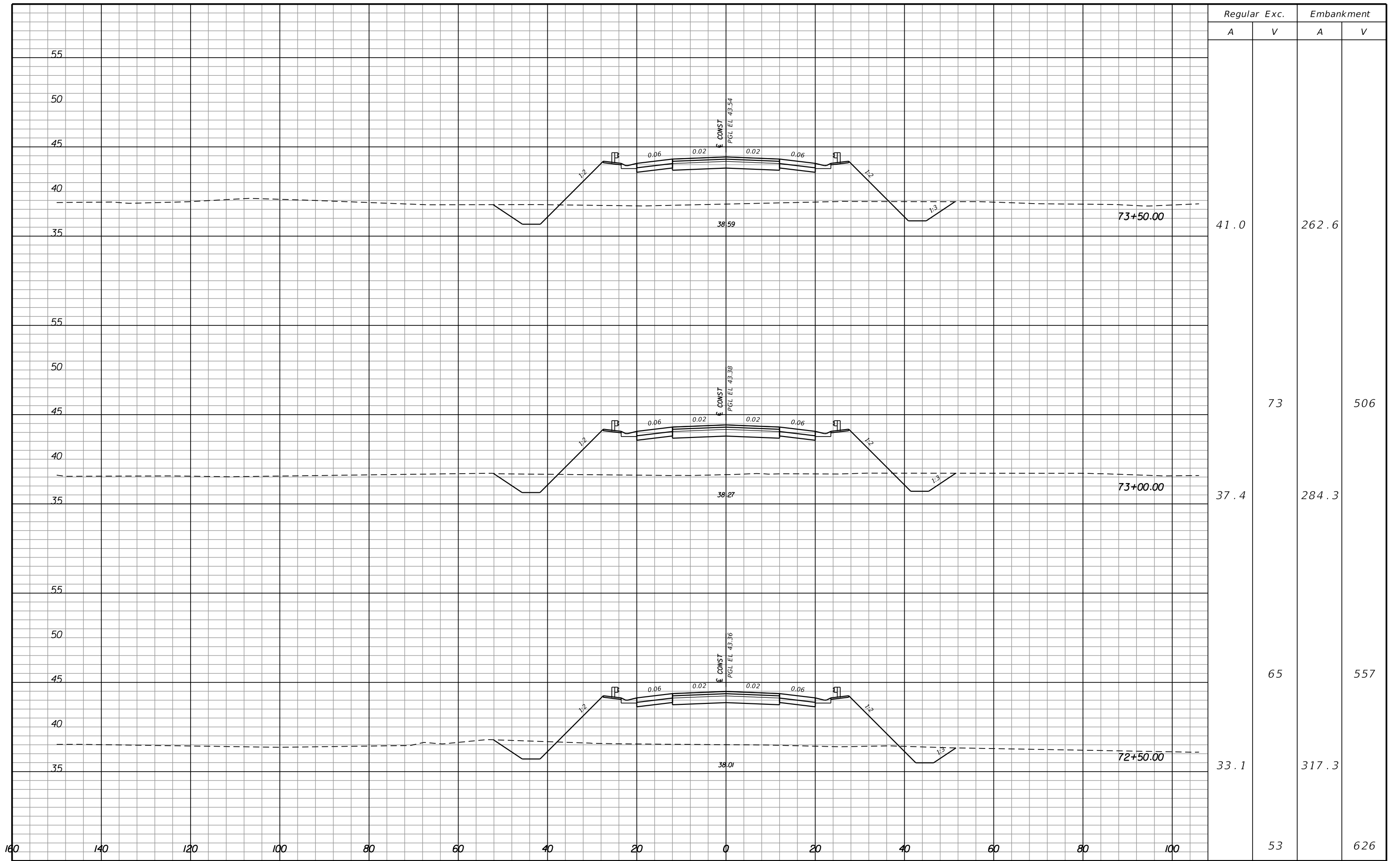

| Regular Exc. |    | Embankment |     |
|--------------|----|------------|-----|
| A            | V  | A          | V   |
| 41.0         |    | 262.6      |     |
| 37.4         | 73 | 284.3      | 506 |
| 33.1         | 65 | 317.3      | 557 |
|              | 53 |            | 626 |

| REVISIONS |             |      |             |
|-----------|-------------|------|-------------|
| DATE      | DESCRIPTION | DATE | DESCRIPTION |
|           |             |      |             |



**Hatch Mott MacDonald**  
 Post Office Box 2518 Pensacola, Florida 32513  
 (850) 484-6011 - Certificate of Authorization #00000155  
 Engineer of Record: David D. Skipper, P.E. #58972

|  |          |                      |
|--|----------|----------------------|
| STATE OF FLORIDA<br>DEPARTMENT OF TRANSPORTATION |          |                      |
| ROAD NO.   | COUNTY   | FINANCIAL PROJECT ID |
|  | ESCAMBIA | 430002-1-52-01       |

**CROSS SECTIONS**

|           |
|-----------|
| SHEET NO. |
|           |



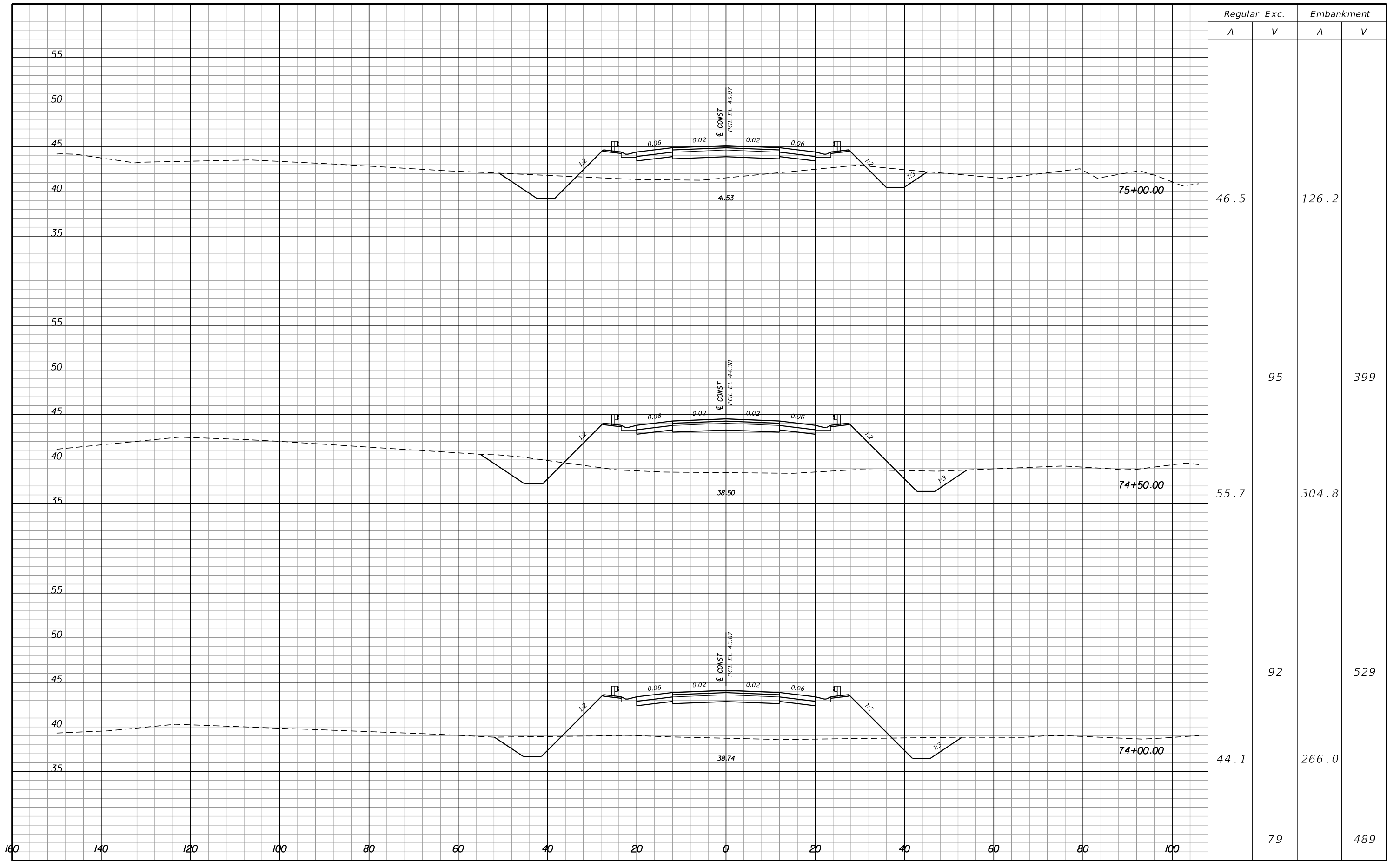

| Regular |    | Exc. |   | Embankment |     |
|---------|----|------|---|------------|-----|
| A       | V  | A    | V | A          | V   |
| 46.5    |    |      |   | 126.2      |     |
| 55.7    | 95 |      |   | 304.8      | 399 |
| 44.1    |    |      |   | 266.0      |     |
|         | 79 |      |   |            | 489 |

| REVISIONS |             |      |             |
|-----------|-------------|------|-------------|
| DATE      | DESCRIPTION | DATE | DESCRIPTION |
|           |             |      |             |

**Hatch Mott MacDonald**  
 Post Office Box 2518 Pensacola, Florida 32513  
 (850) 484-6011 - Certificate of Authorization #00000155  
 Engineer of Record: David D. Skipper, P.E. #58972

|  |          |                      |
|--|----------|----------------------|
| STATE OF FLORIDA<br>DEPARTMENT OF TRANSPORTATION |          |                      |
| ROAD NO.   | COUNTY   | FINANCIAL PROJECT ID |
|  | ESCAMBIA | 430002-1-52-01       |

**CROSS SECTIONS**

SHEET NO.

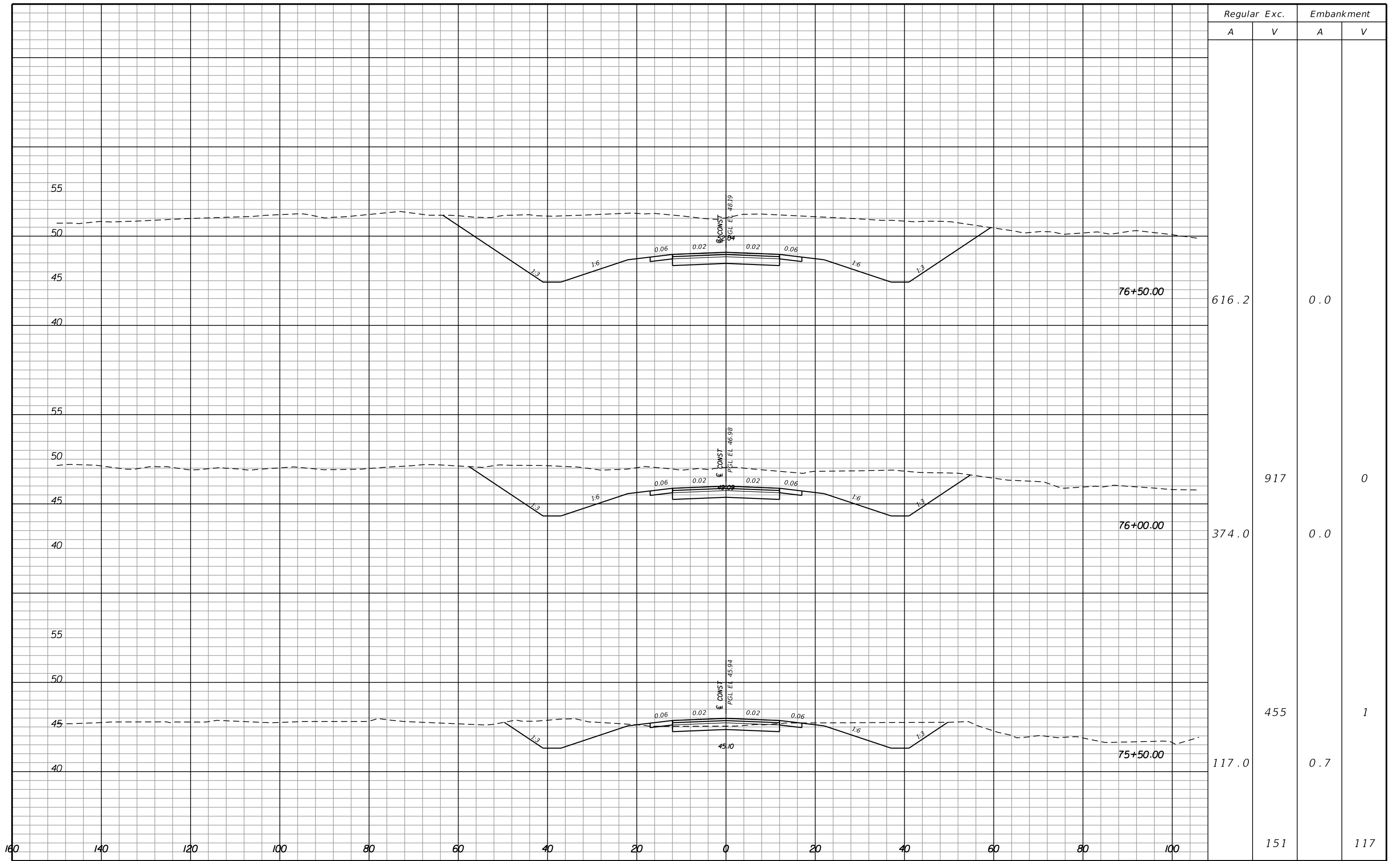

| REVISIONS |             |      |             |
|-----------|-------------|------|-------------|
| DATE      | DESCRIPTION | DATE | DESCRIPTION |
|           |             |      |             |



**Hatch Mott  
MacDonald**  
Post Office Box 2518 Pensacola, Florida 32513  
(850) 484-6011 - Certificate of Authorization #00000155  
Engineer of Record: David D. Skipper, P.E. #58972

|  |          |                      |
|--|----------|----------------------|
| STATE OF FLORIDA<br>DEPARTMENT OF TRANSPORTATION |          |                      |
| ROAD NO.   | COUNTY   | FINANCIAL PROJECT ID |
|  | ESCAMBIA | 430002-1-52-01       |

**CROSS SECTIONS**

SHEET NO.

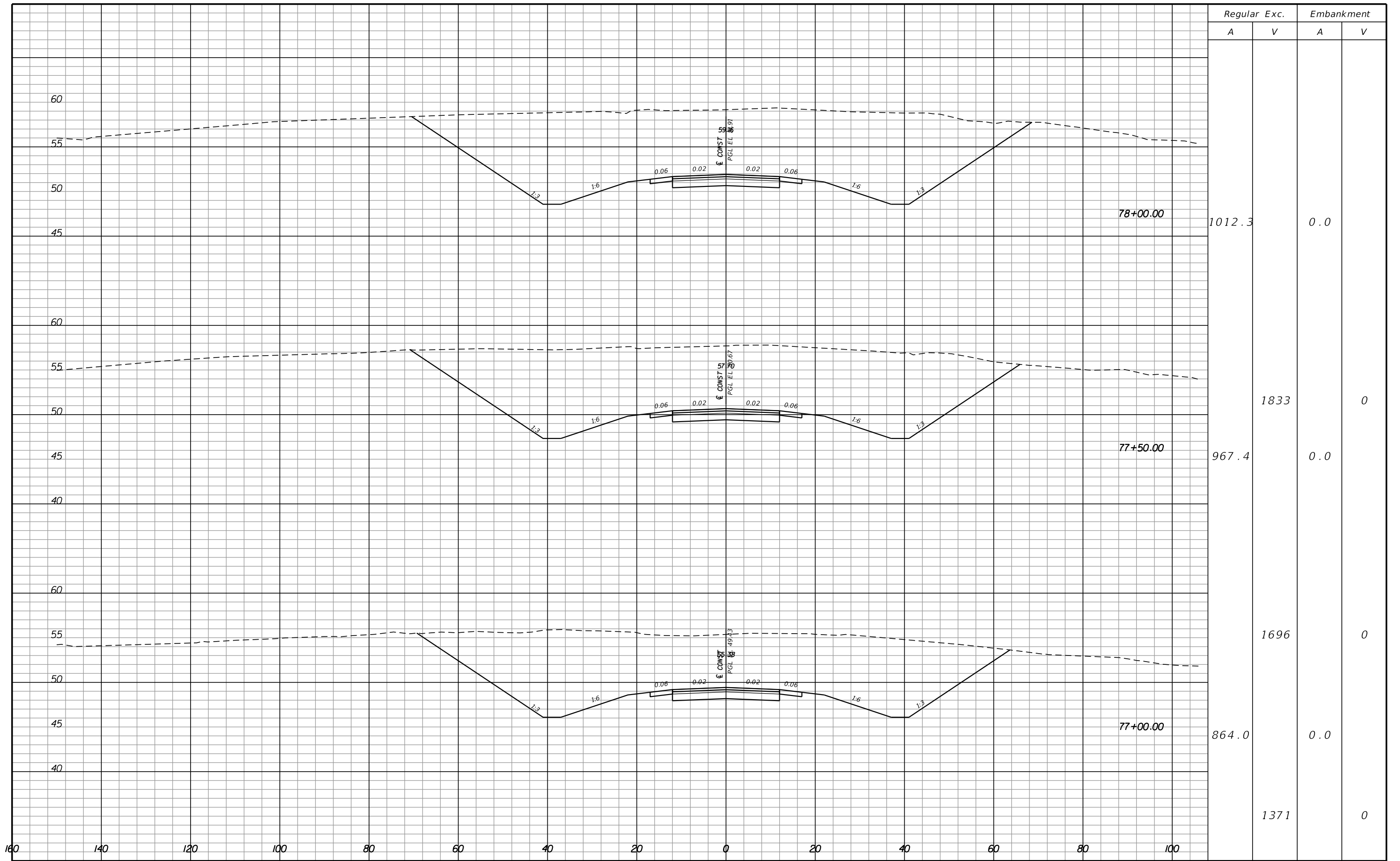

|          | Regular Exc. |      | Embankment |     |
|----------|--------------|------|------------|-----|
|          | A            | V    | A          | V   |
| 78+00.00 | 1012.3       | 0.0  | 0.0        | 0.0 |
| 77+50.00 | 967.4        | 1833 | 0.0        | 0   |
| 77+00.00 | 864.0        | 1696 | 0.0        | 0   |
|          |              | 1371 |            | 0   |

| REVISIONS |             |      |             |
|-----------|-------------|------|-------------|
| DATE      | DESCRIPTION | DATE | DESCRIPTION |
|           |             |      |             |

**Hatch Mott MacDonald**  
 Post Office Box 2518 Pensacola, Florida 32513  
 (850) 484-6011 - Certificate of Authorization #00000155  
 Engineer of Record: David D. Skipper, P.E. #58972

|  |          |                      |
|--|----------|----------------------|
| STATE OF FLORIDA<br>DEPARTMENT OF TRANSPORTATION |          |                      |
| ROAD NO.   | COUNTY   | FINANCIAL PROJECT ID |
|  | ESCAMBIA | 430002-1-52-01       |

CROSS SECTIONS

|           |
|-----------|
| SHEET NO. |
|           |

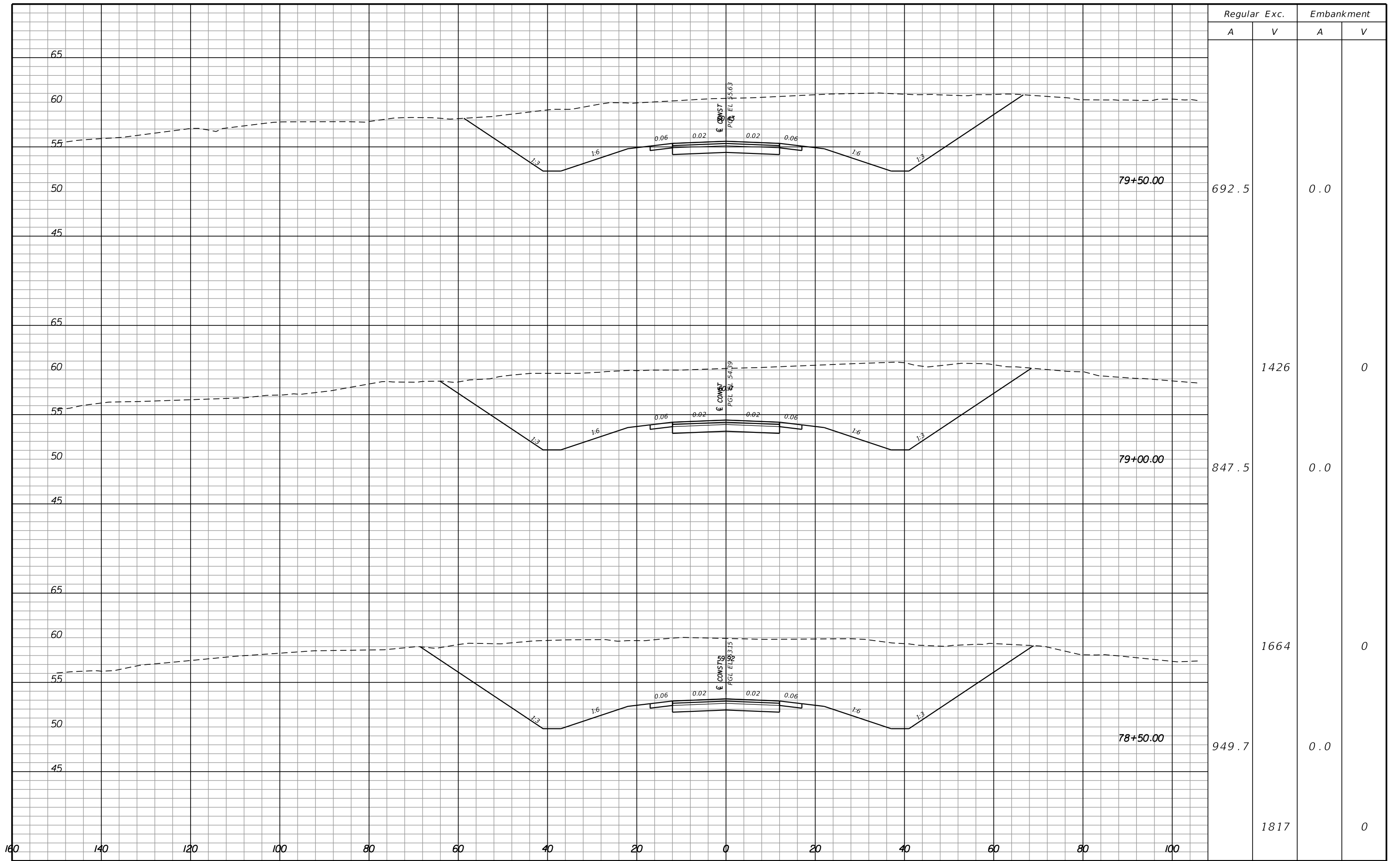

| Regular |      | Exc. |   | Embankment |   |
|---------|------|------|---|------------|---|
| A       | V    | A    | V | A          | V |
| 692.5   |      |      |   | 0.0        |   |
| 847.5   | 1426 |      |   | 0.0        | 0 |
| 949.7   | 1664 |      |   | 0.0        | 0 |
|         | 1817 |      |   |            | 0 |

| REVISIONS |             |      |             |
|-----------|-------------|------|-------------|
| DATE      | DESCRIPTION | DATE | DESCRIPTION |
|           |             |      |             |

**Hatch Mott MacDonald**  
 Post Office Box 2518 Pensacola, Florida 32513  
 (850) 484-6011 - Certificate of Authorization #00000155  
 Engineer of Record: David D. Skipper, P.E. #58972

|  |          |                      |
|--|----------|----------------------|
| STATE OF FLORIDA<br>DEPARTMENT OF TRANSPORTATION |          |                      |
| ROAD NO.   | COUNTY   | FINANCIAL PROJECT ID |
|  | ESCAMBIA | 430002-1-52-01       |

**CROSS SECTIONS**

|           |
|-----------|
| SHEET NO. |
|           |

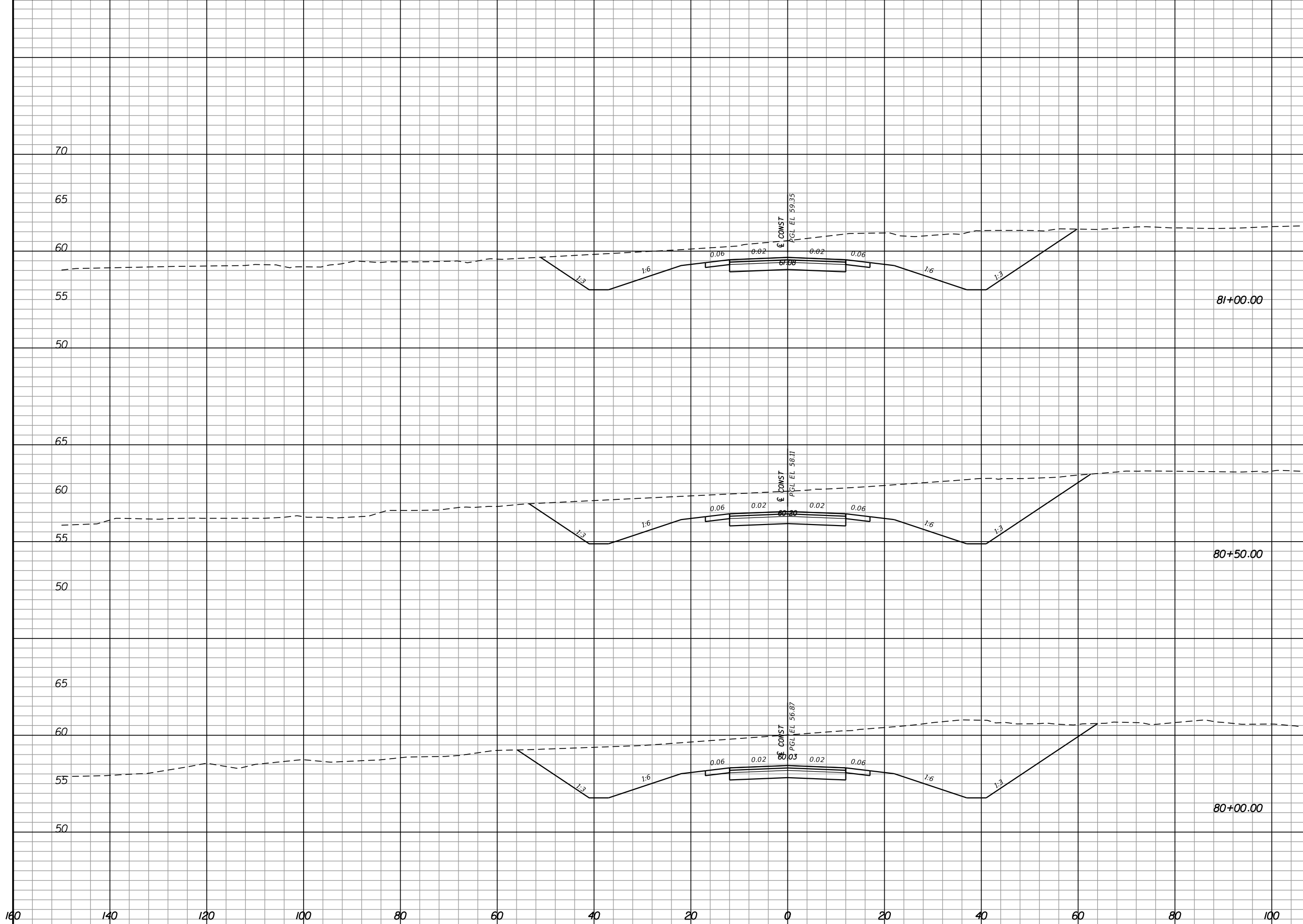

| Regular Exc. |     | Embankment |   |
|--------------|-----|------------|---|
| A            | V   | A          | V |
| 345.8        |     | 0.0        |   |
| 413.4        | 703 | 0.0        | 0 |
| 528.1        | 872 | 0.0        | 0 |
| 1130         |     | 0          |   |

| REVISIONS |             |      |             |
|-----------|-------------|------|-------------|
| DATE      | DESCRIPTION | DATE | DESCRIPTION |
|           |             |      |             |

**Hatch Mott MacDonald**  
 Post Office Box 2518 Pensacola, Florida 32513  
 (850) 484-6011 - Certificate of Authorization #00000155  
 Engineer of Record: David D. Skipper, P.E. #58972

|  |          |                      |
|--|----------|----------------------|
| STATE OF FLORIDA<br>DEPARTMENT OF TRANSPORTATION |          |                      |
| ROAD NO.   | COUNTY   | FINANCIAL PROJECT ID |
|  | ESCAMBIA | 430002-1-52-01       |

**CROSS SECTIONS**

SHEET NO.

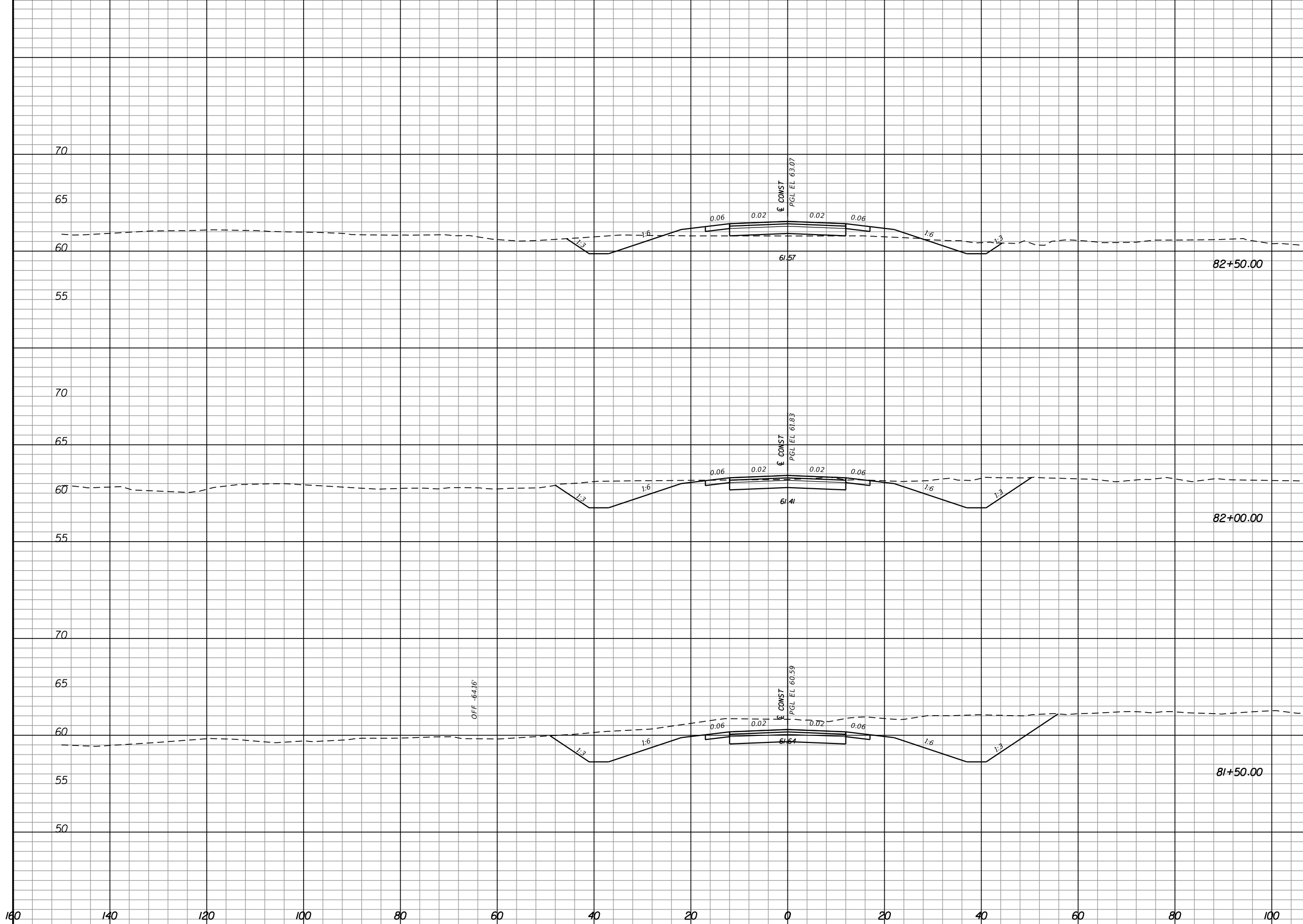

| Regular Exc. |     | Embankment |    |
|--------------|-----|------------|----|
| A            | V   | A          | V  |
| 34.2         |     | 21.1       |    |
| 123.2        | 146 | 0.0        | 20 |
| 256.3        | 351 | 0.0        | 0  |
|              | 558 |            | 0  |

| REVISIONS |             |      |             |
|-----------|-------------|------|-------------|
| DATE      | DESCRIPTION | DATE | DESCRIPTION |
|           |             |      |             |

**Hatch Mott MacDonald**  
 Post Office Box 2518 Pensacola, Florida 32513  
 (850) 484-6011 - Certificate of Authorization #00000155  
 Engineer of Record: David D. Skipper, P.E. #58972

|  |          |                      |
|--|----------|----------------------|
| STATE OF FLORIDA<br>DEPARTMENT OF TRANSPORTATION |          |                      |
| ROAD NO.   | COUNTY   | FINANCIAL PROJECT ID |
|  | ESCAMBIA | 430002-1-52-01       |

**CROSS SECTIONS**

SHEET NO.

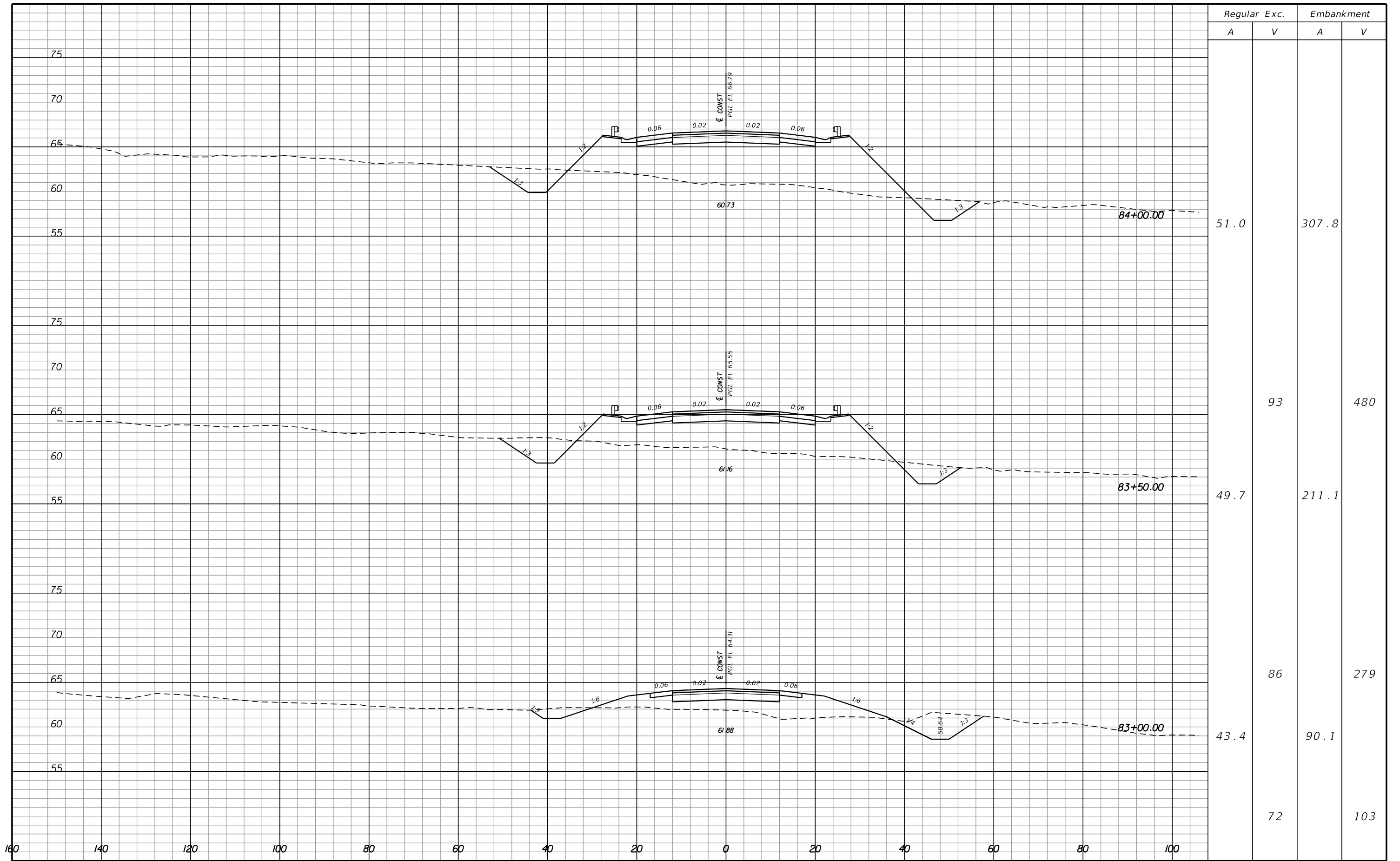

| REVISIONS |             |      |             |
|-----------|-------------|------|-------------|
| DATE      | DESCRIPTION | DATE | DESCRIPTION |
|           |             |      |             |



**Hatch Mott MacDonald**  
 Post Office Box 2518 Pensacola, Florida 32513  
 (850) 484-6011 - Certificate of Authorization #00000155  
 Engineer of Record: David D. Skipper, P.E. #58972

|  |          |                      |
|--|----------|----------------------|
| STATE OF FLORIDA<br>DEPARTMENT OF TRANSPORTATION |          |                      |
| ROAD NO.   | COUNTY   | FINANCIAL PROJECT ID |
|  | ESCAMBIA | 430002-1-52-01       |

*CROSS SECTIONS*

|           |
|-----------|
| SHEET NO. |
|           |

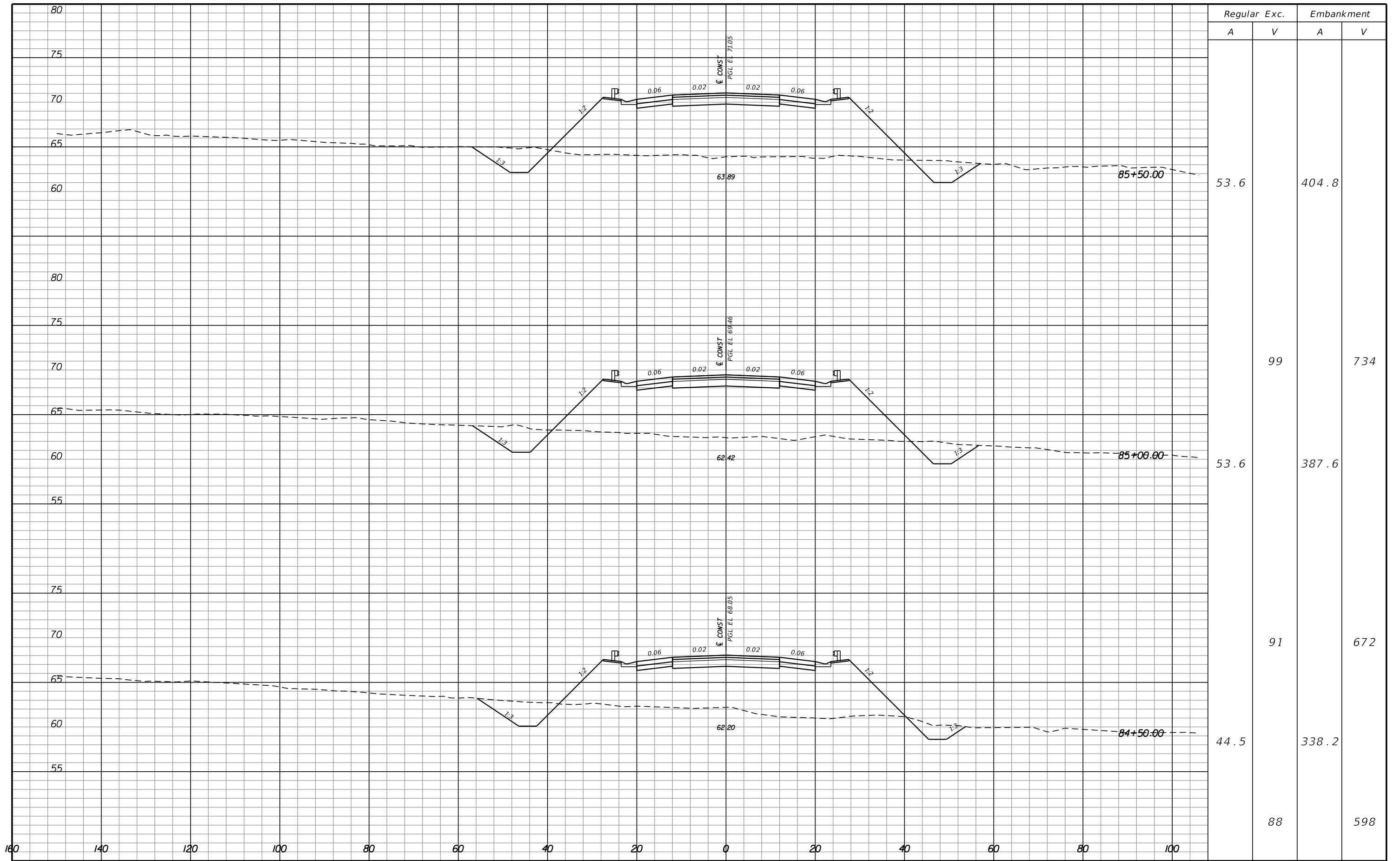

| Regular |    | Exc. |   | Embankment |     |
|---------|----|------|---|------------|-----|
| A       | V  | A    | V | A          | V   |
| 53.6    |    |      |   | 404.8      |     |
| 53.6    | 99 |      |   | 387.6      | 734 |
| 44.5    | 91 |      |   | 338.2      | 672 |
|         | 88 |      |   |            | 598 |

| REVISIONS |             |      |             |
|-----------|-------------|------|-------------|
| DATE      | DESCRIPTION | DATE | DESCRIPTION |
|           |             |      |             |

**Hatch Mott MacDonald**  
 Post Office Box 2518 Pensacola, Florida 32513  
 (850) 484-6011 - Certificate of Authorization #00000155  
 Engineer of Record: David D. Skipper, P.E. #58972

STATE OF FLORIDA  
 DEPARTMENT OF TRANSPORTATION

|          |          |                      |
|----------|----------|----------------------|
| ROAD NO. | COUNTY   | FINANCIAL PROJECT ID |
|          | ESCAMBIA | 430002-1-52-01       |

**CROSS SECTIONS**

SHEET NO.



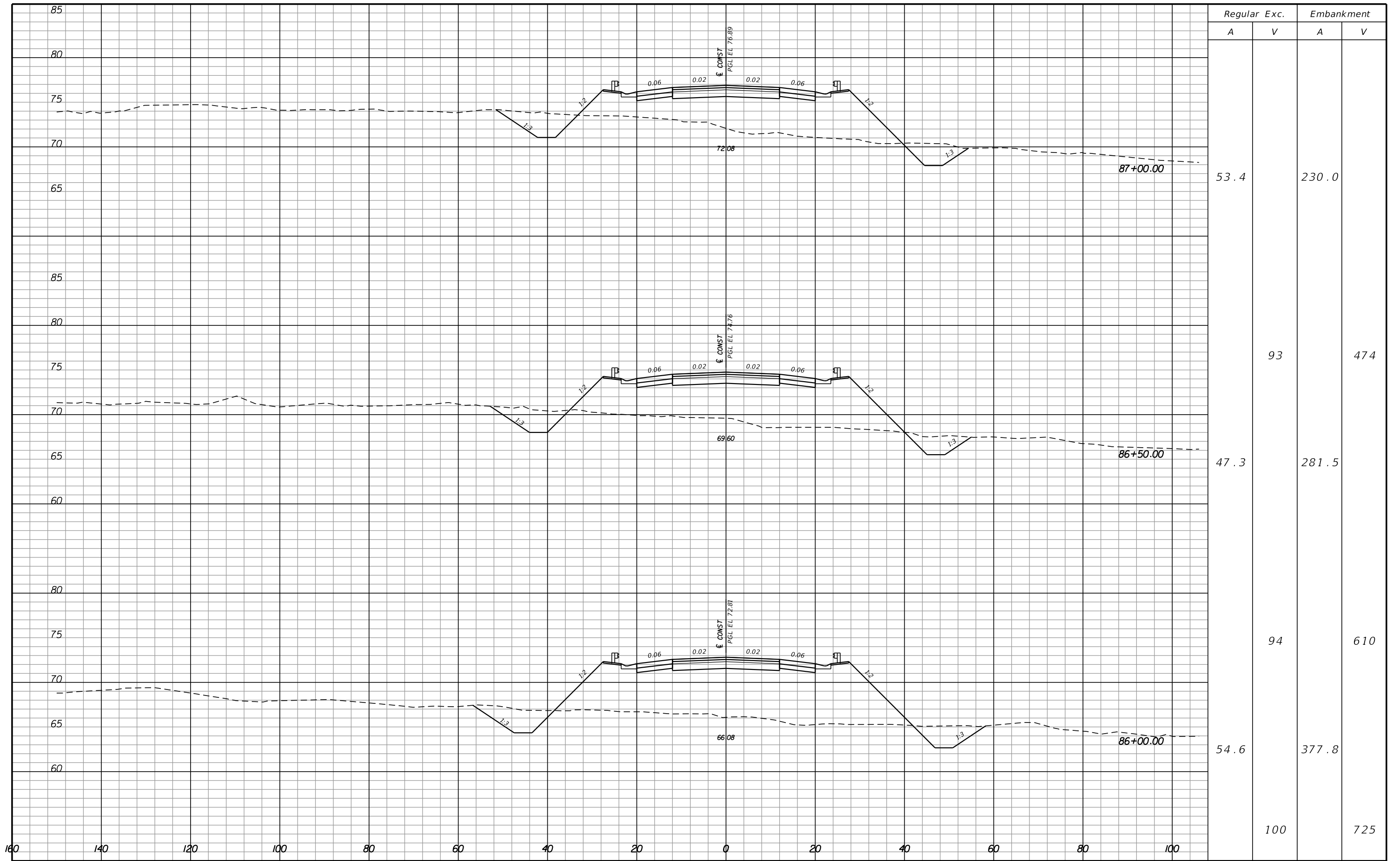

| REVISIONS |             |      |             |
|-----------|-------------|------|-------------|
| DATE      | DESCRIPTION | DATE | DESCRIPTION |
|           |             |      |             |



**Hatch Mott  
MacDonald**  
Post Office Box 2518 Pensacola, Florida 32513  
(850) 484-6011 - Certificate of Authorization #00000155  
Engineer of Record: David D. Skipper, P.E. #58972

|  |          |                      |
|--|----------|----------------------|
| STATE OF FLORIDA<br>DEPARTMENT OF TRANSPORTATION |          |                      |
| ROAD NO.   | COUNTY   | FINANCIAL PROJECT ID |
|  | ESCAMBIA | 430002-1-52-01       |

**CROSS SECTIONS**

SHEET NO.





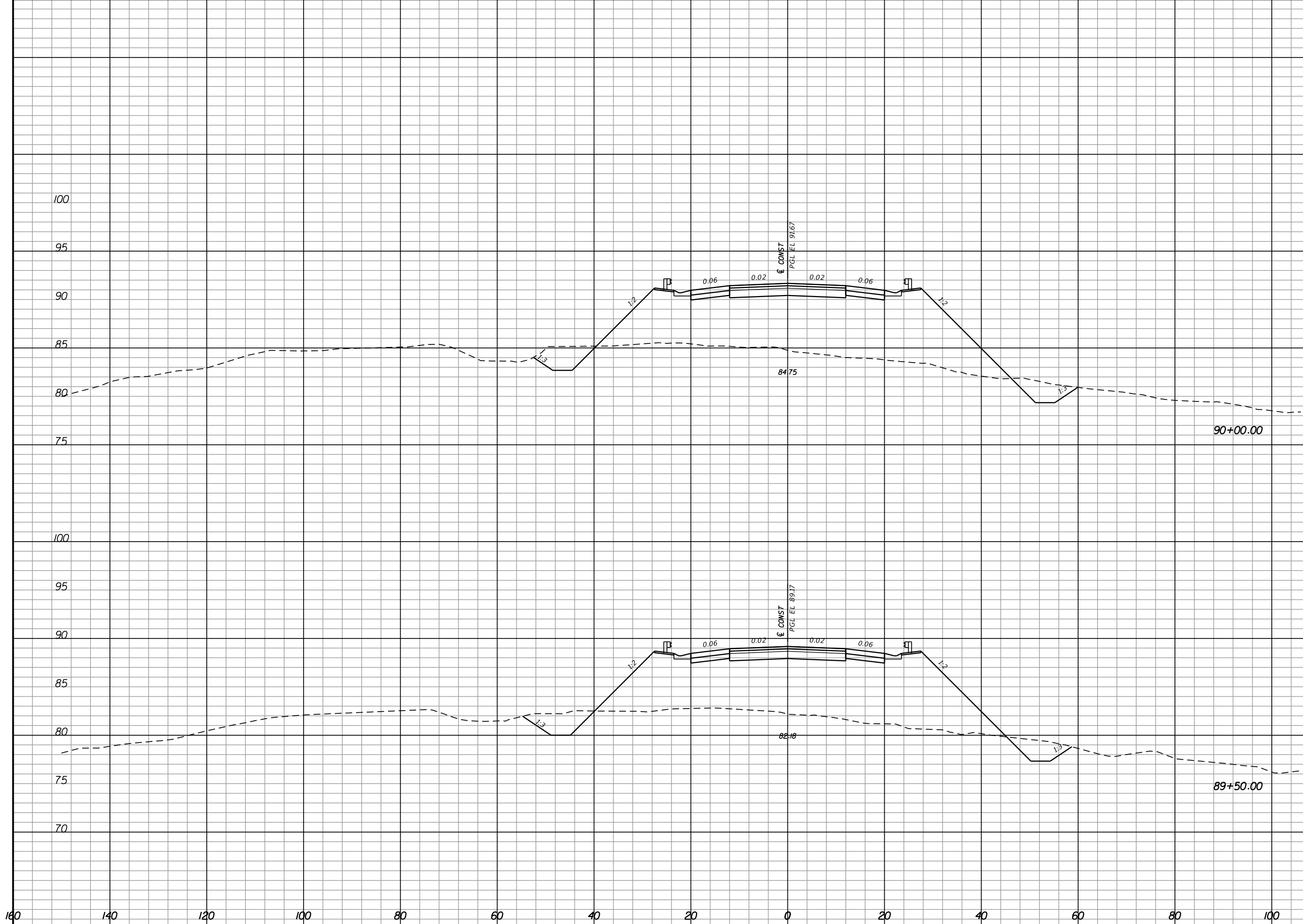

| Regular |    | Exc. |   | Embankment |     |
|---------|----|------|---|------------|-----|
| A       | V  | A    | V | A          | V   |
| 40.1    |    |      |   | 425.9      |     |
|         | 75 |      |   |            | 791 |
| 40.9    |    |      |   | 428.5      |     |
|         | 85 |      |   |            | 792 |

| REVISIONS |             |      |             |
|-----------|-------------|------|-------------|
| DATE      | DESCRIPTION | DATE | DESCRIPTION |
|           |             |      |             |

**Hatch Mott MacDonald**  
 Post Office Box 2518 Pensacola, Florida 32513  
 (850) 484-6011 - Certificate of Authorization #00000155  
 Engineer of Record: David D. Skipper, P.E. #58972

|  |          |                      |
|--|----------|----------------------|
| STATE OF FLORIDA<br>DEPARTMENT OF TRANSPORTATION |          |                      |
| ROAD NO.   | COUNTY   | FINANCIAL PROJECT ID |
|  | ESCAMBIA | 430002-1-52-01       |

**CROSS SECTIONS**

SHEET NO.

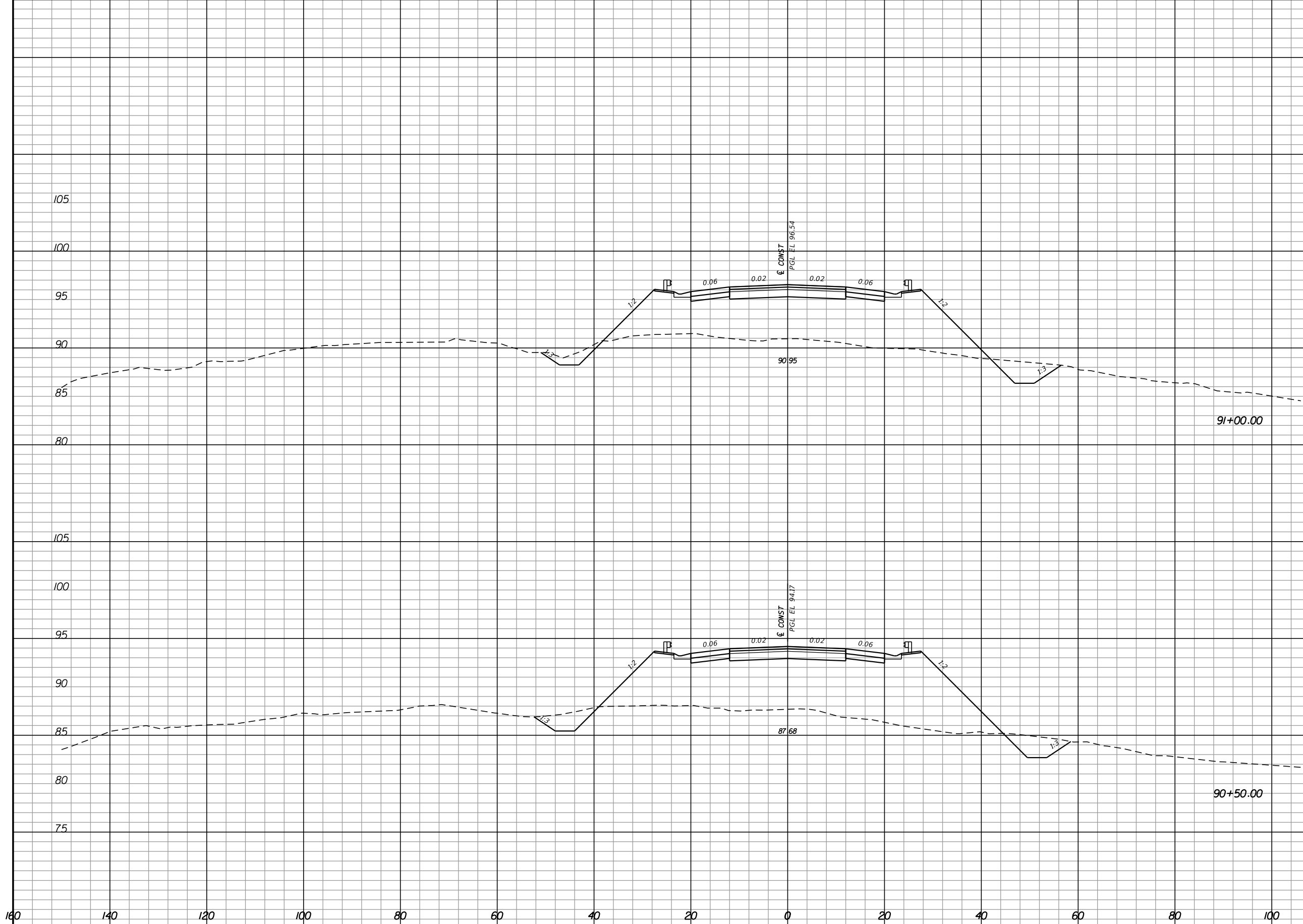

| Regular Exc. |    | Embankment |     |
|--------------|----|------------|-----|
| A            | V  | A          | V   |
| 29.7         |    | 317.1      |     |
|              | 60 |            | 672 |
| 35.4         |    | 408.8      |     |
|              | 70 |            | 773 |

| REVISIONS |             |      |             |
|-----------|-------------|------|-------------|
| DATE      | DESCRIPTION | DATE | DESCRIPTION |
|           |             |      |             |

**Hatch Mott MacDonald**  
 Post Office Box 2518 Pensacola, Florida 32513  
 (850) 484-6011 - Certificate of Authorization #00000155  
 Engineer of Record: David D. Skipper, P.E. #58972

|  |          |                      |
|--|----------|----------------------|
| STATE OF FLORIDA<br>DEPARTMENT OF TRANSPORTATION |          |                      |
| ROAD NO.   | COUNTY   | FINANCIAL PROJECT ID |
|  | ESCAMBIA | 430002-1-52-01       |

**CROSS SECTIONS**

SHEET NO.



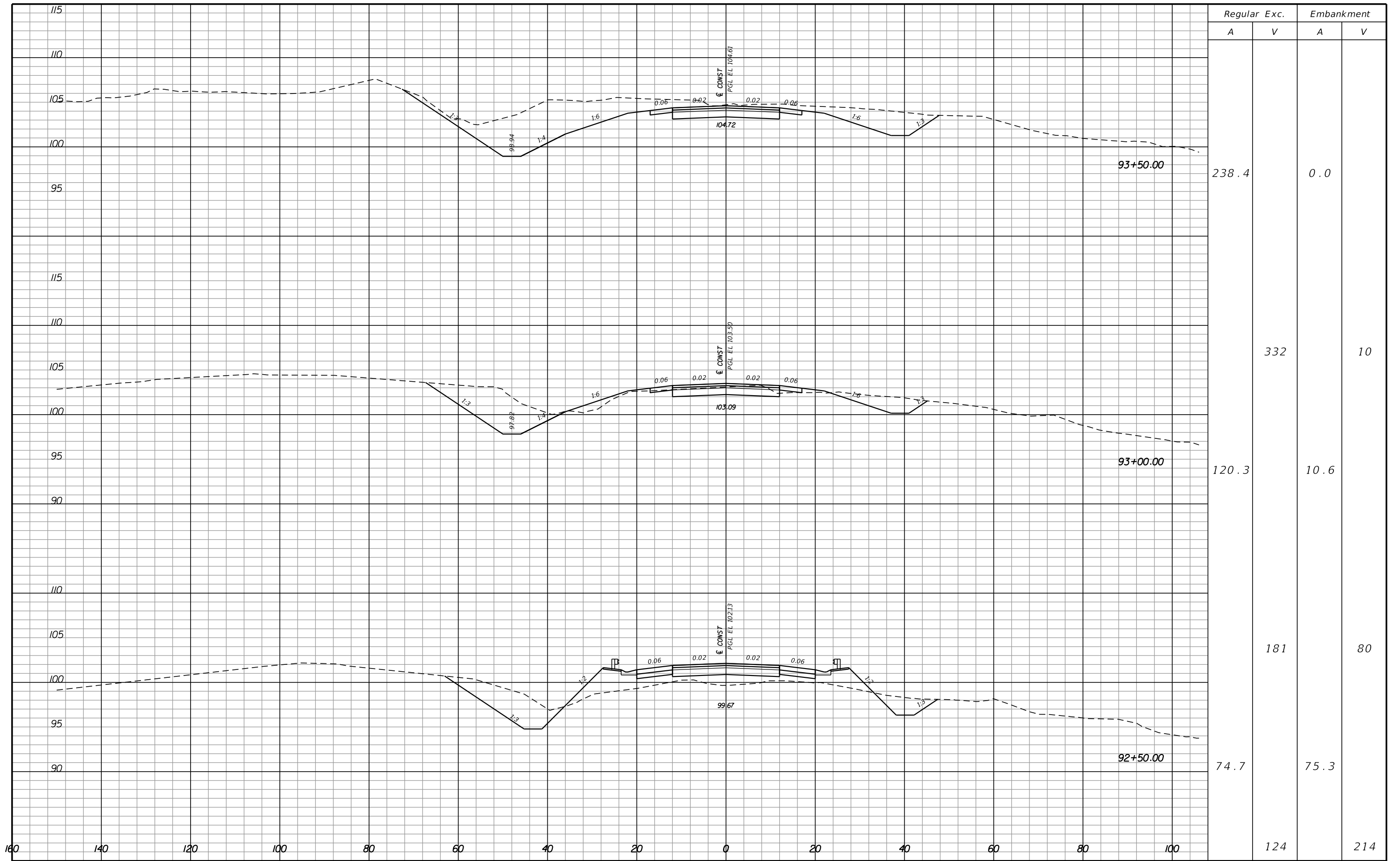

| REVISIONS |             |      |             |
|-----------|-------------|------|-------------|
| DATE      | DESCRIPTION | DATE | DESCRIPTION |
|           |             |      |             |

**Hatch Mott MacDonald**  
 Post Office Box 2518 Pensacola, Florida 32513  
 (850) 484-6011 - Certificate of Authorization #00000155  
 Engineer of Record: David D. Skipper, P.E. #58972

|  |          |                      |
|--|----------|----------------------|
| STATE OF FLORIDA<br>DEPARTMENT OF TRANSPORTATION |          |                      |
| ROAD NO.   | COUNTY   | FINANCIAL PROJECT ID |
|  | ESCAMBIA | 430002-1-52-01       |

**CROSS SECTIONS**

SHEET NO.

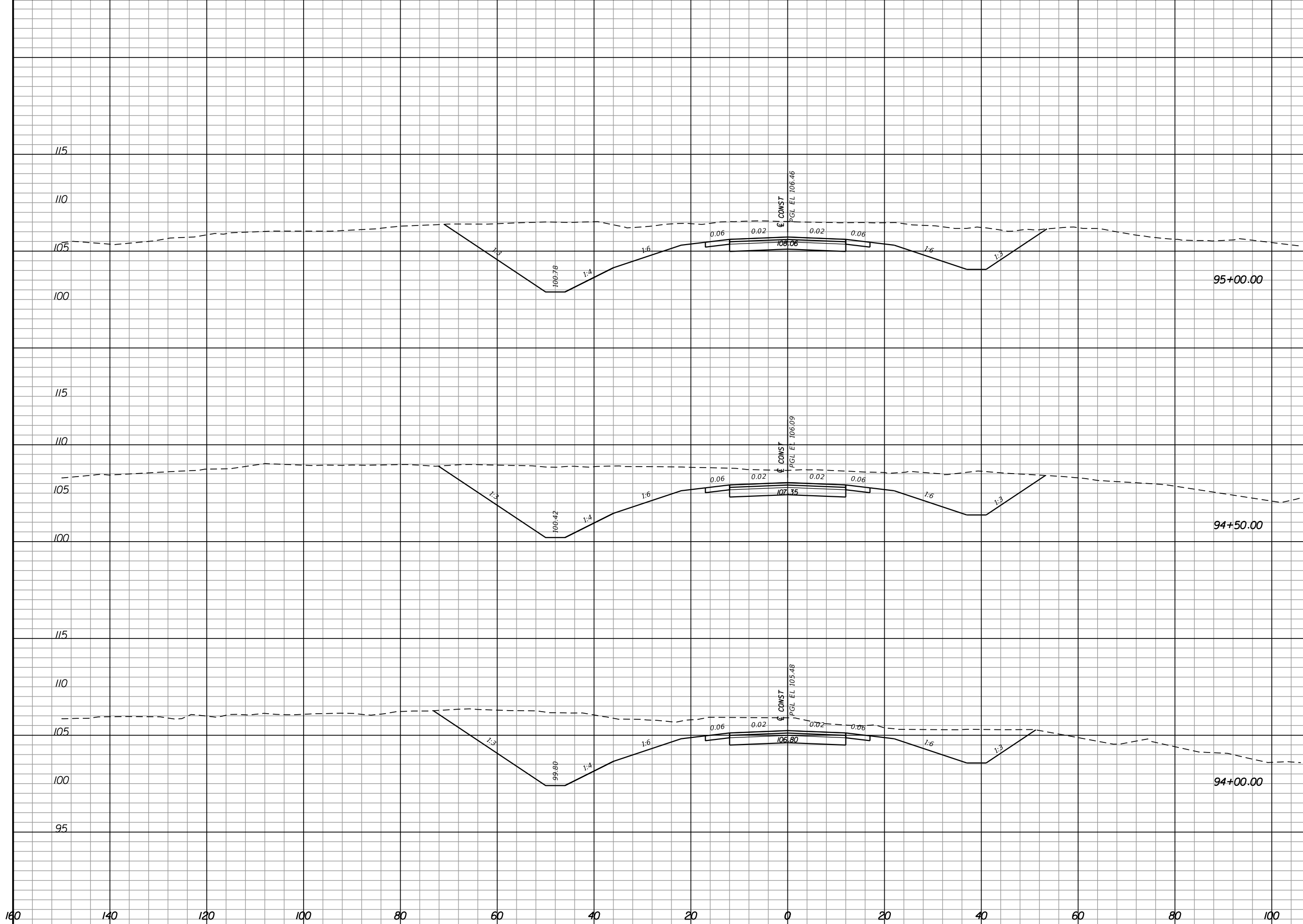

| Regular Exc. |     | Embankment |     |
|--------------|-----|------------|-----|
| A            | V   | A          | V   |
| 414.2        | 0.0 | 0.0        | 0.0 |
| 422.8        | 775 | 0.0        | 0   |
| 382.6        | 746 | 0.0        | 0   |
| 575          | 0   | 0          | 0   |

| REVISIONS |             |      |             |
|-----------|-------------|------|-------------|
| DATE      | DESCRIPTION | DATE | DESCRIPTION |
|           |             |      |             |

Post Office Box 2518 Pensacola, Florida 32513  
 (850) 484-6011 - Certificate of Authorization #00000155  
 Engineer of Record: David D. Skipper, P.E. #58972

|  |          |                      |
|--|----------|----------------------|
| STATE OF FLORIDA<br>DEPARTMENT OF TRANSPORTATION |          |                      |
| ROAD NO.   | COUNTY   | FINANCIAL PROJECT ID |
|  | ESCAMBIA | 430002-1-52-01       |

**CROSS SECTIONS**

SHEET NO.



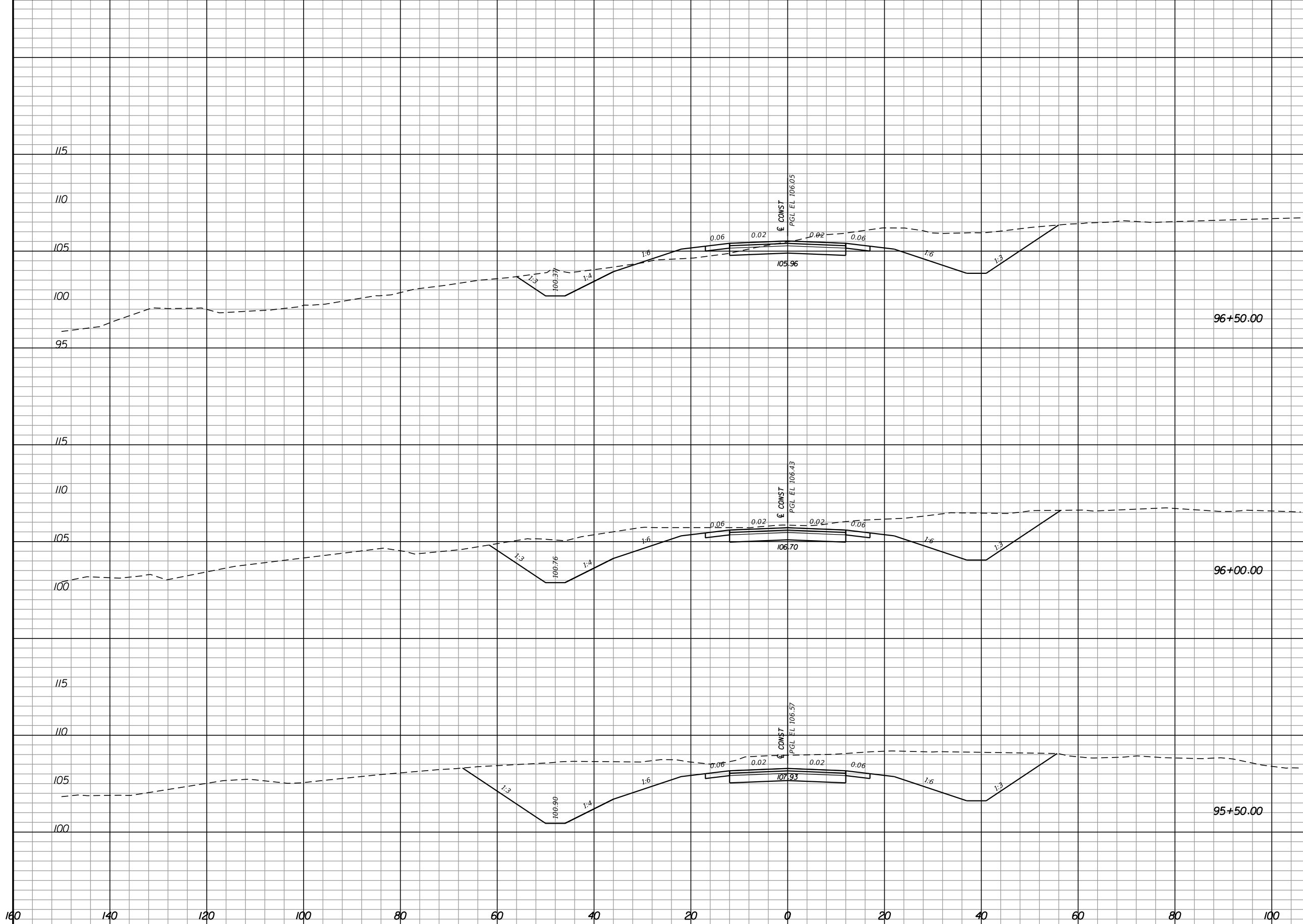

| Regular Exc. |     | Embankment |    |
|--------------|-----|------------|----|
| A            | V   | A          | V  |
| 177.7        |     | 11.7       |    |
| 277.4        | 421 | 0.0        | 11 |
| 386.7        | 615 | 0.0        | 0  |
| 742          |     | 0          |    |

| REVISIONS |             |      |             |
|-----------|-------------|------|-------------|
| DATE      | DESCRIPTION | DATE | DESCRIPTION |
|           |             |      |             |

**Hatch Mott MacDonald**  
 Post Office Box 2518 Pensacola, Florida 32513  
 (850) 484-6011 - Certificate of Authorization #00000155  
 Engineer of Record: David D. Skipper, P.E. #58972

|  |          |                      |
|--|----------|----------------------|
| STATE OF FLORIDA<br>DEPARTMENT OF TRANSPORTATION |          |                      |
| ROAD NO.   | COUNTY   | FINANCIAL PROJECT ID |
|  | ESCAMBIA | 430002-1-52-01       |

**CROSS SECTIONS**

SHEET NO.

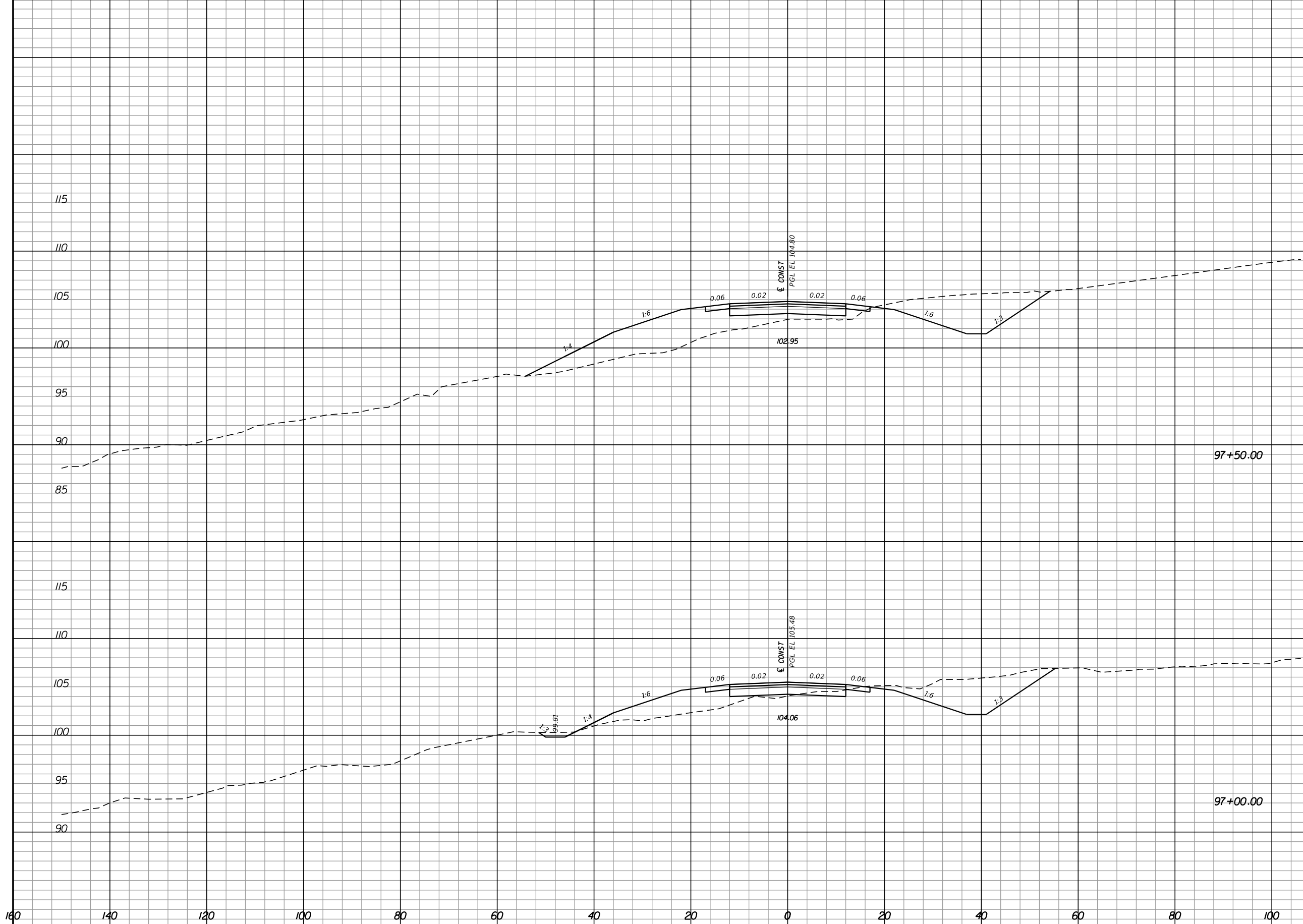

| Regular |     | Exc. |   | Embankment |     |
|---------|-----|------|---|------------|-----|
| A       | V   | A    | V | A          | V   |
| 82.3    |     |      |   | 126.1      |     |
|         |     | 151  |   |            | 166 |
| 81.1    |     |      |   | 53.2       |     |
|         | 240 |      |   |            | 60  |

| REVISIONS |             |      |             |
|-----------|-------------|------|-------------|
| DATE      | DESCRIPTION | DATE | DESCRIPTION |
|           |             |      |             |

**Hatch Mott MacDonald**  
 Post Office Box 2518 Pensacola, Florida 32513  
 (850) 484-6011 - Certificate of Authorization #00000155  
 Engineer of Record: David D. Skipper, P.E. #58972

|  |          |                      |
|--|----------|----------------------|
| STATE OF FLORIDA<br>DEPARTMENT OF TRANSPORTATION |          |                      |
| ROAD NO.   | COUNTY   | FINANCIAL PROJECT ID |
|  | ESCAMBIA | 430002-1-52-01       |

**CROSS SECTIONS**

SHEET NO.

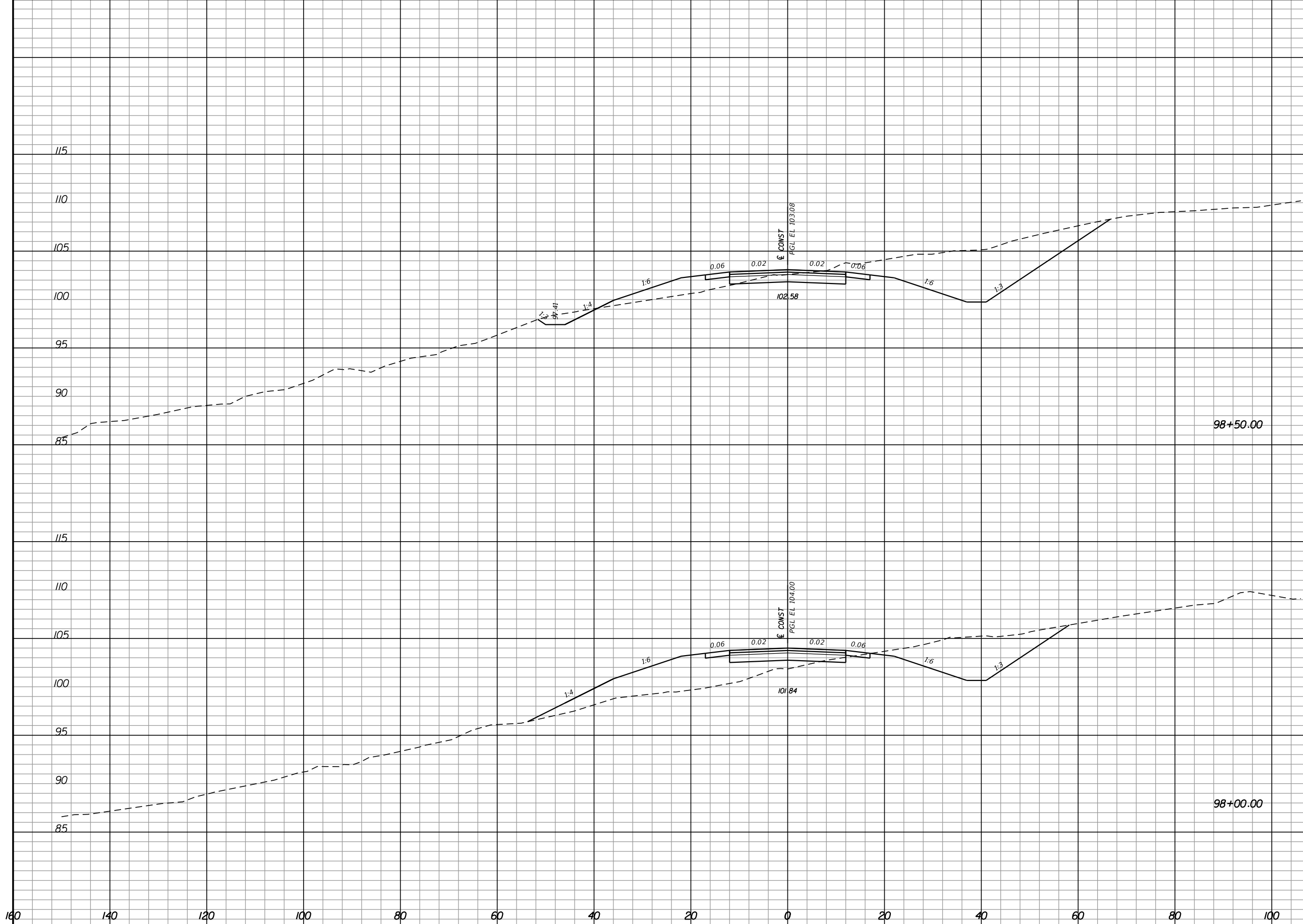

| Regular |     | Exc. |       | Embankment |     |
|---------|-----|------|-------|------------|-----|
| A       | V   | A    | V     | A          | V   |
| 195.8   |     |      | 31.0  |            |     |
|         |     | 272  |       |            | 133 |
| 98.3    |     |      | 112.4 |            |     |
|         | 167 |      |       |            | 221 |

| REVISIONS |             |      |             |
|-----------|-------------|------|-------------|
| DATE      | DESCRIPTION | DATE | DESCRIPTION |
|           |             |      |             |

**Hatch Mott MacDonald**  
 Post Office Box 2518 Pensacola, Florida 32513  
 (850) 484-6011 - Certificate of Authorization #00000155  
 Engineer of Record: David D. Skipper, P.E. #58972

|  |          |                      |
|--|----------|----------------------|
| STATE OF FLORIDA<br>DEPARTMENT OF TRANSPORTATION |          |                      |
| ROAD NO.   | COUNTY   | FINANCIAL PROJECT ID |
|  | ESCAMBIA | 430002-1-52-01       |

**CROSS SECTIONS**

SHEET NO.

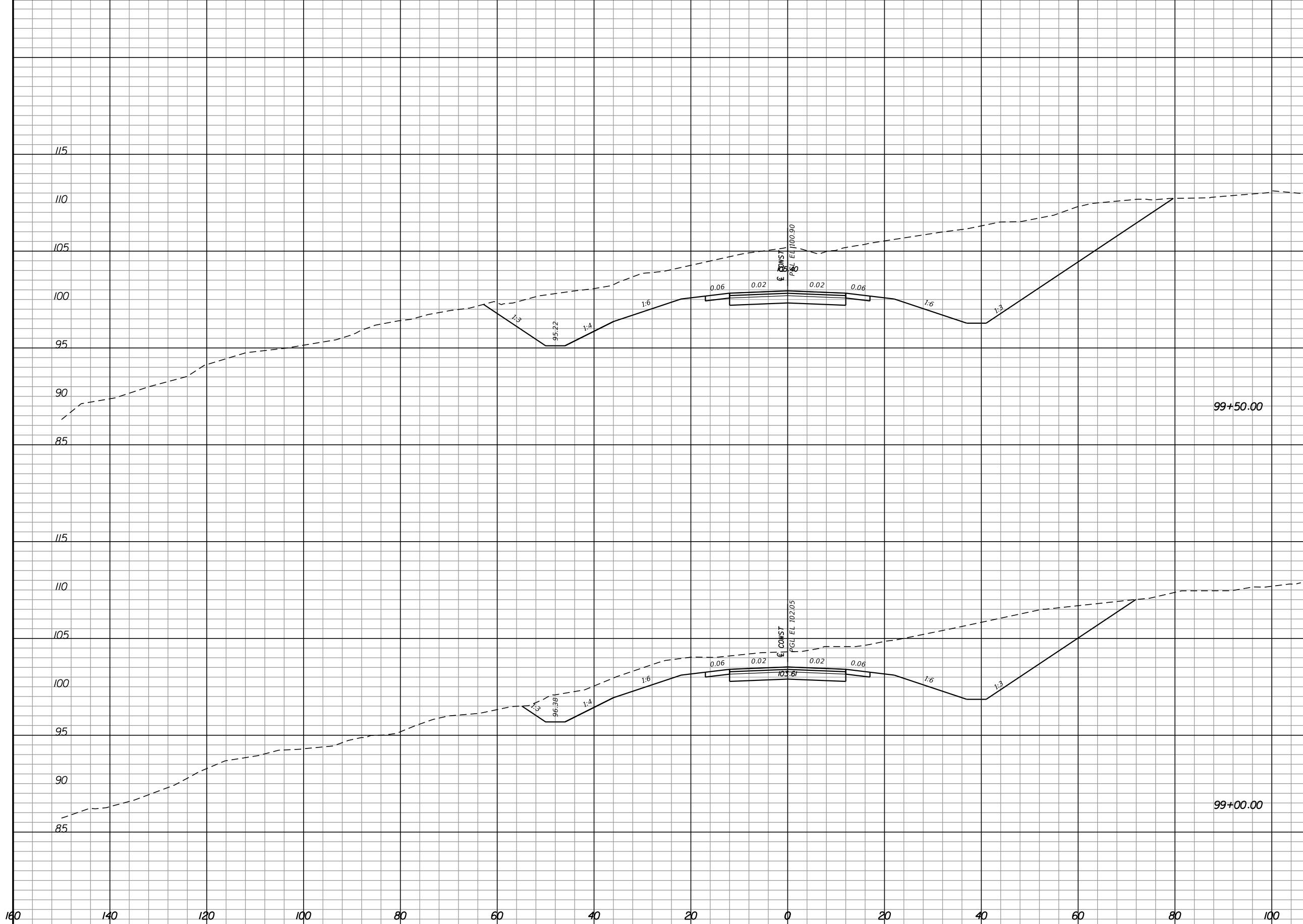

| Station  | Regular Exc. |      | Embankment |     |
|----------|--------------|------|------------|-----|
|          | A            | V    | A          | V   |
| 99+50.00 | 742.9        | 0.0  | 0.0        | 0.0 |
| 99+00.00 | 436.5        | 0.0  | 0.0        | 0.0 |
|          |              | 585  |            | 29  |
|          |              | 1092 |            | 0   |

| REVISIONS |             |      |             |
|-----------|-------------|------|-------------|
| DATE      | DESCRIPTION | DATE | DESCRIPTION |
|           |             |      |             |

**Hatch Mott MacDonald**  
 Post Office Box 2518 Pensacola, Florida 32513  
 (850) 484-6011 - Certificate of Authorization #00000155  
 Engineer of Record: David D. Skipper, P.E. #58972

|  |          |                      |
|--|----------|----------------------|
| STATE OF FLORIDA<br>DEPARTMENT OF TRANSPORTATION |          |                      |
| ROAD NO.   | COUNTY   | FINANCIAL PROJECT ID |
|  | ESCAMBIA | 430002-1-52-01       |

**CROSS SECTIONS**

SHEET NO.













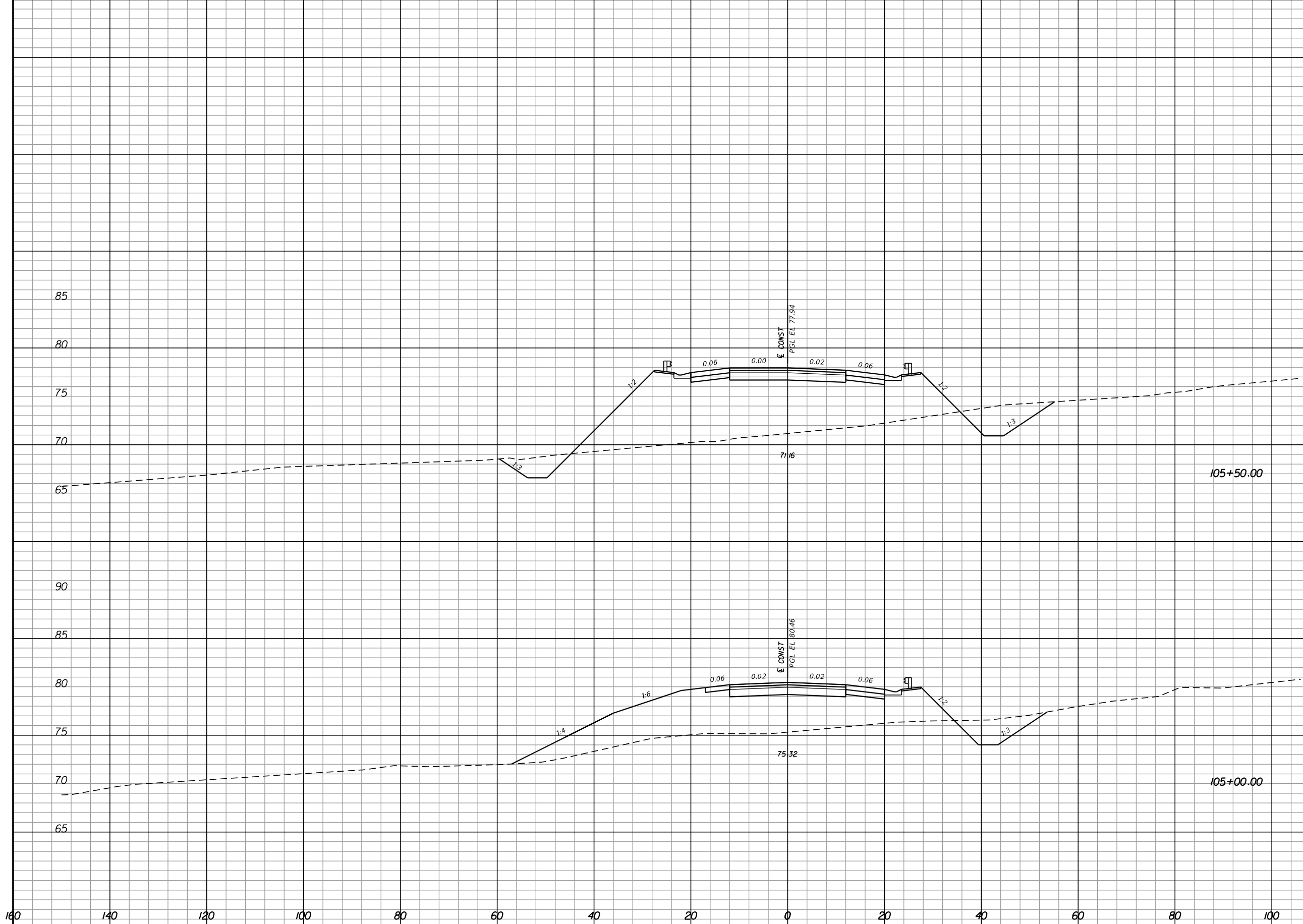

| Regular |     | Exc. |   | Embankment |     |
|---------|-----|------|---|------------|-----|
| A       | V   | A    | V | A          | V   |
| 56.1    |     |      |   | 389.9      |     |
| 29.8    |     |      |   | 289.5      |     |
|         | 149 |      |   |            | 303 |
|         |     | 80   |   |            | 629 |

| REVISIONS |             |      |             |
|-----------|-------------|------|-------------|
| DATE      | DESCRIPTION | DATE | DESCRIPTION |
|           |             |      |             |

**Hatch Mott MacDonald**  
 Post Office Box 2518 Pensacola, Florida 32513  
 (850) 484-6011 - Certificate of Authorization #00000155  
 Engineer of Record: David D. Skipper, P.E. #58972

|  |          |                      |
|--|----------|----------------------|
| STATE OF FLORIDA<br>DEPARTMENT OF TRANSPORTATION |          |                      |
| ROAD NO.   | COUNTY   | FINANCIAL PROJECT ID |
|  | ESCAMBIA | 430002-1-52-01       |

**CROSS SECTIONS**

SHEET NO.

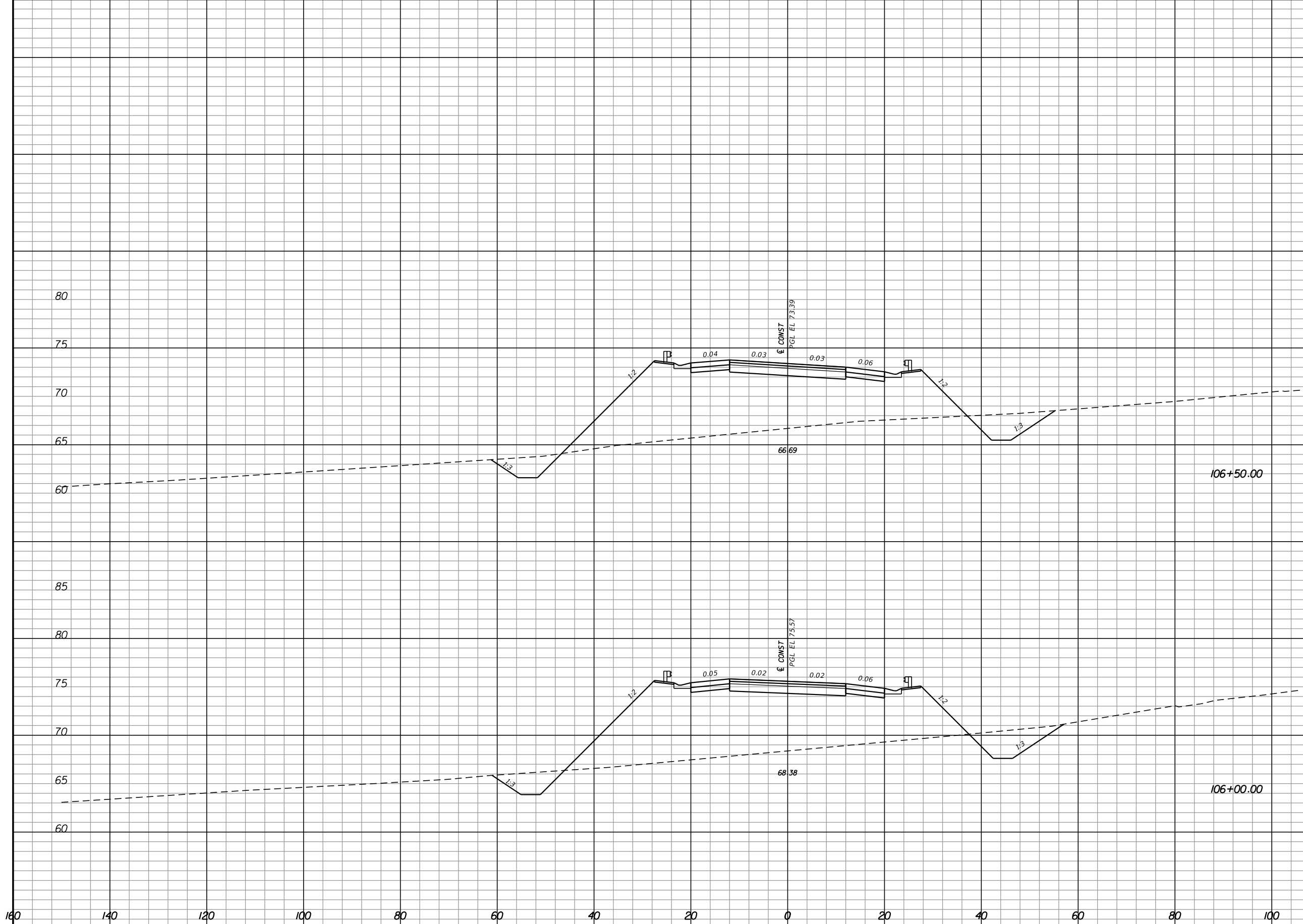

| Regular |     | Exc. |   | Embankment |     |
|---------|-----|------|---|------------|-----|
| A       | V   | A    | V | A          | V   |
| 49.2    |     |      |   | 414.4      |     |
| 54.8    |     |      |   | 442.1      |     |
|         | 103 | 96   |   |            | 770 |
|         |     |      |   |            | 793 |

| REVISIONS |             |      |             |
|-----------|-------------|------|-------------|
| DATE      | DESCRIPTION | DATE | DESCRIPTION |
|           |             |      |             |

**Hatch Mott MacDonald**  
 Post Office Box 2518 Pensacola, Florida 32513  
 (850) 484-6011 - Certificate of Authorization #00000155  
 Engineer of Record: David D. Skipper, P.E. #58972

|  |          |                      |
|--|----------|----------------------|
| STATE OF FLORIDA<br>DEPARTMENT OF TRANSPORTATION |          |                      |
| ROAD NO.   | COUNTY   | FINANCIAL PROJECT ID |
|  | ESCAMBIA | 430002-1-52-01       |

**CROSS SECTIONS**

SHEET NO.

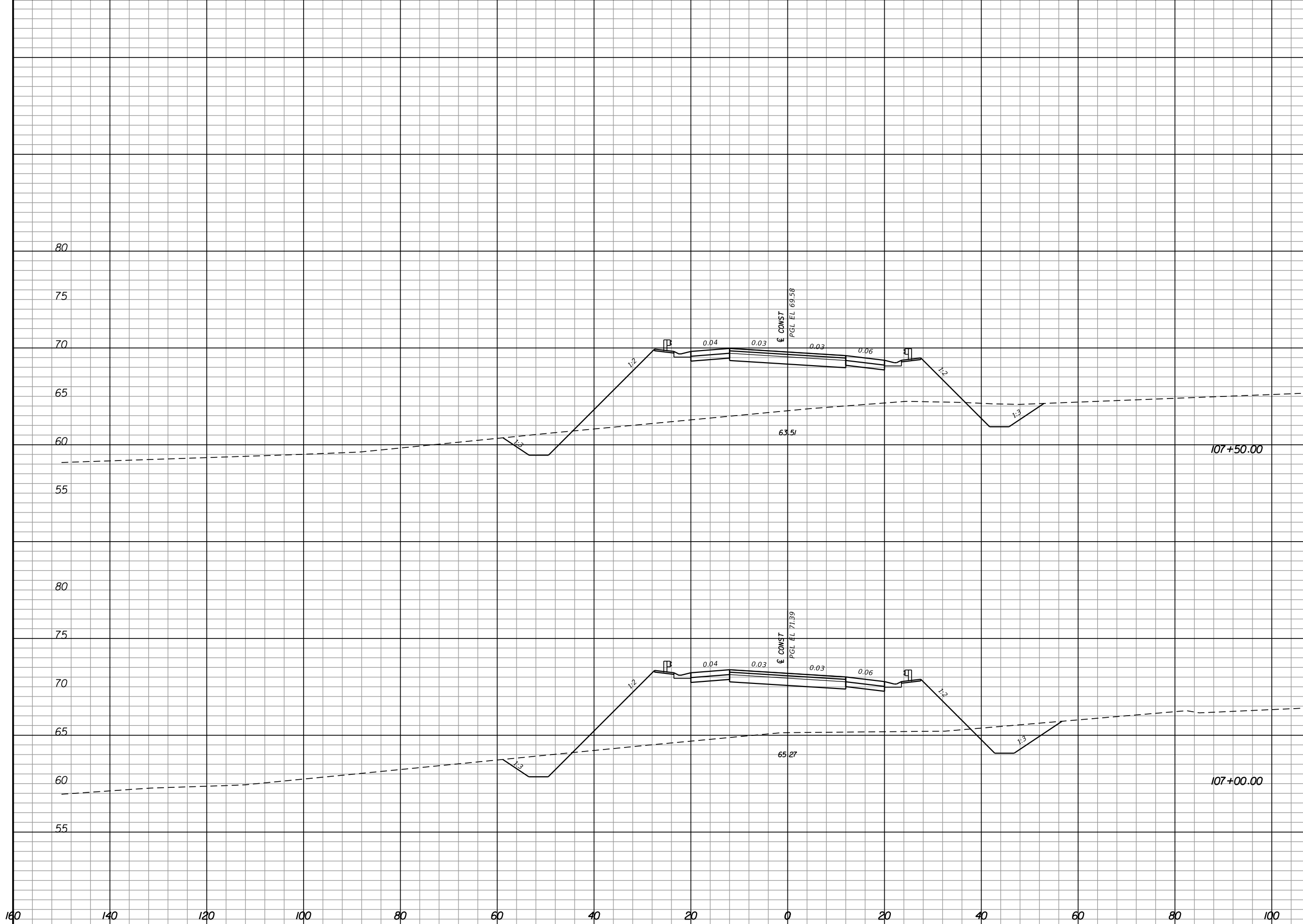

| Regular |    | Exc. |   | Embankment |     |
|---------|----|------|---|------------|-----|
| A       | V  | A    | V | A          | V   |
| 43.5    |    |      |   | 362.1      |     |
| 52.0    | 88 |      |   | 384.7      | 691 |
|         | 94 |      |   |            | 740 |

| REVISIONS |             |      |             |
|-----------|-------------|------|-------------|
| DATE      | DESCRIPTION | DATE | DESCRIPTION |
|           |             |      |             |

**Hatch Mott MacDonald**  
 Post Office Box 2518 Pensacola, Florida 32513  
 (850) 484-6011 - Certificate of Authorization #00000155  
 Engineer of Record: David D. Skipper, P.E. #58972

|  |          |                      |
|--|----------|----------------------|
| STATE OF FLORIDA<br>DEPARTMENT OF TRANSPORTATION |          |                      |
| ROAD NO.   | COUNTY   | FINANCIAL PROJECT ID |
|  | ESCAMBIA | 430002-1-52-01       |

**CROSS SECTIONS**

SHEET NO.



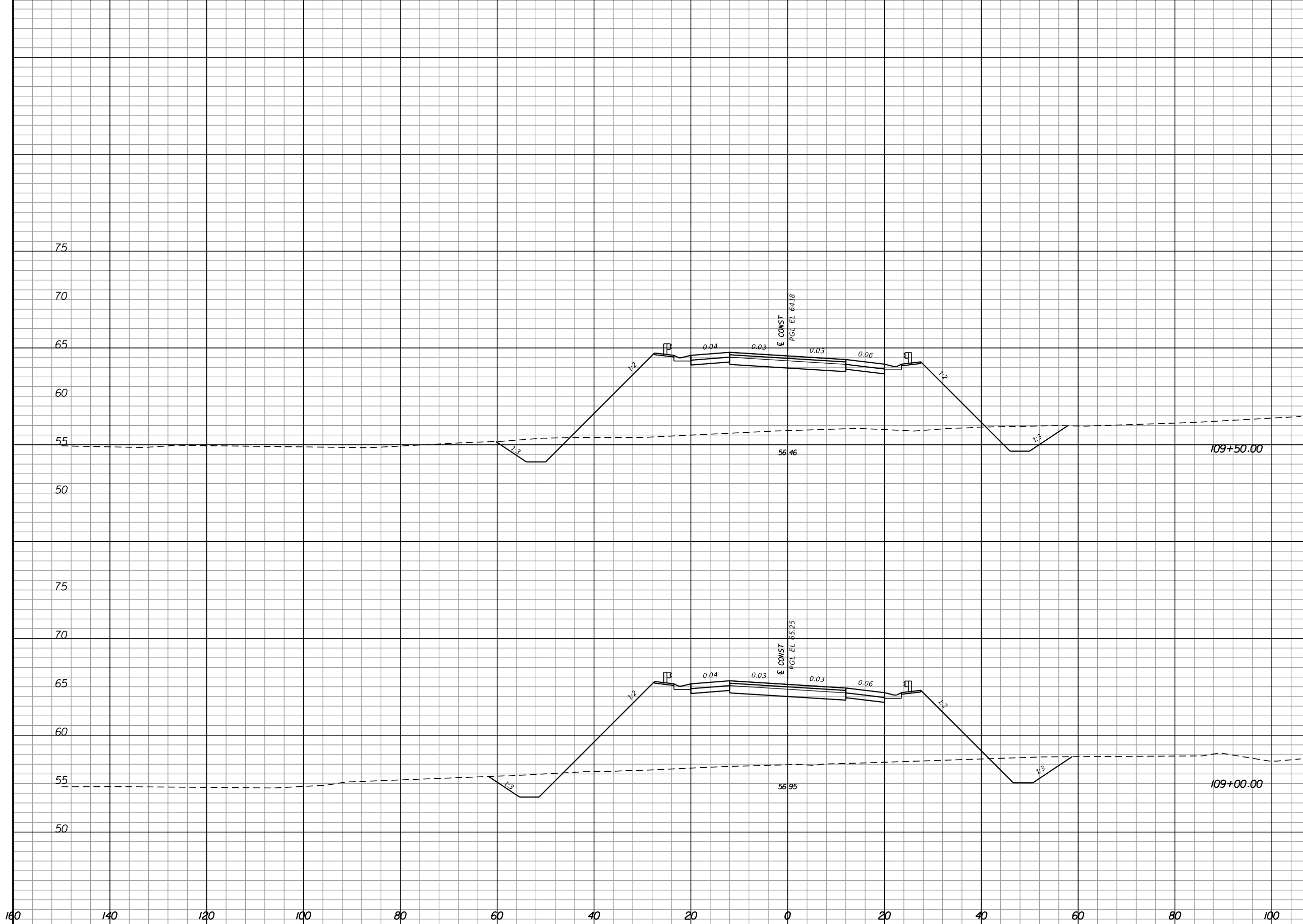

| Regular |    | Exc. |    | Embankment |      |
|---------|----|------|----|------------|------|
| A       | V  | A    | V  | A          | V    |
|         |    |      |    |            |      |
| 49.8    |    |      |    | 494.1      |      |
|         |    |      | 93 |            | 954  |
| 50.1    |    |      |    | 536.0      |      |
|         | 93 |      |    |            | 1011 |

| REVISIONS |             |      |             |
|-----------|-------------|------|-------------|
| DATE      | DESCRIPTION | DATE | DESCRIPTION |
|           |             |      |             |

**Hatch Mott MacDonald**  
 Post Office Box 2518 Pensacola, Florida 32513  
 (850) 484-6011 - Certificate of Authorization #00000155  
 Engineer of Record: David D. Skipper, P.E. #58972

STATE OF FLORIDA  
 DEPARTMENT OF TRANSPORTATION

| ROAD NO. | COUNTY   | FINANCIAL PROJECT ID |
|----------|----------|----------------------|
|          | ESCAMBIA | 430002-1-52-01       |

**CROSS SECTIONS**

|           |
|-----------|
| SHEET NO. |
|-----------|

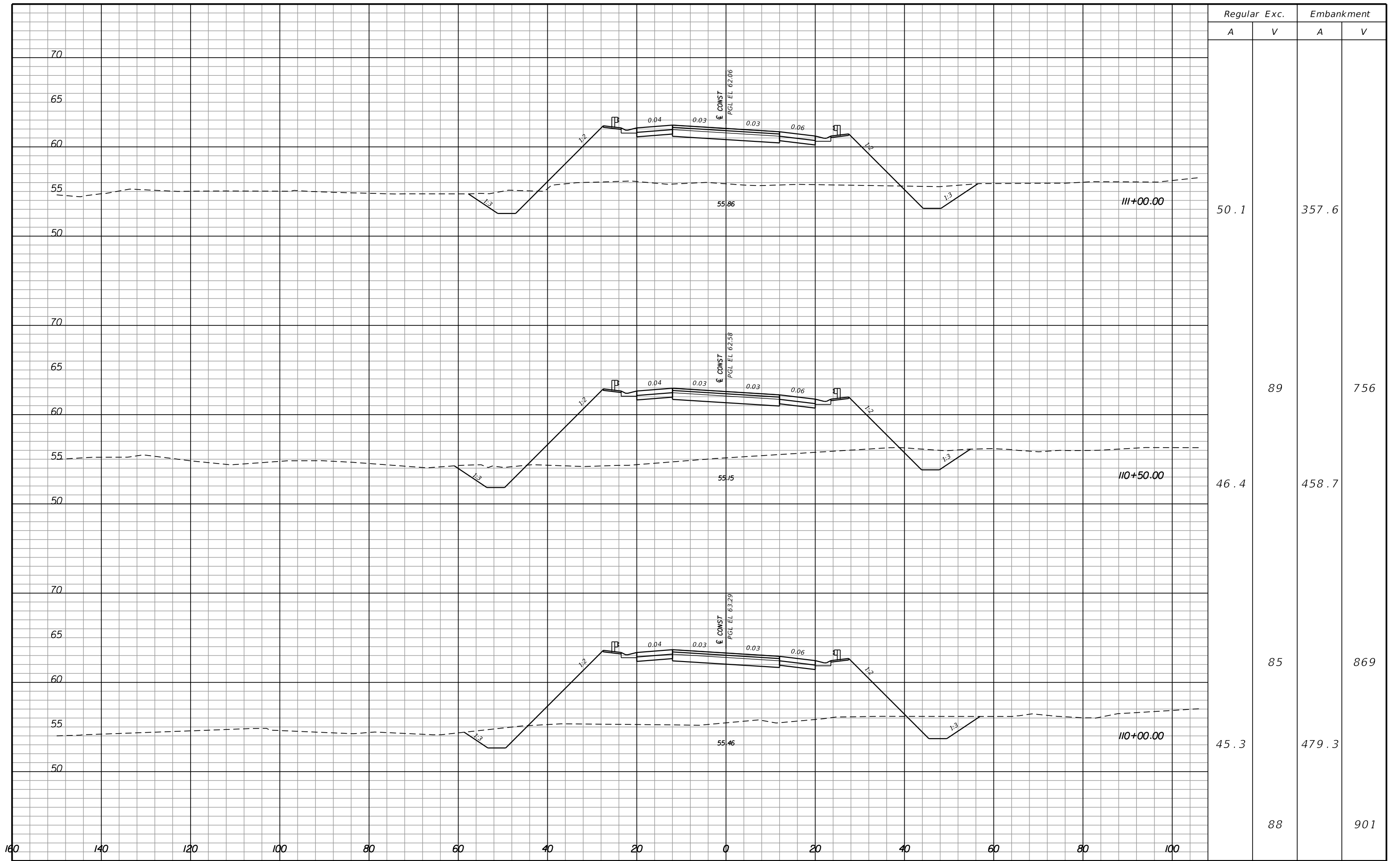

| Regular |    | Exc. |   | Embankment |     |
|---------|----|------|---|------------|-----|
| A       | V  | A    | V | A          | V   |
| 50.1    |    |      |   | 357.6      |     |
| 46.4    | 89 |      |   | 458.7      | 756 |
| 45.3    | 85 |      |   | 479.3      | 869 |
|         | 88 |      |   |            | 901 |

| REVISIONS |             |      |             |
|-----------|-------------|------|-------------|
| DATE      | DESCRIPTION | DATE | DESCRIPTION |
|           |             |      |             |

**Hatch Mott MacDonald**  
 Post Office Box 2518 Pensacola, Florida 32513  
 (850) 484-6011 - Certificate of Authorization #00000155  
 Engineer of Record: David D. Skipper, P.E. #58972

|  |          |                      |
|--|----------|----------------------|
| STATE OF FLORIDA<br>DEPARTMENT OF TRANSPORTATION |          |                      |
| ROAD NO.   | COUNTY   | FINANCIAL PROJECT ID |
|  | ESCAMBIA | 430002-1-52-01       |

**CROSS SECTIONS**

SHEET NO.

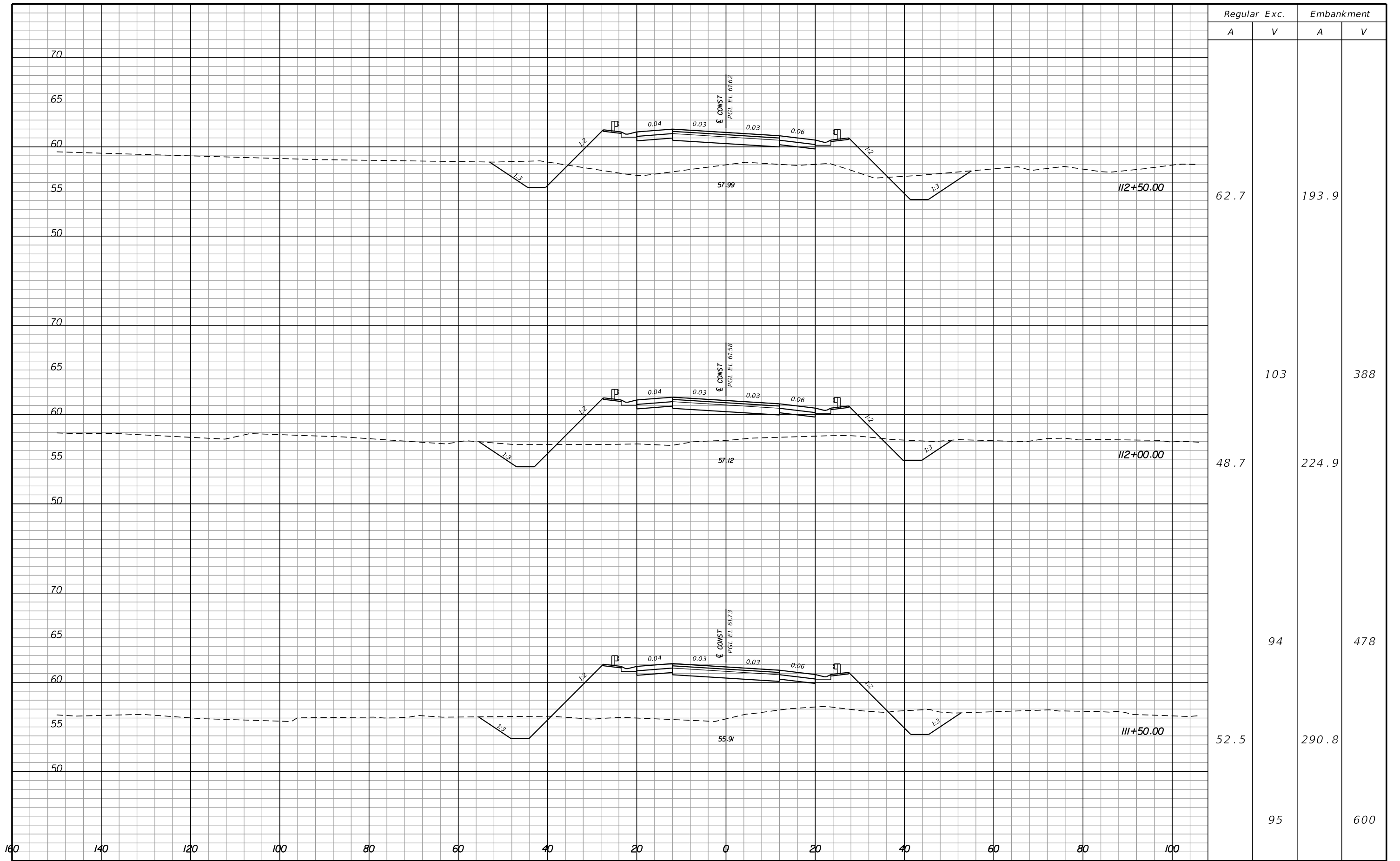

| Regular |     | Exc.  |   | Embankment |   |
|---------|-----|-------|---|------------|---|
| A       | V   | A     | V | A          | V |
| 62.7    |     |       |   | 193.9      |   |
| 48.7    | 103 | 224.9 |   | 388        |   |
| 52.5    | 94  | 290.8 |   | 478        |   |
|         | 95  |       |   | 600        |   |

| REVISIONS |             |      |             |
|-----------|-------------|------|-------------|
| DATE      | DESCRIPTION | DATE | DESCRIPTION |
|           |             |      |             |

**Hatch Mott MacDonald**  
 Post Office Box 2518 Pensacola, Florida 32513  
 (850) 484-6011 - Certificate of Authorization #00000155  
 Engineer of Record: David D. Skipper, P.E. #58972

STATE OF FLORIDA  
 DEPARTMENT OF TRANSPORTATION

| ROAD NO. | COUNTY   | FINANCIAL PROJECT ID |
|----------|----------|----------------------|
|          | ESCAMBIA | 430002-1-52-01       |

**CROSS SECTIONS**

SHEET NO.



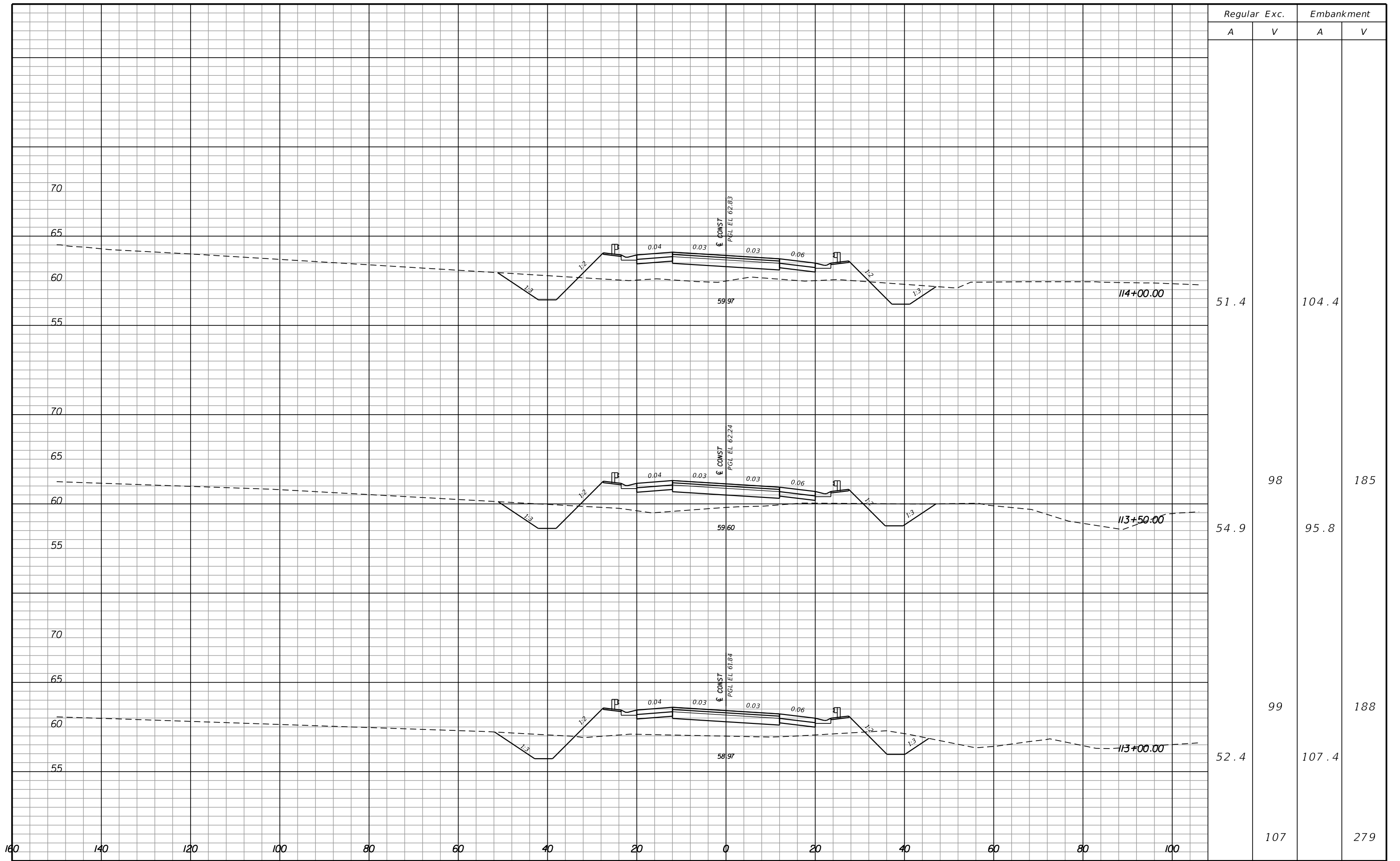

| REVISIONS |             |      |             |
|-----------|-------------|------|-------------|
| DATE      | DESCRIPTION | DATE | DESCRIPTION |
|           |             |      |             |

**Hatch Mott MacDonald**  
 Post Office Box 2518 Pensacola, Florida 32513  
 (850) 484-6011 - Certificate of Authorization #00000155  
 Engineer of Record: David D. Skipper, P.E. #58972

STATE OF FLORIDA  
 DEPARTMENT OF TRANSPORTATION

| ROAD NO. | COUNTY   | FINANCIAL PROJECT ID |
|----------|----------|----------------------|
|          | ESCAMBIA | 430002-1-52-01       |

**CROSS SECTIONS**

SHEET NO.

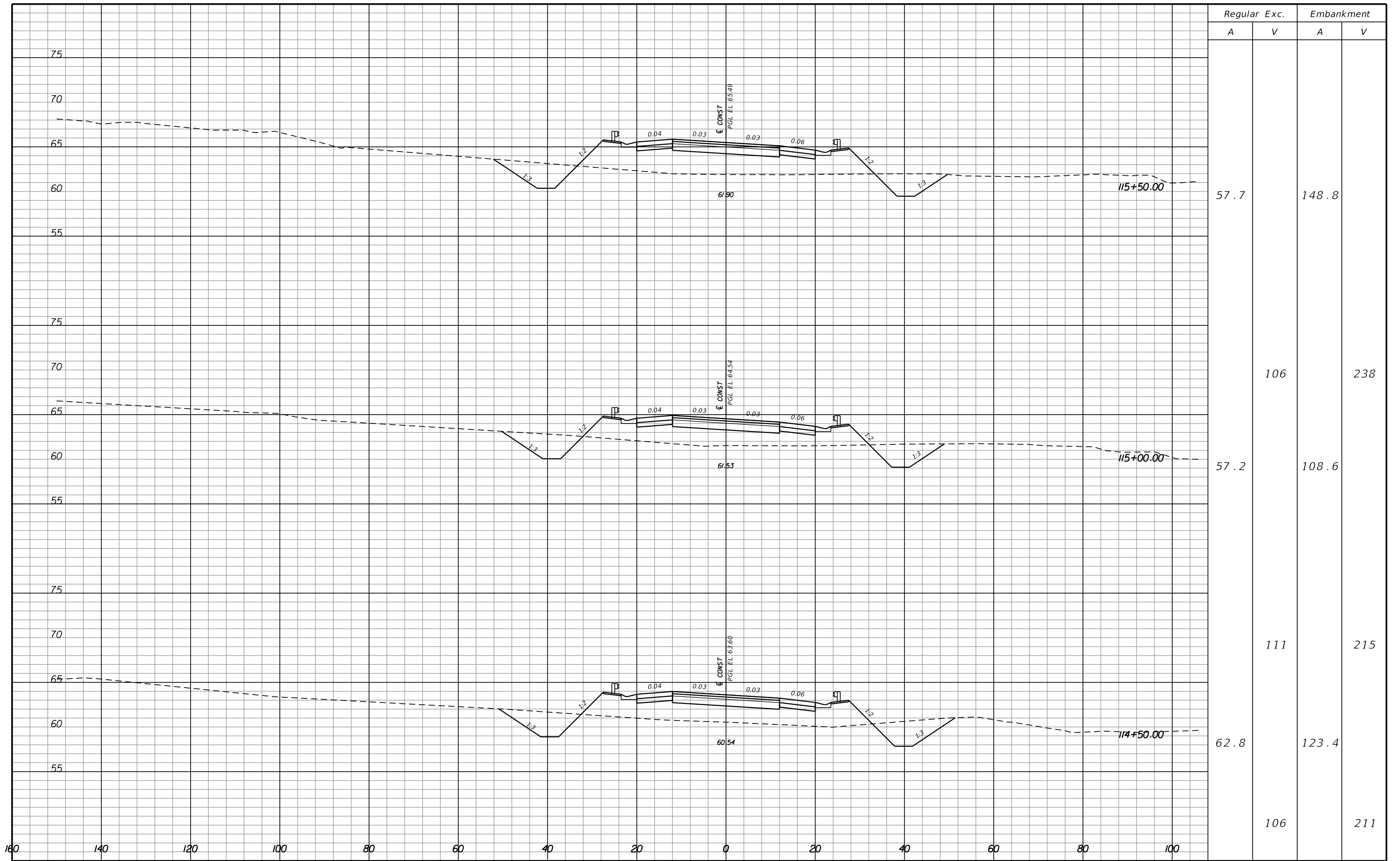

| Regular |     | Exc. |   | Embankment |     |
|---------|-----|------|---|------------|-----|
| A       | V   | A    | V | A          | V   |
| 57.7    |     |      |   | 148.8      |     |
| 57.2    | 106 |      |   | 108.6      | 238 |
| 62.8    |     |      |   | 123.4      | 215 |
|         | 106 |      |   |            | 211 |

| REVISIONS |             |      |             |
|-----------|-------------|------|-------------|
| DATE      | DESCRIPTION | DATE | DESCRIPTION |
|           |             |      |             |

**Hatch Mott MacDonald**  
 Post Office Box 2518 Pensacola, Florida 32513  
 (850) 484-6011 - Certificate of Authorization #00000155  
 Engineer of Record: David D. Skipper, P.E. #58972

|  |          |                      |
|--|----------|----------------------|
| STATE OF FLORIDA<br>DEPARTMENT OF TRANSPORTATION |          |                      |
| ROAD NO.   | COUNTY   | FINANCIAL PROJECT ID |
|  | ESCAMBIA | 430002-1-52-01       |

**CROSS SECTIONS**

|           |
|-----------|
| SHEET NO. |
|           |

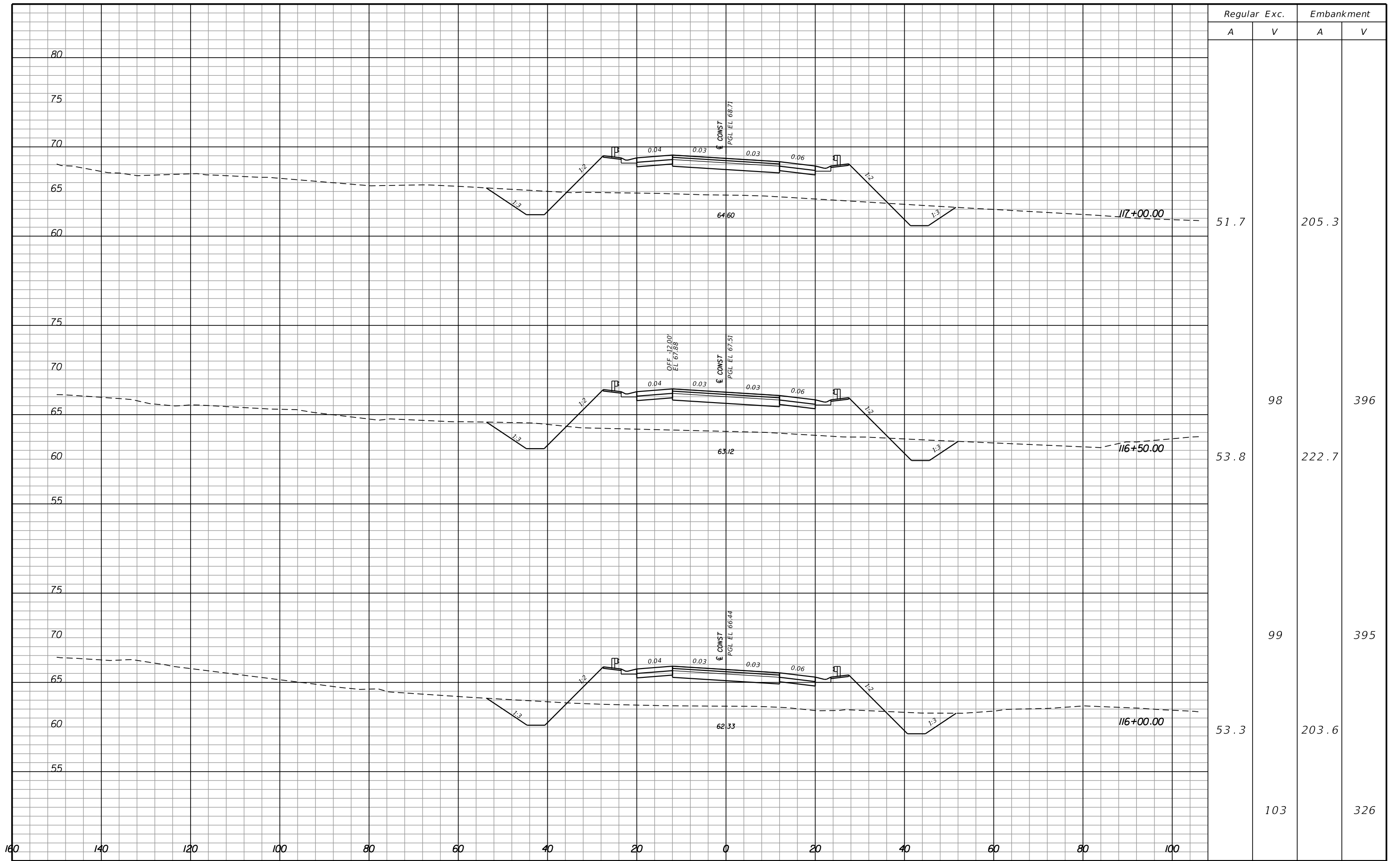

| Regular |     | Exc. |   | Embankment |     |
|---------|-----|------|---|------------|-----|
| A       | V   | A    | V | A          | V   |
| 51.7    |     |      |   | 205.3      |     |
| 53.8    | 98  |      |   | 222.7      | 396 |
| 53.3    | 99  |      |   | 203.6      | 395 |
|         | 103 |      |   |            | 326 |

| REVISIONS |             |      |             |
|-----------|-------------|------|-------------|
| DATE      | DESCRIPTION | DATE | DESCRIPTION |
|           |             |      |             |

**Hatch Mott MacDonald**  
 Post Office Box 2518 Pensacola, Florida 32513  
 (850) 484-6011 - Certificate of Authorization #00000155  
 Engineer of Record: David D. Skipper, P.E. #58972

STATE OF FLORIDA  
 DEPARTMENT OF TRANSPORTATION

| ROAD NO. | COUNTY   | FINANCIAL PROJECT ID |
|----------|----------|----------------------|
|          | ESCAMBIA | 430002-1-52-01       |

**CROSS SECTIONS**

SHEET NO.

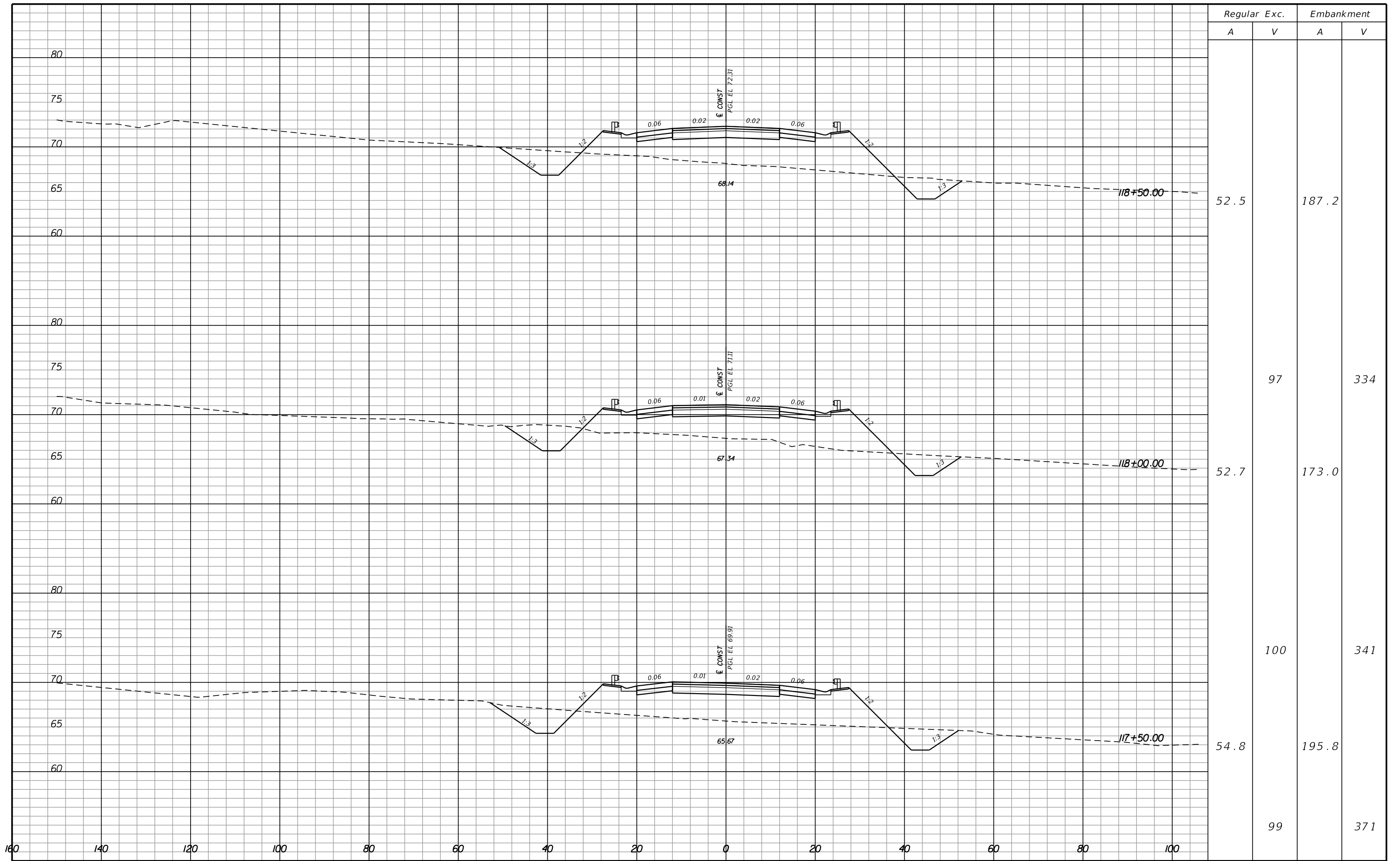

| REVISIONS |             |      |             |
|-----------|-------------|------|-------------|
| DATE      | DESCRIPTION | DATE | DESCRIPTION |
|           |             |      |             |

**Hatch Mott MacDonald**  
 Post Office Box 2518 Pensacola, Florida 32513  
 (850) 484-6011 - Certificate of Authorization #00000155  
 Engineer of Record: David D. Skipper, P.E. #58972

|  |          |                      |
|--|----------|----------------------|
| STATE OF FLORIDA<br>DEPARTMENT OF TRANSPORTATION |          |                      |
| ROAD NO.   | COUNTY   | FINANCIAL PROJECT ID |
|  | ESCAMBIA | 430002-1-52-01       |

CROSS SECTIONS

SHEET NO.

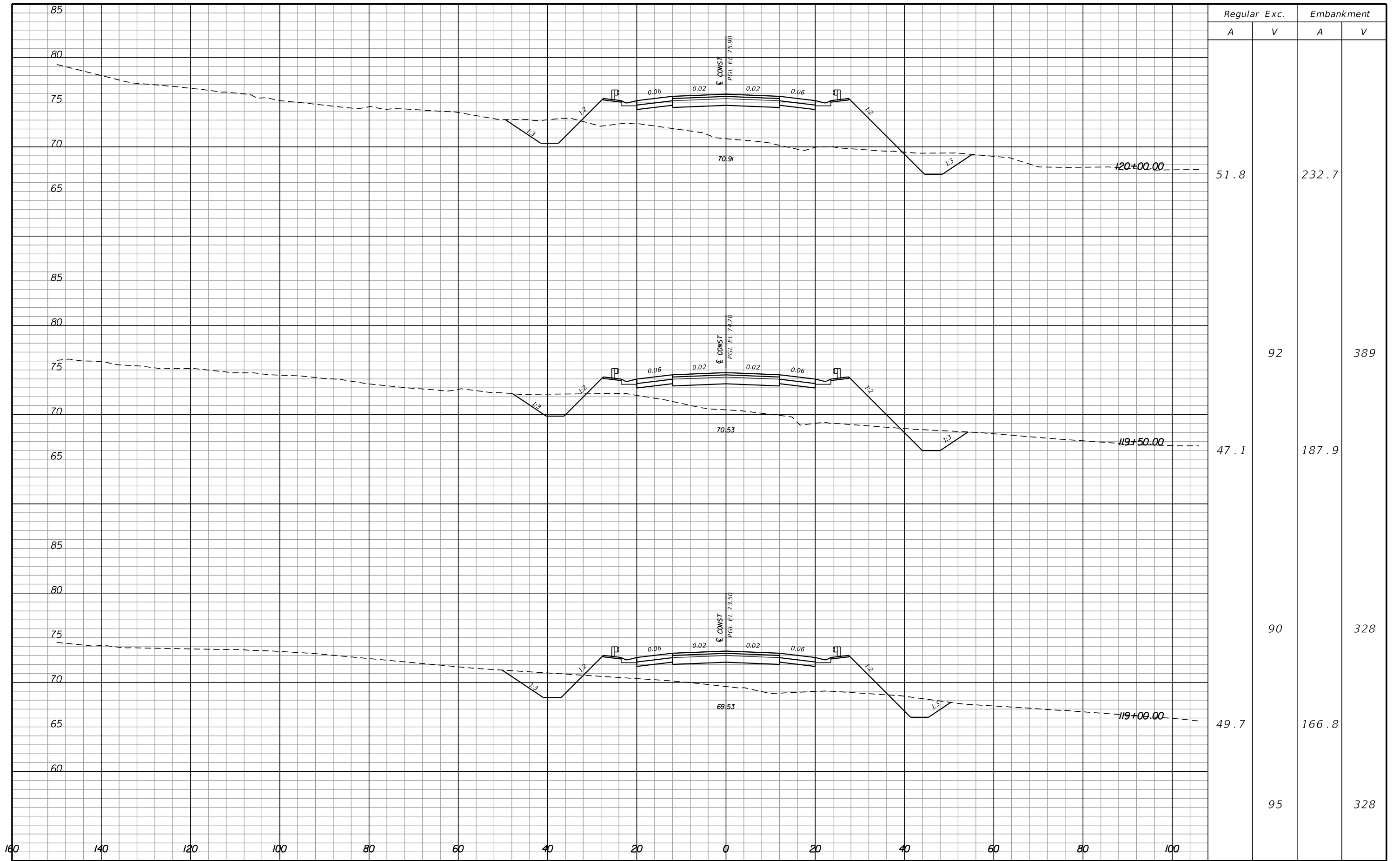

| REVISIONS |             |      |             |
|-----------|-------------|------|-------------|
| DATE      | DESCRIPTION | DATE | DESCRIPTION |
|           |             |      |             |

**Hatch Mott MacDonald**  
 Post Office Box 2518 Pensacola, Florida 32513  
 (850) 484-6011 - Certificate of Authorization #00000155  
 Engineer of Record: David D. Skipper, P.E. #58972

STATE OF FLORIDA  
 DEPARTMENT OF TRANSPORTATION

|          |          |                      |
|----------|----------|----------------------|
| ROAD NO. | COUNTY   | FINANCIAL PROJECT ID |
|          | ESCAMBIA | 430002-1-52-01       |

**CROSS SECTIONS**

SHEET NO.

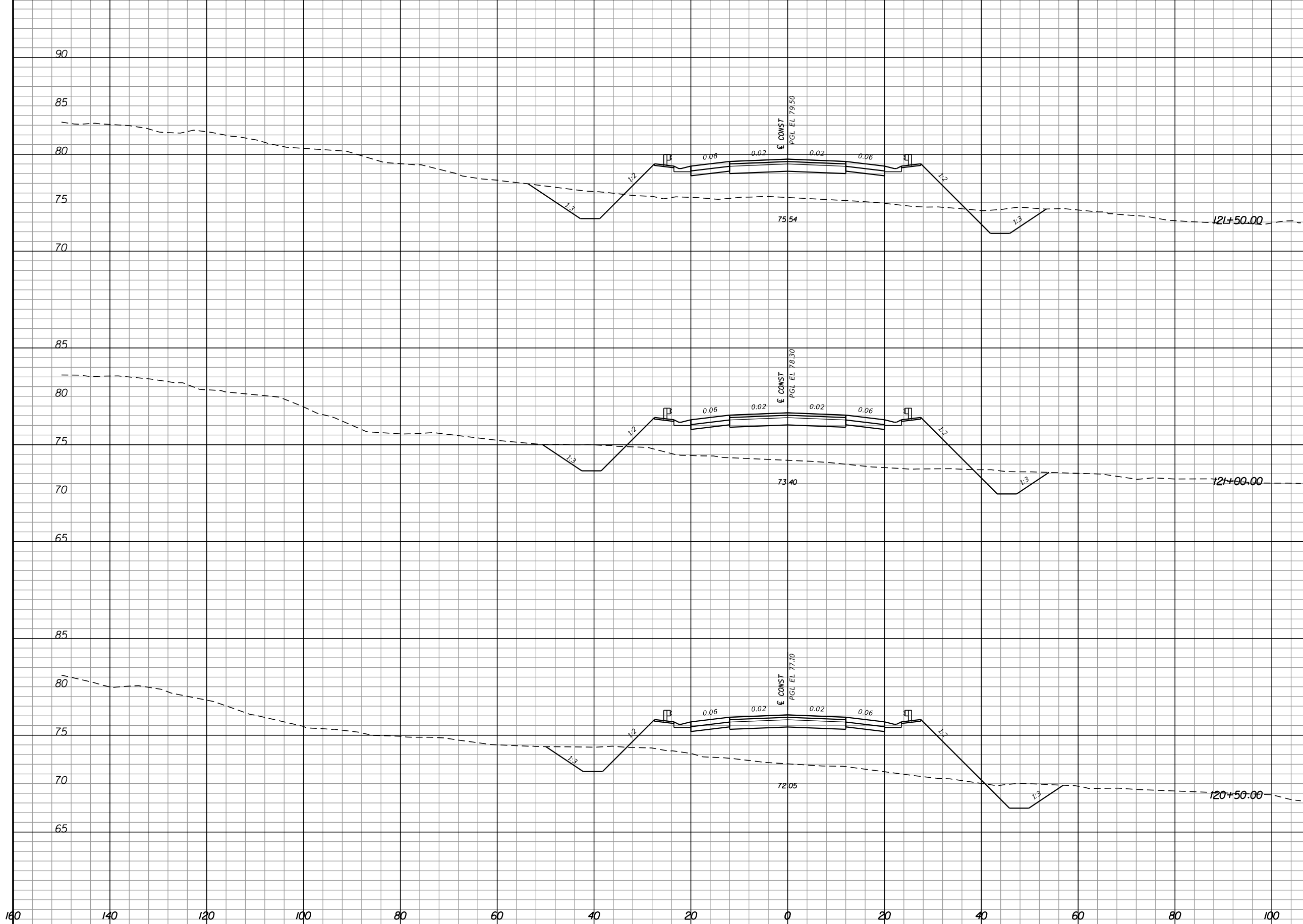

| Regular |     | Exc. |   | Embankment |     |
|---------|-----|------|---|------------|-----|
| A       | V   | A    | V | A          | V   |
| 59.9    |     |      |   | 189.2      |     |
| 51.7    | 103 |      |   | 238.6      | 396 |
| 51.4    | 95  |      |   | 248.8      | 451 |
|         | 96  |      |   |            | 446 |

| REVISIONS |             |      |             |
|-----------|-------------|------|-------------|
| DATE      | DESCRIPTION | DATE | DESCRIPTION |
|           |             |      |             |

**Hatch Mott MacDonald**  
 Post Office Box 2518 Pensacola, Florida 32513  
 (850) 484-6011 - Certificate of Authorization #00000155  
 Engineer of Record: David D. Skipper, P.E. #58972

|  |          |                      |
|--|----------|----------------------|
| STATE OF FLORIDA<br>DEPARTMENT OF TRANSPORTATION |          |                      |
| ROAD NO.   | COUNTY   | FINANCIAL PROJECT ID |
|  | ESCAMBIA | 430002-1-52-01       |

**CROSS SECTIONS**

SHEET NO.

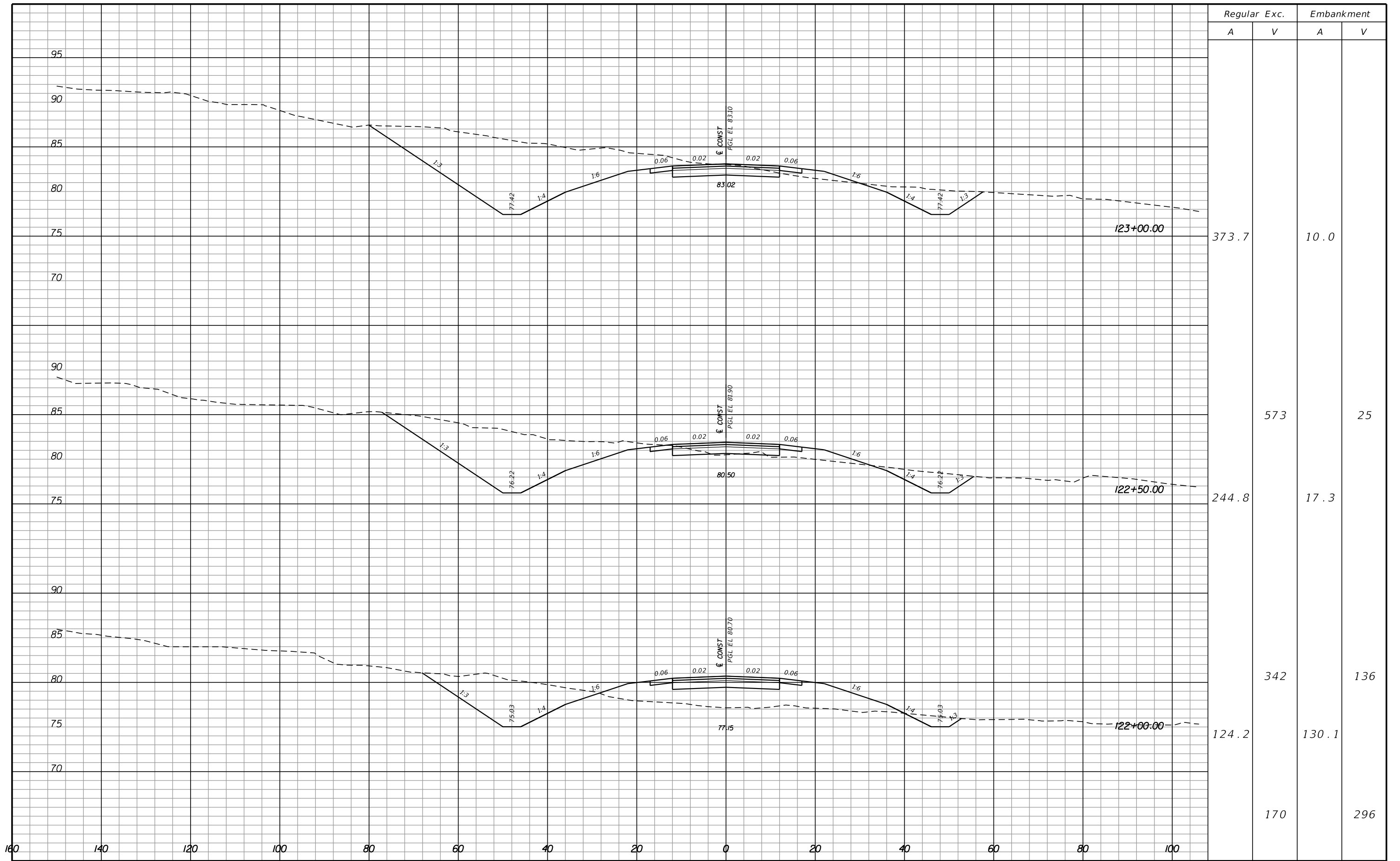

| Regular |       | Exc. |     |
|---------|-------|------|-----|
| A       | V     | A    | V   |
| 373.7   | 10.0  |      |     |
|         | 573   |      | 25  |
| 244.8   | 17.3  |      |     |
|         | 342   |      | 136 |
| 124.2   | 130.1 |      |     |
|         | 170   |      | 296 |

| REVISIONS |             |      |             |
|-----------|-------------|------|-------------|
| DATE      | DESCRIPTION | DATE | DESCRIPTION |
|           |             |      |             |

**Hatch Mott MacDonald**  
 Post Office Box 2518 Pensacola, Florida 32513  
 (850) 484-6011 - Certificate of Authorization #00000155  
 Engineer of Record: David D. Skipper, P.E. #58972

STATE OF FLORIDA  
 DEPARTMENT OF TRANSPORTATION

|          |          |                      |
|----------|----------|----------------------|
| ROAD NO. | COUNTY   | FINANCIAL PROJECT ID |
|          | ESCAMBIA | 430002-1-52-01       |

*CROSS SECTIONS*

|           |
|-----------|
| SHEET NO. |
|-----------|

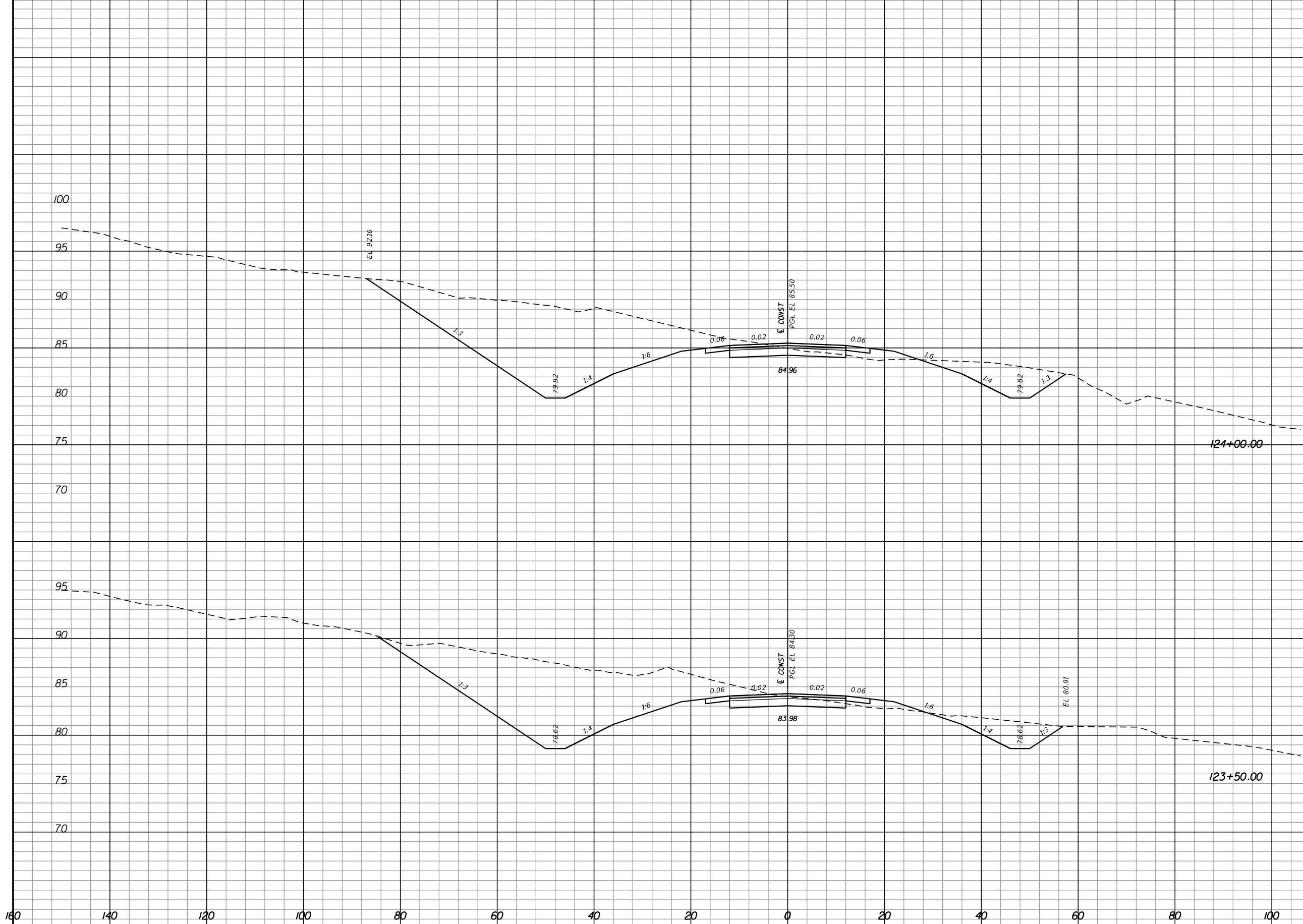

| Regular |   | Exc. |      | Embankment |    |
|---------|---|------|------|------------|----|
| A       | V | A    | V    | A          | V  |
| 444.6   |   |      | 10.1 |            |    |
|         |   | 794  |      |            | 17 |
| 413.1   |   |      | 7.9  |            |    |
|         |   | 729  |      |            | 17 |

| REVISIONS |             |      |             |
|-----------|-------------|------|-------------|
| DATE      | DESCRIPTION | DATE | DESCRIPTION |
|           |             |      |             |

**Hatch Mott MacDonald**  
 Post Office Box 2518 Pensacola, Florida 32513  
 (850) 484-6011 - Certificate of Authorization #00000155  
 Engineer of Record: David D. Skipper, P.E. #58972

|  |          |                      |
|--|----------|----------------------|
| STATE OF FLORIDA<br>DEPARTMENT OF TRANSPORTATION |          |                      |
| ROAD NO.   | COUNTY   | FINANCIAL PROJECT ID |
|  | ESCAMBIA | 430002-1-52-01       |

**CROSS SECTIONS**

SHEET NO.



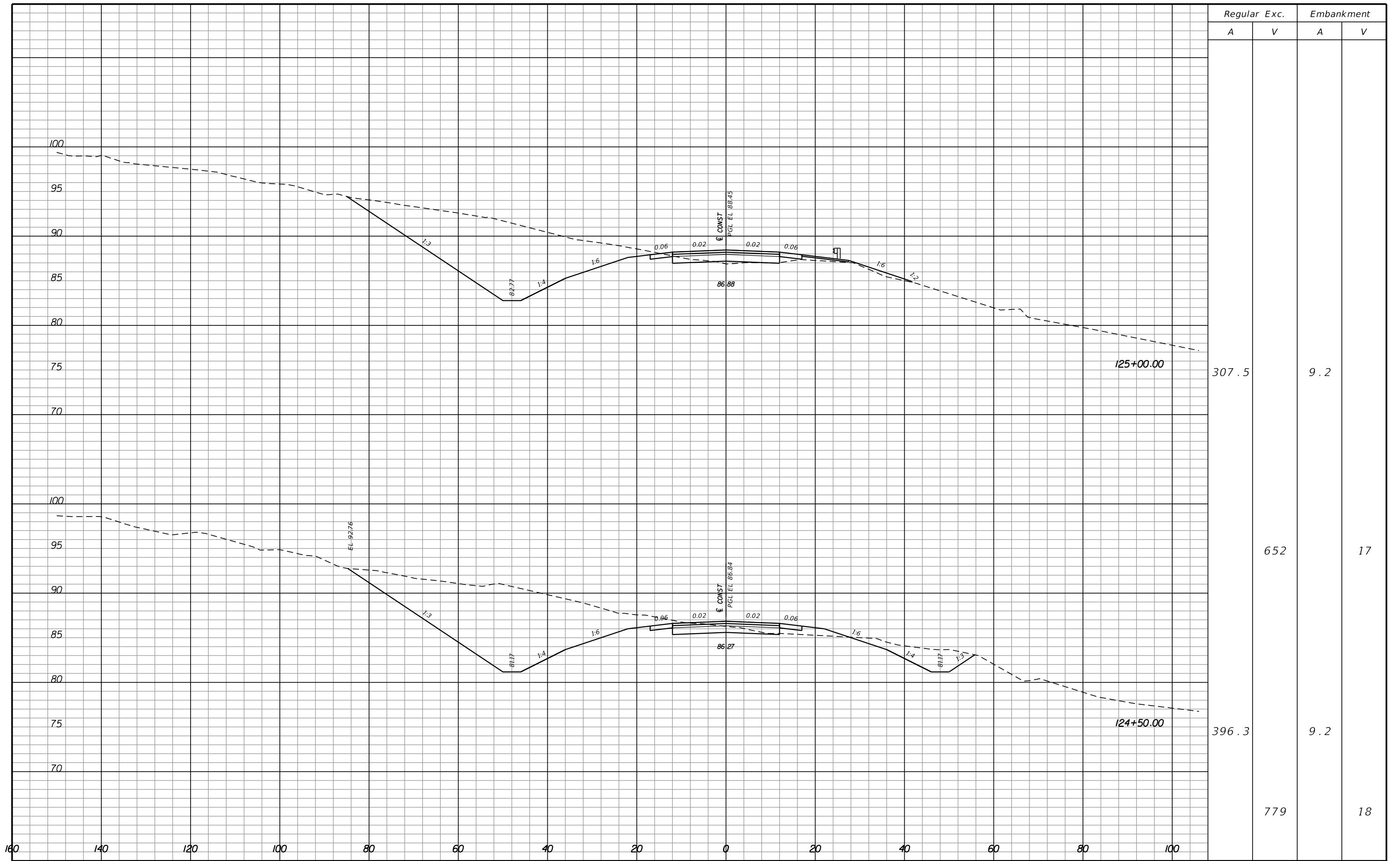

| REVISIONS |             |      |             |
|-----------|-------------|------|-------------|
| DATE      | DESCRIPTION | DATE | DESCRIPTION |
|           |             |      |             |



**Hatch Mott MacDonald**  
 Post Office Box 2518 Pensacola, Florida 32513  
 (850) 484-6011 - Certificate of Authorization #00000155  
 Engineer of Record: David D. Skipper, P.E. #58972

|  |          |                      |
|--|----------|----------------------|
| STATE OF FLORIDA<br>DEPARTMENT OF TRANSPORTATION |          |                      |
| ROAD NO.   | COUNTY   | FINANCIAL PROJECT ID |
|  | ESCAMBIA | 430002-1-52-01       |

**CROSS SECTIONS**

|           |  |
|-----------|--|
| SHEET NO. |  |
|-----------|--|

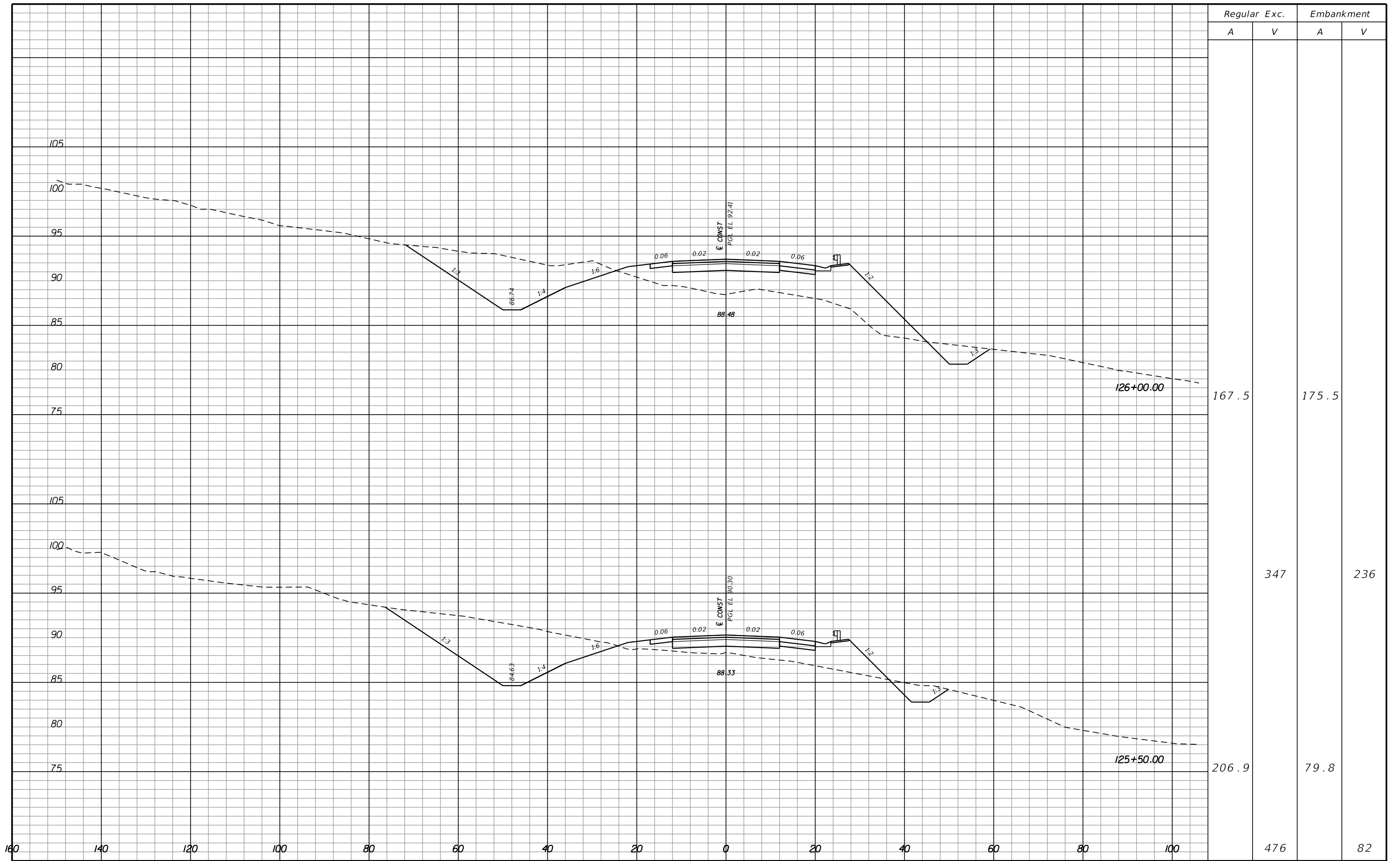

| REVISIONS |             |      |             |
|-----------|-------------|------|-------------|
| DATE      | DESCRIPTION | DATE | DESCRIPTION |
|           |             |      |             |
|           |             |      |             |

**Hatch Mott  
MacDonald**  
Post Office Box 2518 Pensacola, Florida 32513  
(850) 484-6011 - Certificate of Authorization #00000155  
Engineer of Record: David D. Skipper, P.E. #58972

| STATE OF FLORIDA<br>DEPARTMENT OF TRANSPORTATION |          |                      |
|--|----------|----------------------|
| ROAD NO.   | COUNTY   | FINANCIAL PROJECT ID |
|  | ESCAMBIA | 430002-1-52-01       |

|                         |              |
|-------------------------|--------------|
| <h2>CROSS SECTIONS</h2> | SHEET<br>NO. |
|-------------------------|--------------|

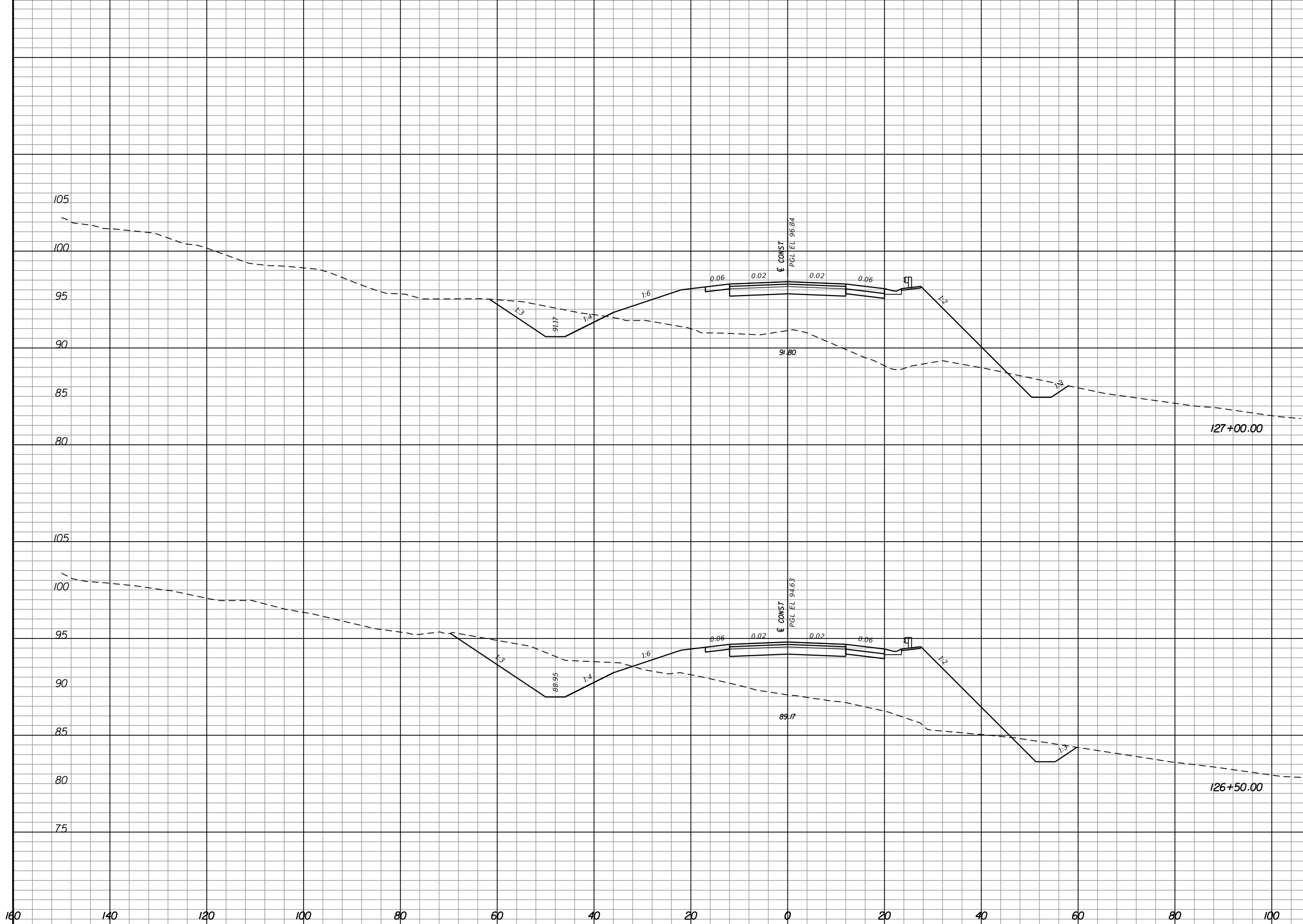

| Regular |     | Exc. |     | Embankment |     |
|---------|-----|------|-----|------------|-----|
| A       | V   | A    | V   | A          | V   |
| 57.2    |     |      |     | 350.5      |     |
| 110.2   |     |      | 155 | 310.7      | 612 |
|         | 257 |      |     |            | 450 |

| REVISIONS |             |      |             |
|-----------|-------------|------|-------------|
| DATE      | DESCRIPTION | DATE | DESCRIPTION |
|           |             |      |             |

**Hatch Mott MacDonald**  
 Post Office Box 2518 Pensacola, Florida 32513  
 (850) 484-6011 - Certificate of Authorization #00000155  
 Engineer of Record: David D. Skipper, P.E. #58972

|  |          |                      |
|--|----------|----------------------|
| STATE OF FLORIDA<br>DEPARTMENT OF TRANSPORTATION |          |                      |
| ROAD NO.   | COUNTY   | FINANCIAL PROJECT ID |
|  | ESCAMBIA | 430002-1-52-01       |

**CROSS SECTIONS**

SHEET NO.

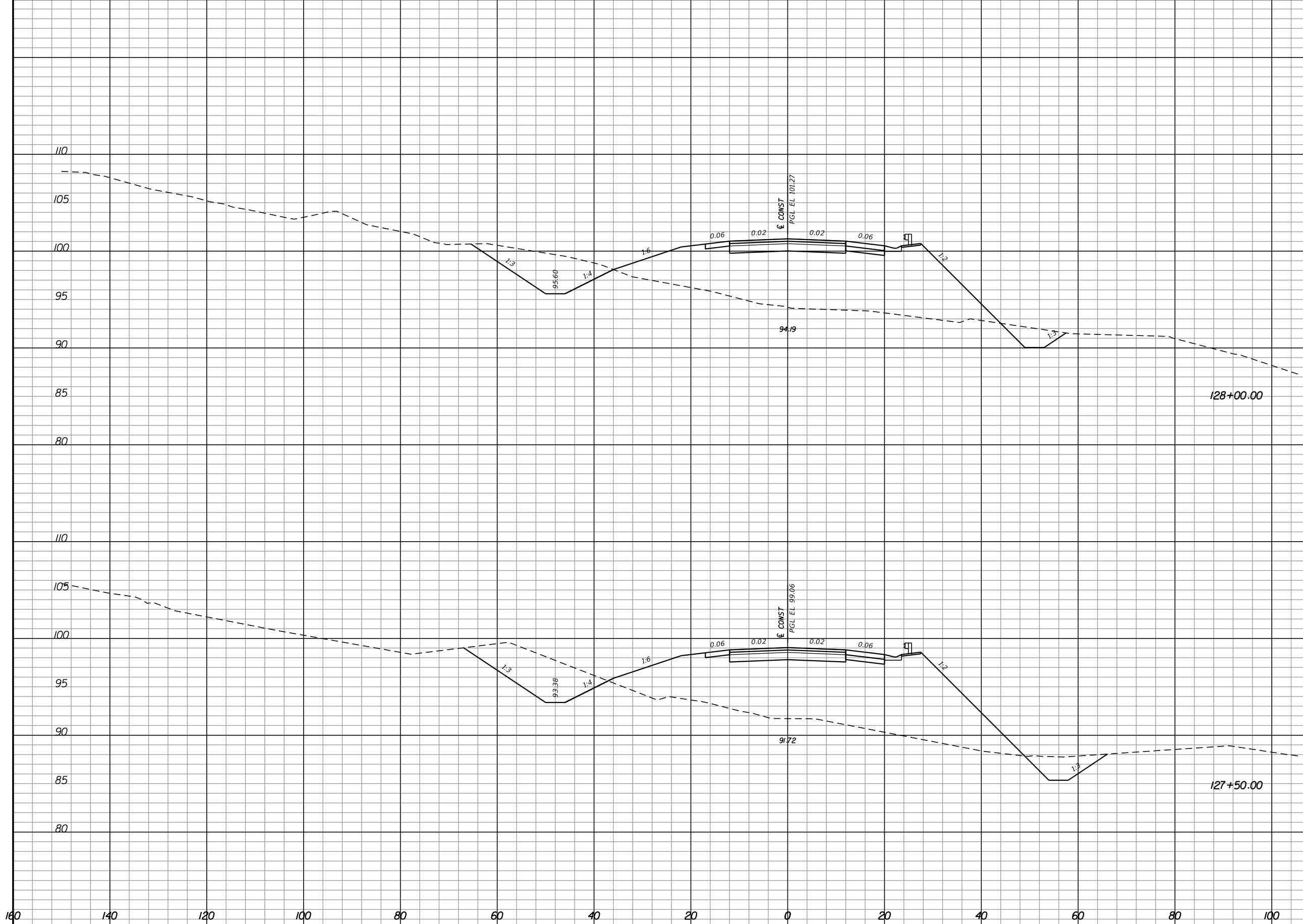

| Regular Exc. |     | Embankment |     |
|--------------|-----|------------|-----|
| A            | V   | A          | V   |
| 87.9         |     | 371.3      |     |
|              | 183 |            | 754 |
| 110.0        |     | 442.9      |     |
|              | 155 |            | 735 |

| REVISIONS |             |      |             |
|-----------|-------------|------|-------------|
| DATE      | DESCRIPTION | DATE | DESCRIPTION |
|           |             |      |             |

**Hatch Mott MacDonald**  
 Post Office Box 2518 Pensacola, Florida 32513  
 (850) 484-6011 - Certificate of Authorization #00000155  
 Engineer of Record: David D. Skipper, P.E. #58972

|  |          |                      |
|--|----------|----------------------|
| STATE OF FLORIDA<br>DEPARTMENT OF TRANSPORTATION |          |                      |
| ROAD NO.   | COUNTY   | FINANCIAL PROJECT ID |
|  | ESCAMBIA | 430002-1-52-01       |

**CROSS SECTIONS**

SHEET NO.

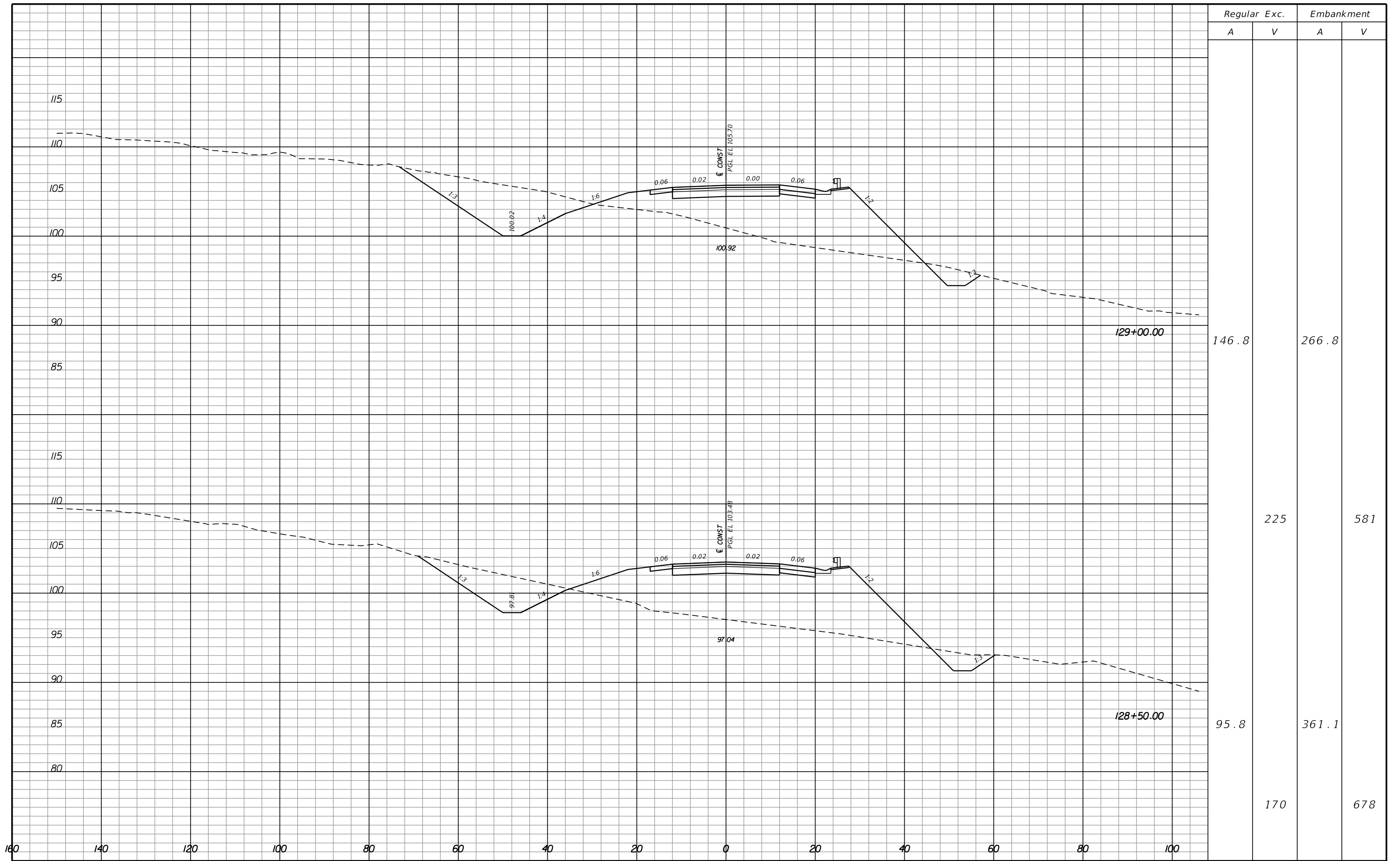

| REVISIONS |             |      |             |
|-----------|-------------|------|-------------|
| DATE      | DESCRIPTION | DATE | DESCRIPTION |
|           |             |      |             |

**Hatch Mott MacDonald**  
 Post Office Box 2518 Pensacola, Florida 32513  
 (850) 484-6011 - Certificate of Authorization #00000155  
 Engineer of Record: David D. Skipper, P.E. #58972

|  |          |                      |
|--|----------|----------------------|
| STATE OF FLORIDA<br>DEPARTMENT OF TRANSPORTATION |          |                      |
| ROAD NO.   | COUNTY   | FINANCIAL PROJECT ID |
|  | ESCAMBIA | 430002-1-52-01       |

**CROSS SECTIONS**

SHEET NO.

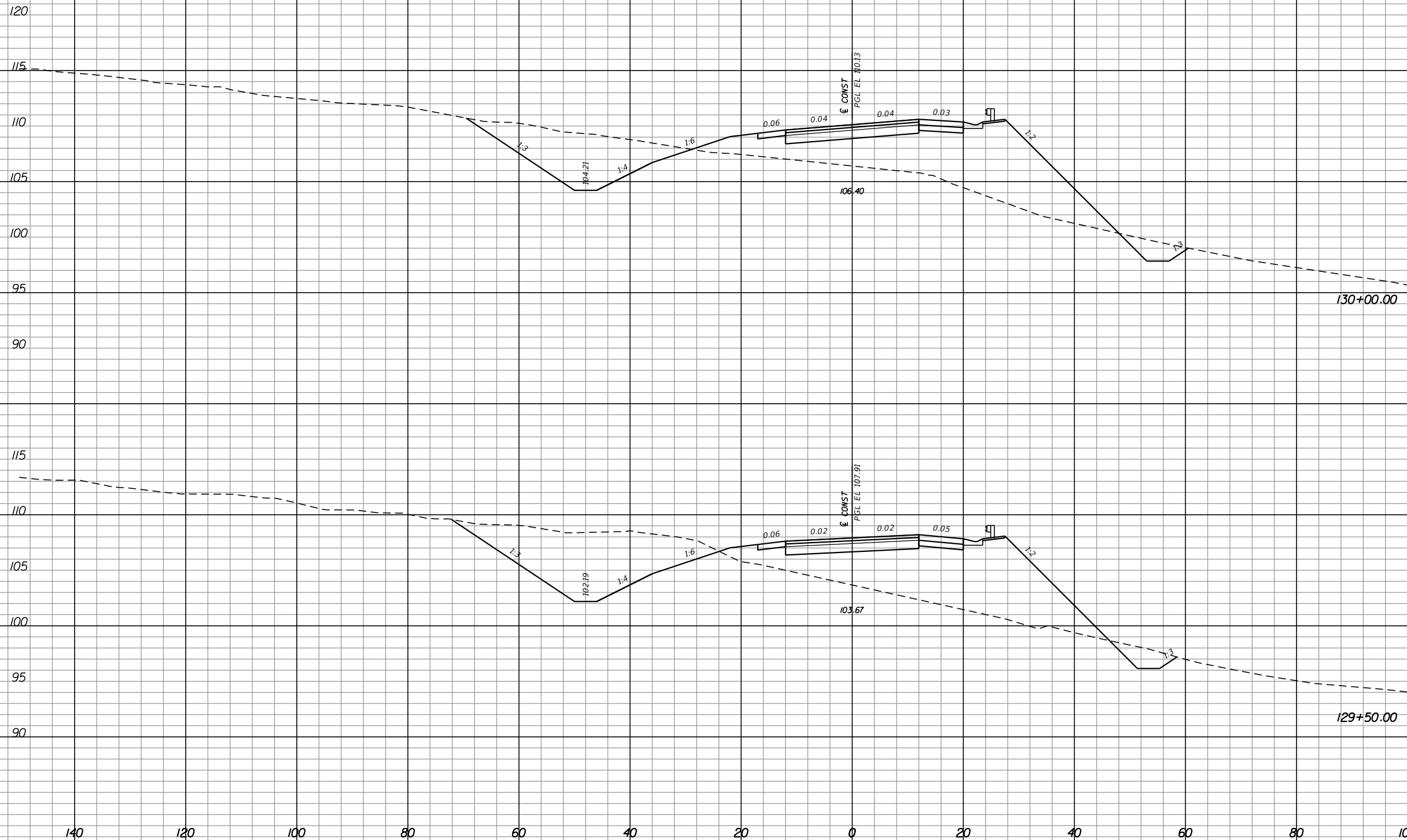

| Regular |   | Exc. |   | Embankment |     |
|---------|---|------|---|------------|-----|
| A       | V | A    | V | A          | V   |
| 126.2   |   |      |   | 245.0      |     |
|         |   | 285  |   |            | 456 |
| 182.1   |   |      |   | 247.9      |     |
|         |   | 305  |   |            | 477 |

| REVISIONS |             |      |             |
|-----------|-------------|------|-------------|
| DATE      | DESCRIPTION | DATE | DESCRIPTION |
|           |             |      |             |



**Hatch Mott MacDonald**  
Post Office Box 2518 Pensacola, Florida 32513  
 (850) 484-6011 - Certificate of Authorization #00000155  
 Engineer of Record: David D. Skipper, P.E. #58972

**STATE OF FLORIDA**  
**DEPARTMENT OF TRANSPORTATION**

|          |          |                      |
|----------|----------|----------------------|
| ROAD NO. | COUNTY   | FINANCIAL PROJECT ID |
|          | ESCAMBIA | 430002-1-52-01       |

**CROSS SECTIONS**

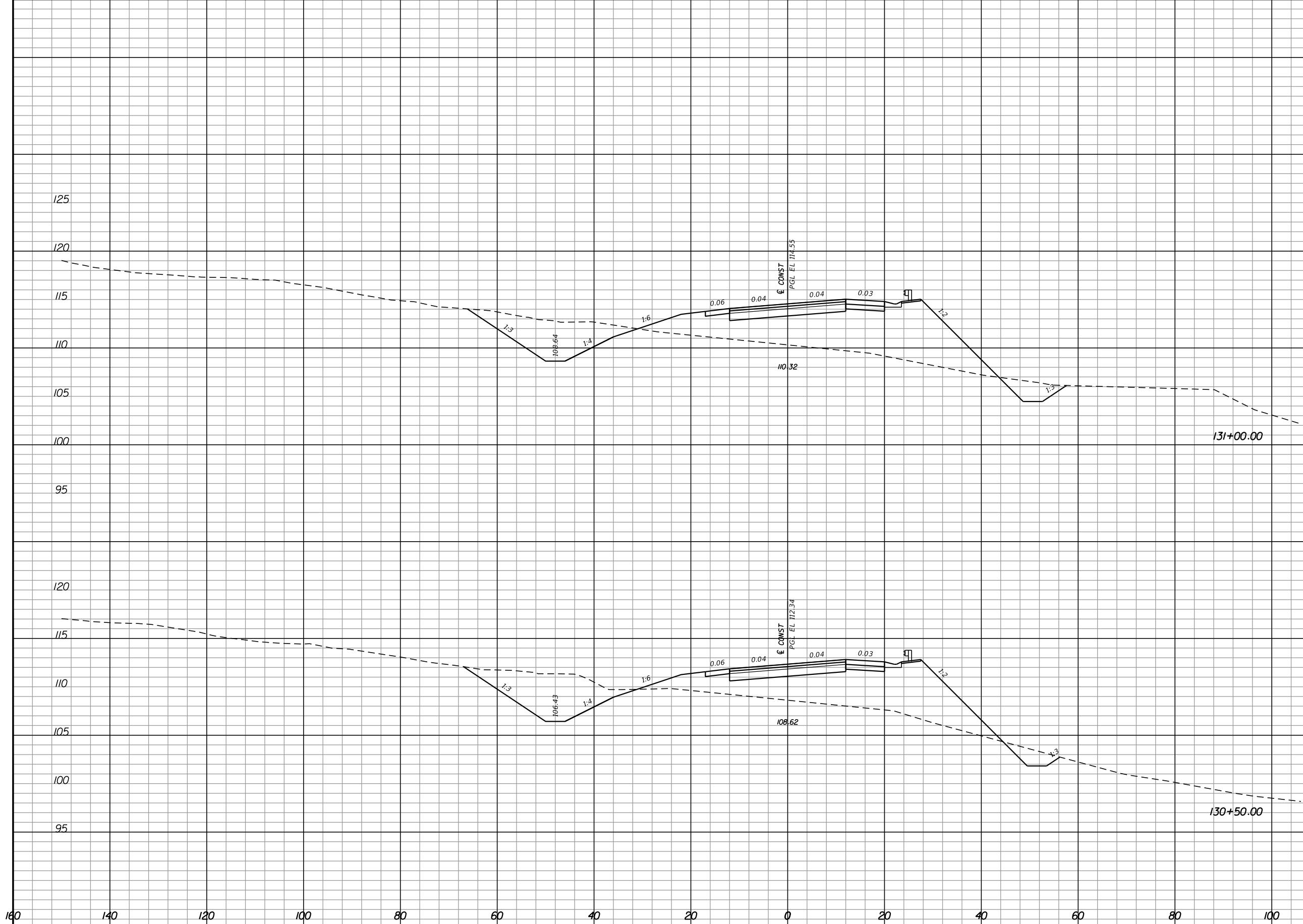
|           |
|-----------|
| SHEET NO. |
|-----------|



| Regular |   | Exc. |   | Embankment |     |
|---------|---|------|---|------------|-----|
| A       | V | A    | V | A          | V   |
| 100.0   |   |      |   | 236.9      |     |
|         |   | 190  |   |            | 410 |
| 105.1   |   |      |   | 206.0      |     |
|         |   | 214  |   |            | 418 |

| REVISIONS |             |      |             |
|-----------|-------------|------|-------------|
| DATE      | DESCRIPTION | DATE | DESCRIPTION |
|           |             |      |             |

**Hatch Mott MacDonald**  
 Post Office Box 2518 Pensacola, Florida 32513  
 (850) 484-6011 - Certificate of Authorization #00000155  
 Engineer of Record: David D. Skipper, P.E. #58972

|  |          |                      |
|--|----------|----------------------|
| STATE OF FLORIDA<br>DEPARTMENT OF TRANSPORTATION |          |                      |
| ROAD NO.   | COUNTY   | FINANCIAL PROJECT ID |
|  | ESCAMBIA | 430002-1-52-01       |

**CROSS SECTIONS**

SHEET NO.

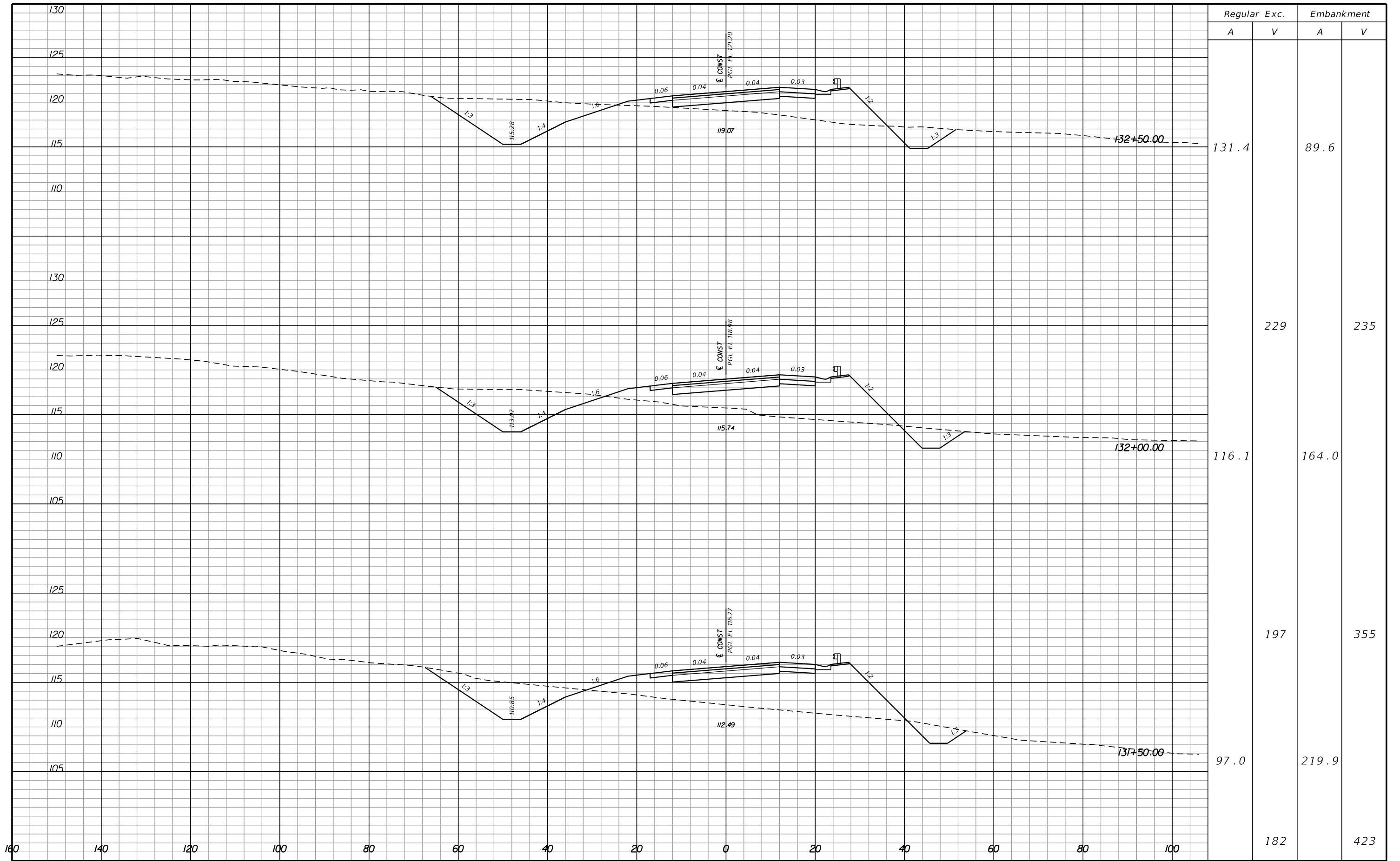

| Regular |     | Exc. |   | Embankment |     |
|---------|-----|------|---|------------|-----|
| A       | V   | A    | V | A          | V   |
| 131.4   |     |      |   | 89.6       |     |
|         | 229 |      |   |            | 235 |
| 116.1   |     |      |   | 164.0      |     |
|         | 197 |      |   |            | 355 |
| 97.0    |     |      |   | 219.9      |     |
|         | 182 |      |   |            | 423 |

| REVISIONS |             |      |             |
|-----------|-------------|------|-------------|
| DATE      | DESCRIPTION | DATE | DESCRIPTION |
|           |             |      |             |

**Hatch Mott MacDonald**  
 Post Office Box 2518 Pensacola, Florida 32513  
 (850) 484-6011 - Certificate of Authorization #00000155  
 Engineer of Record: David D. Skipper, P.E. #58972

|  |          |                      |
|--|----------|----------------------|
| STATE OF FLORIDA<br>DEPARTMENT OF TRANSPORTATION |          |                      |
| ROAD NO.   | COUNTY   | FINANCIAL PROJECT ID |
|  | ESCAMBIA | 430002-1-52-01       |

**CROSS SECTIONS**

SHEET NO.



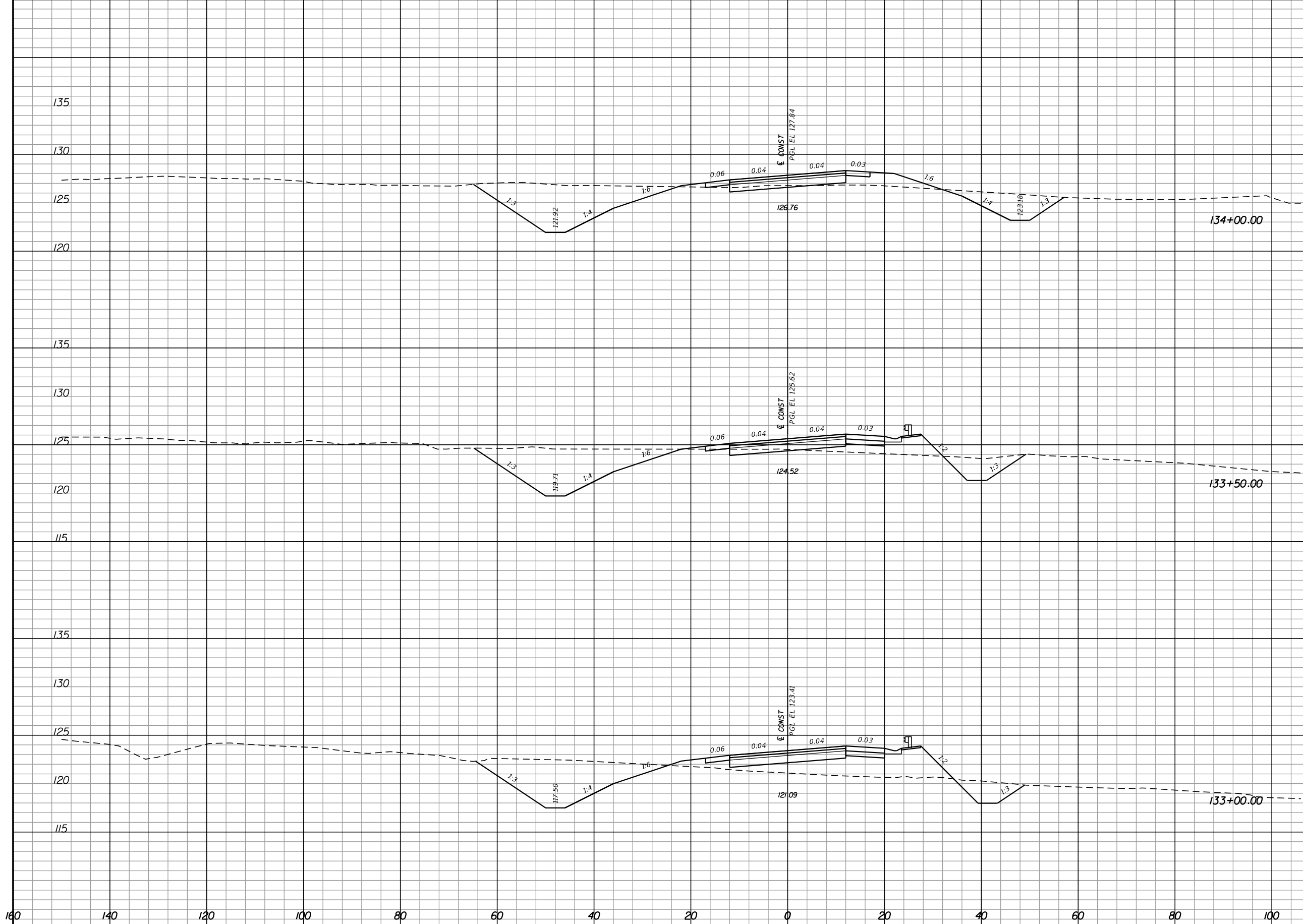

| Regular |     | Exc. |      | Embankment |     |
|---------|-----|------|------|------------|-----|
| A       | V   | A    | V    | A          | V   |
| 152.1   |     |      | 21.0 |            |     |
| 138.5   |     |      | 27.1 |            | 45  |
| 126.4   |     |      | 80.8 |            | 100 |
|         | 239 |      |      |            | 158 |

| REVISIONS |             |      |             |
|-----------|-------------|------|-------------|
| DATE      | DESCRIPTION | DATE | DESCRIPTION |
|           |             |      |             |

**Hatch Mott MacDonald**  
 Post Office Box 2518 Pensacola, Florida 32513  
 (850) 484-6011 - Certificate of Authorization #00000155  
 Engineer of Record: David D. Skipper, P.E. #58972

|  |          |                      |
|--|----------|----------------------|
| STATE OF FLORIDA<br>DEPARTMENT OF TRANSPORTATION |          |                      |
| ROAD NO.   | COUNTY   | FINANCIAL PROJECT ID |
|  | ESCAMBIA | 430002-1-52-01       |

**CROSS SECTIONS**

SHEET NO.

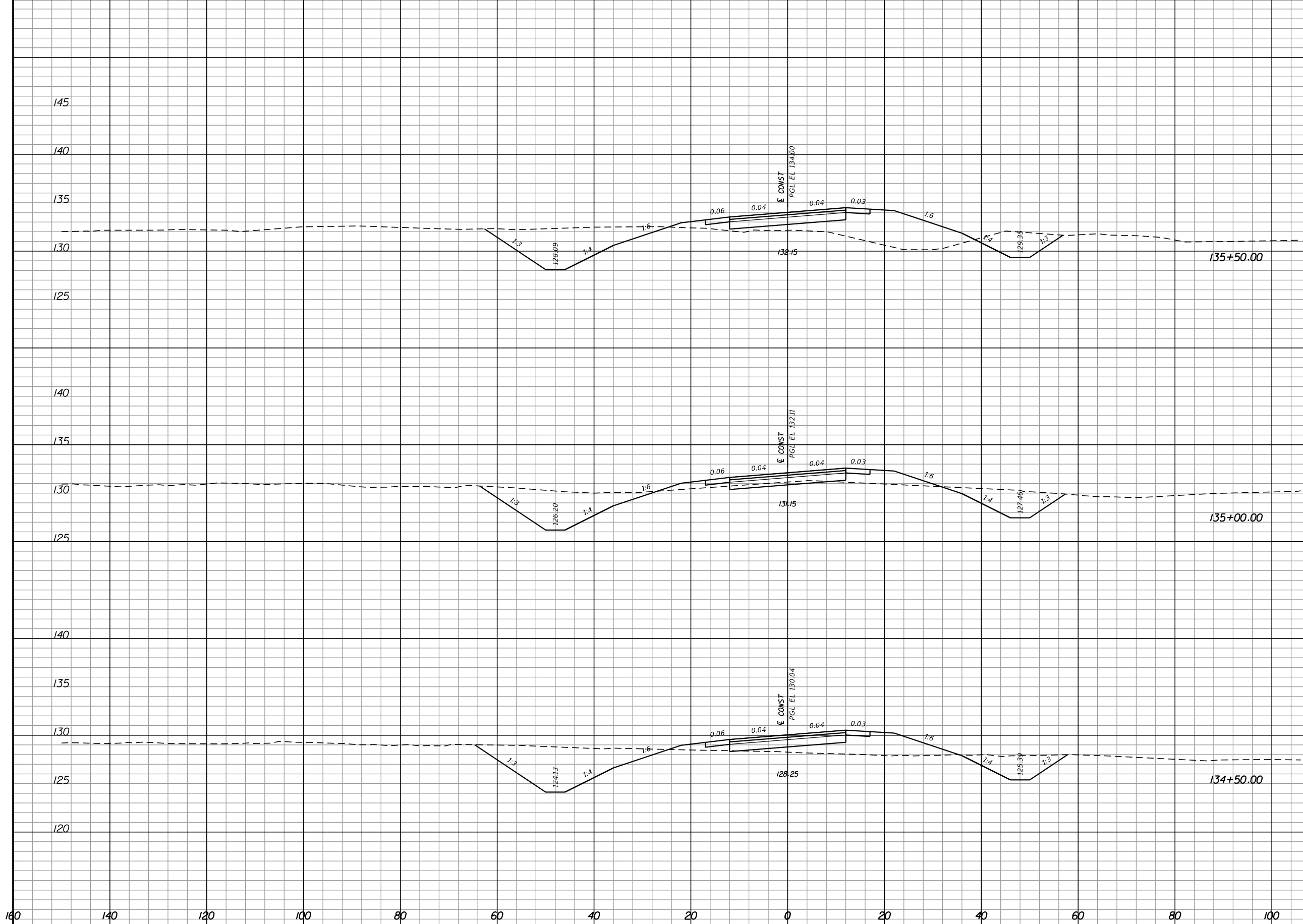

| Regular Exc. |     | Embankment |     |
|--------------|-----|------------|-----|
| A            | V   | A          | V   |
| 115.0        |     | 95.0       |     |
| 122.3        | 220 | 25.6       | 112 |
| 130.7        | 234 | 56.8       | 76  |
|              | 262 |            | 72  |

| REVISIONS |             |      |             |
|-----------|-------------|------|-------------|
| DATE      | DESCRIPTION | DATE | DESCRIPTION |
|           |             |      |             |

**Hatch Mott MacDonald**  
 Post Office Box 2518 Pensacola, Florida 32513  
 (850) 484-6011 - Certificate of Authorization #00000155  
 Engineer of Record: David D. Skipper, P.E. #58972

|  |          |                      |
|--|----------|----------------------|
| STATE OF FLORIDA<br>DEPARTMENT OF TRANSPORTATION |          |                      |
| ROAD NO.   | COUNTY   | FINANCIAL PROJECT ID |
|  | ESCAMBIA | 430002-1-52-01       |

**CROSS SECTIONS**

SHEET NO.

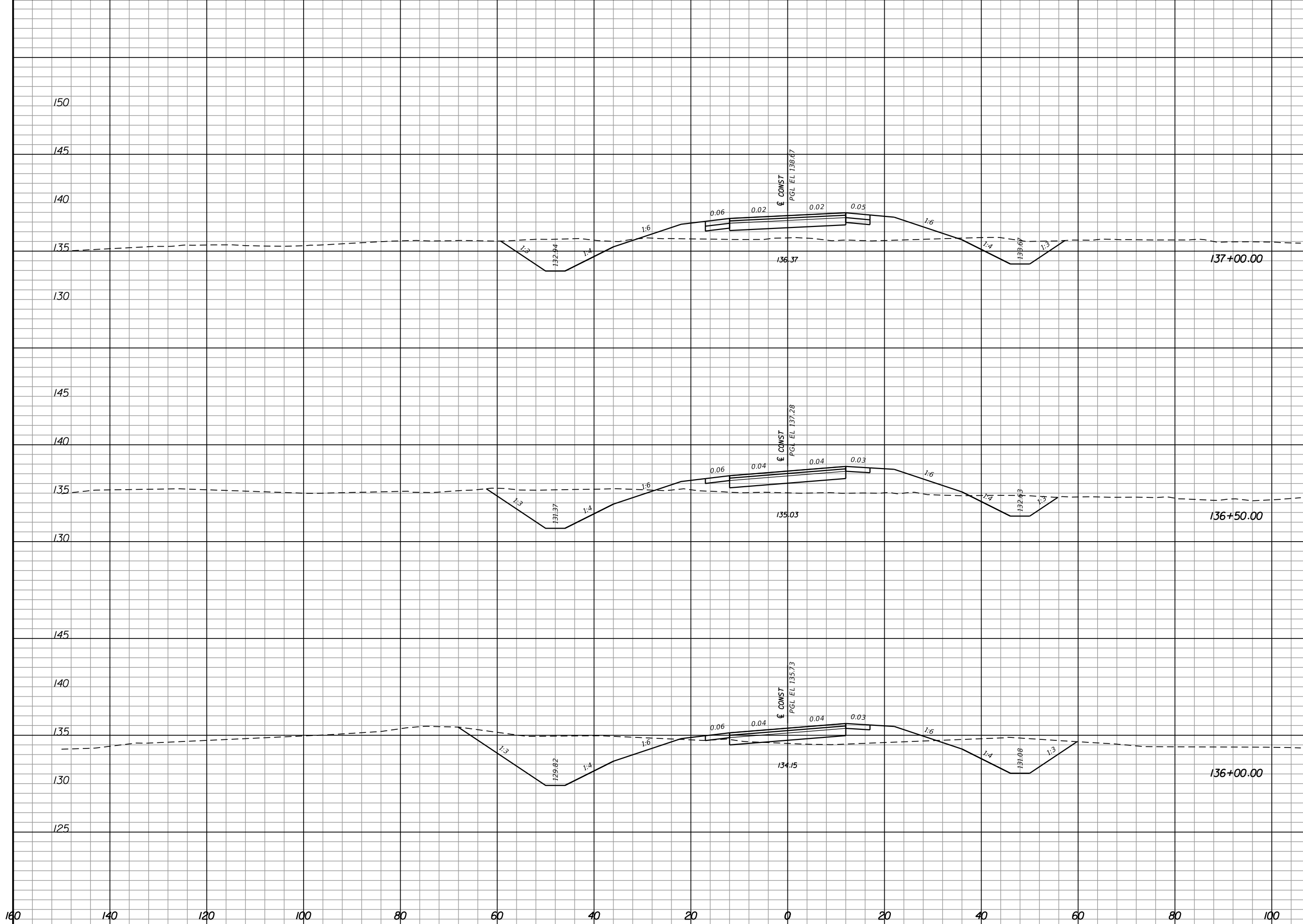

| Regular Exc. |     | Embankment |     |
|--------------|-----|------------|-----|
| A            | V   | A          | V   |
| 82.4         |     | 84.6       |     |
| 98.7         | 168 | 79.6       | 152 |
| 180.0        | 258 | 33.7       | 105 |
|              | 273 |            | 119 |

| REVISIONS |             |      |             |
|-----------|-------------|------|-------------|
| DATE      | DESCRIPTION | DATE | DESCRIPTION |
|           |             |      |             |

**Hatch Mott MacDonald**  
 Post Office Box 2518 Pensacola, Florida 32513  
 (850) 484-6011 - Certificate of Authorization #00000155  
 Engineer of Record: David D. Skipper, P.E. #58972

STATE OF FLORIDA  
 DEPARTMENT OF TRANSPORTATION

|          |          |                      |
|----------|----------|----------------------|
| ROAD NO. | COUNTY   | FINANCIAL PROJECT ID |
|          | ESCAMBIA | 430002-1-52-01       |

**CROSS SECTIONS**

SHEET NO.

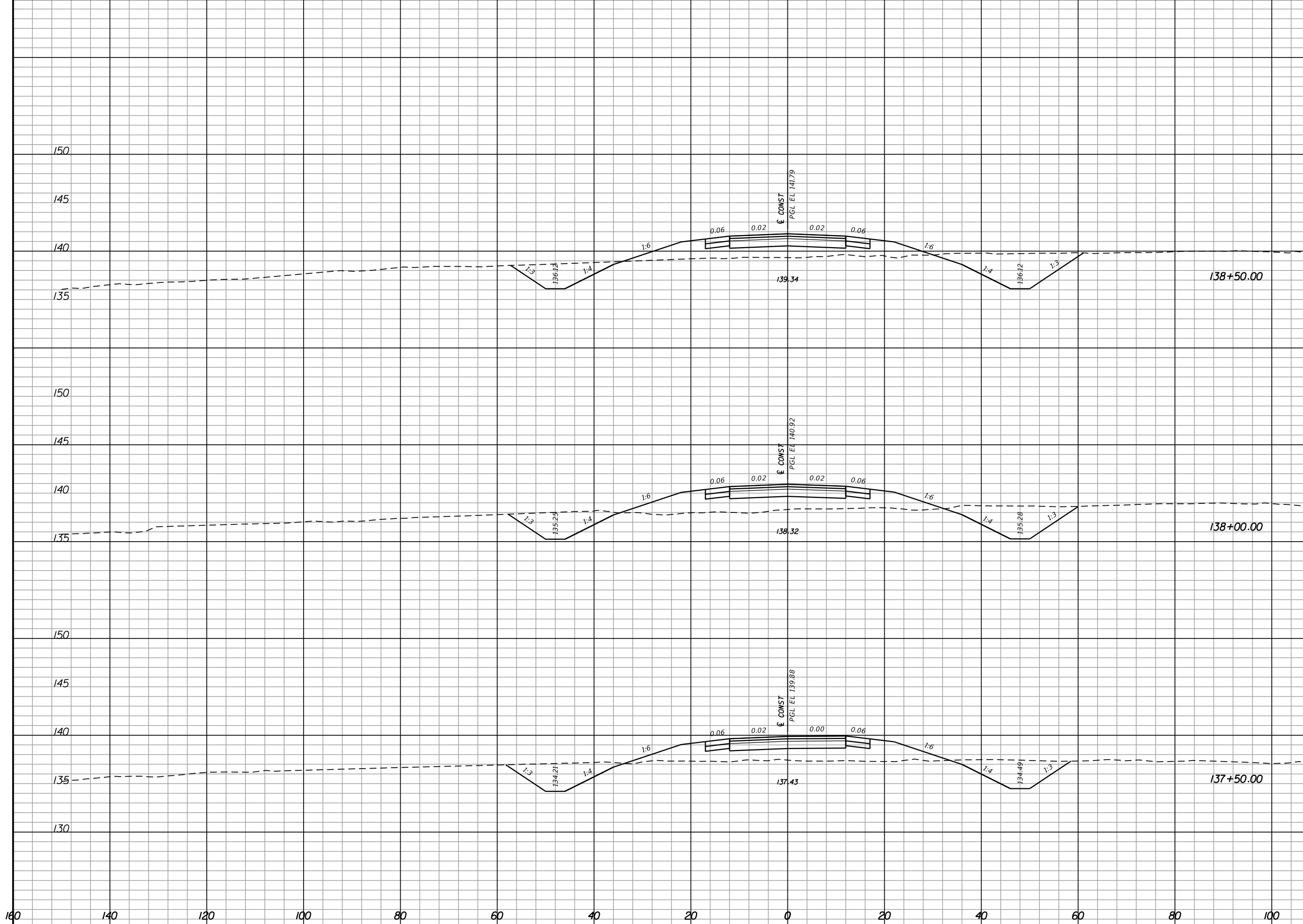

| Regular Exc. |     | Embankment |     |
|--------------|-----|------------|-----|
| A            | V   | A          | V   |
| 96.1         |     | 69.5       |     |
| 91.9         | 174 | 89.4       | 147 |
| 82.8         | 162 | 82.8       | 159 |
|              | 153 |            | 155 |

| REVISIONS |             |      |             |
|-----------|-------------|------|-------------|
| DATE      | DESCRIPTION | DATE | DESCRIPTION |
|           |             |      |             |

**Hatch Mott MacDonald**  
 Post Office Box 2518 Pensacola, Florida 32513  
 (850) 484-6011 - Certificate of Authorization #00000155  
 Engineer of Record: David D. Skipper, P.E. #58972

|  |          |                      |
|--|----------|----------------------|
| STATE OF FLORIDA<br>DEPARTMENT OF TRANSPORTATION |          |                      |
| ROAD NO.   | COUNTY   | FINANCIAL PROJECT ID |
|  | ESCAMBIA | 430002-1-52-01       |

**CROSS SECTIONS**

SHEET NO.

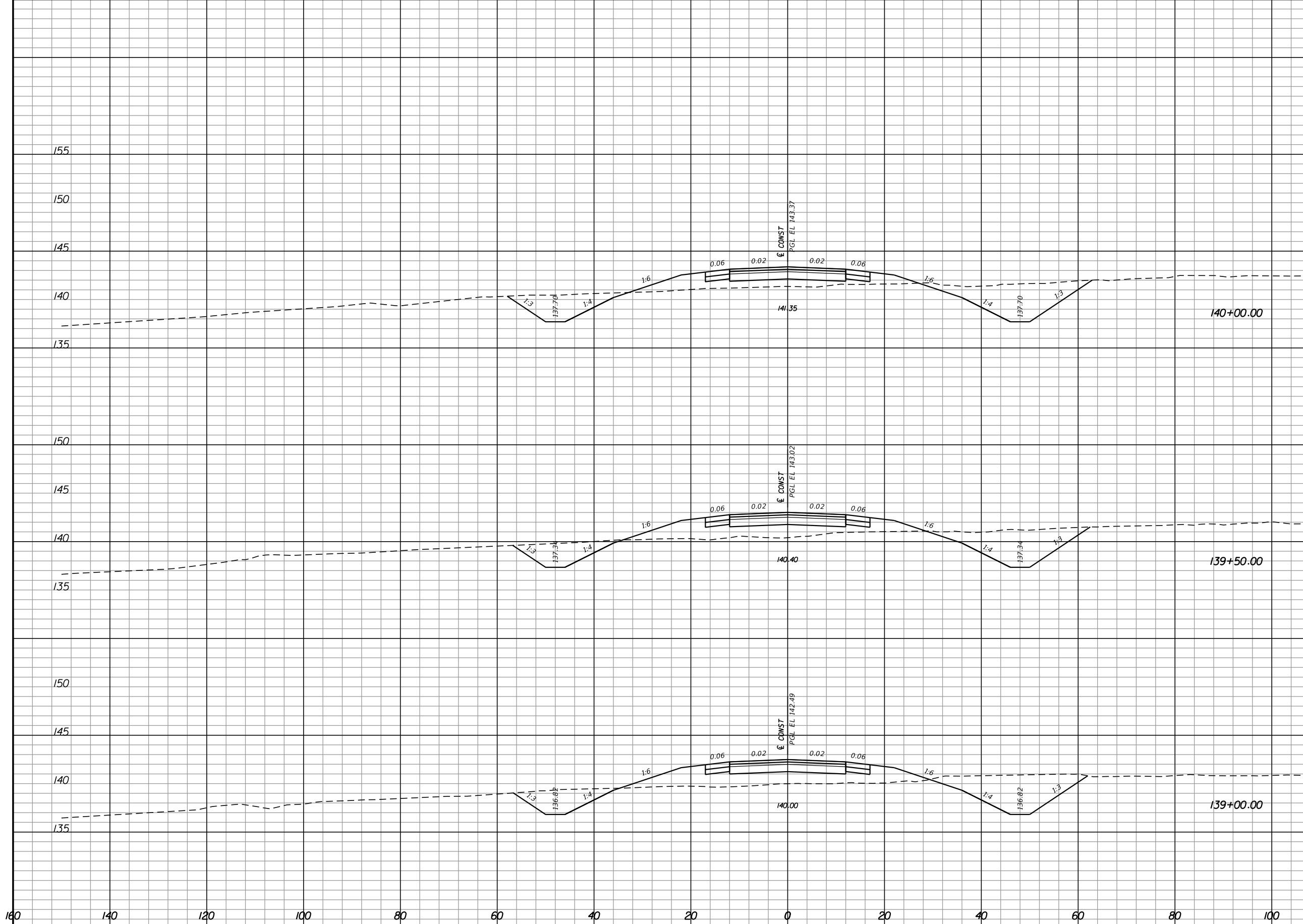

| Regular |     | Exc. |   | Embankment |     |
|---------|-----|------|---|------------|-----|
| A       | V   | A    | V | A          | V   |
| 110.5   |     |      |   | 47.1       |     |
| 100.7   | 196 |      |   | 67.7       | 106 |
| 107.5   | 193 |      |   | 77.9       | 135 |
|         | 189 |      |   |            | 136 |

| REVISIONS |             |      |             |
|-----------|-------------|------|-------------|
| DATE      | DESCRIPTION | DATE | DESCRIPTION |
|           |             |      |             |

**Hatch Mott MacDonald**  
 Post Office Box 2518 Pensacola, Florida 32513  
 (850) 484-6011 - Certificate of Authorization #00000155  
 Engineer of Record: David D. Skipper, P.E. #58972

|  |          |                      |
|--|----------|----------------------|
| STATE OF FLORIDA<br>DEPARTMENT OF TRANSPORTATION |          |                      |
| ROAD NO.   | COUNTY   | FINANCIAL PROJECT ID |
|  | ESCAMBIA | 430002-1-52-01       |

**CROSS SECTIONS**

SHEET NO.

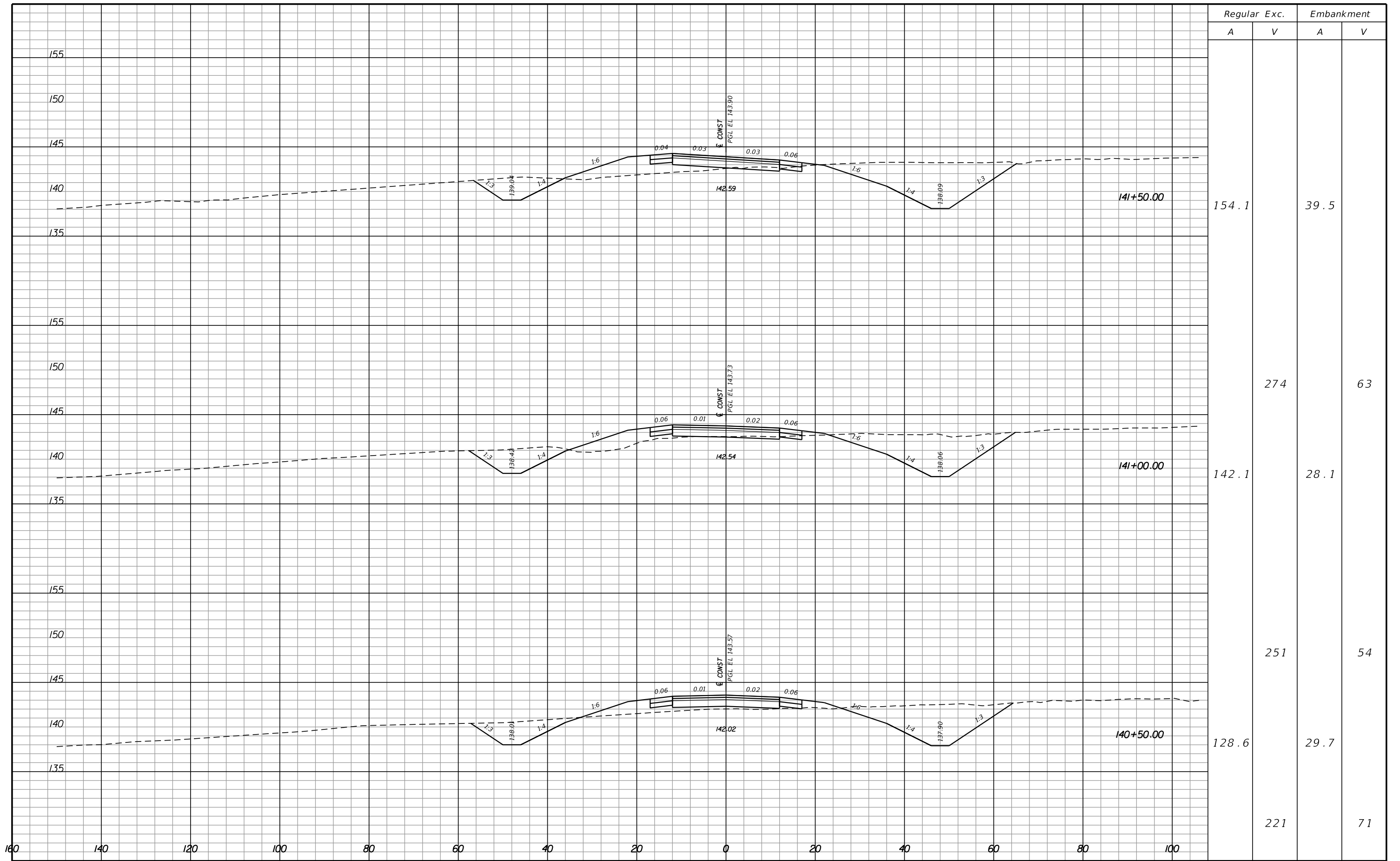

| REVISIONS |             |      |             |
|-----------|-------------|------|-------------|
| DATE      | DESCRIPTION | DATE | DESCRIPTION |
|           |             |      |             |



**Hatch Mott MacDonald**  
 Post Office Box 2518 Pensacola, Florida 32513  
 (850) 484-6011 - Certificate of Authorization #00000155  
 Engineer of Record: David D. Skipper, P.E. #58972

|  |          |                      |
|--|----------|----------------------|
| STATE OF FLORIDA<br>DEPARTMENT OF TRANSPORTATION |          |                      |
| ROAD NO.   | COUNTY   | FINANCIAL PROJECT ID |
|  | ESCAMBIA | 430002-1-52-01       |

CROSS SECTIONS

|           |  |
|-----------|--|
| SHEET NO. |  |
|-----------|--|

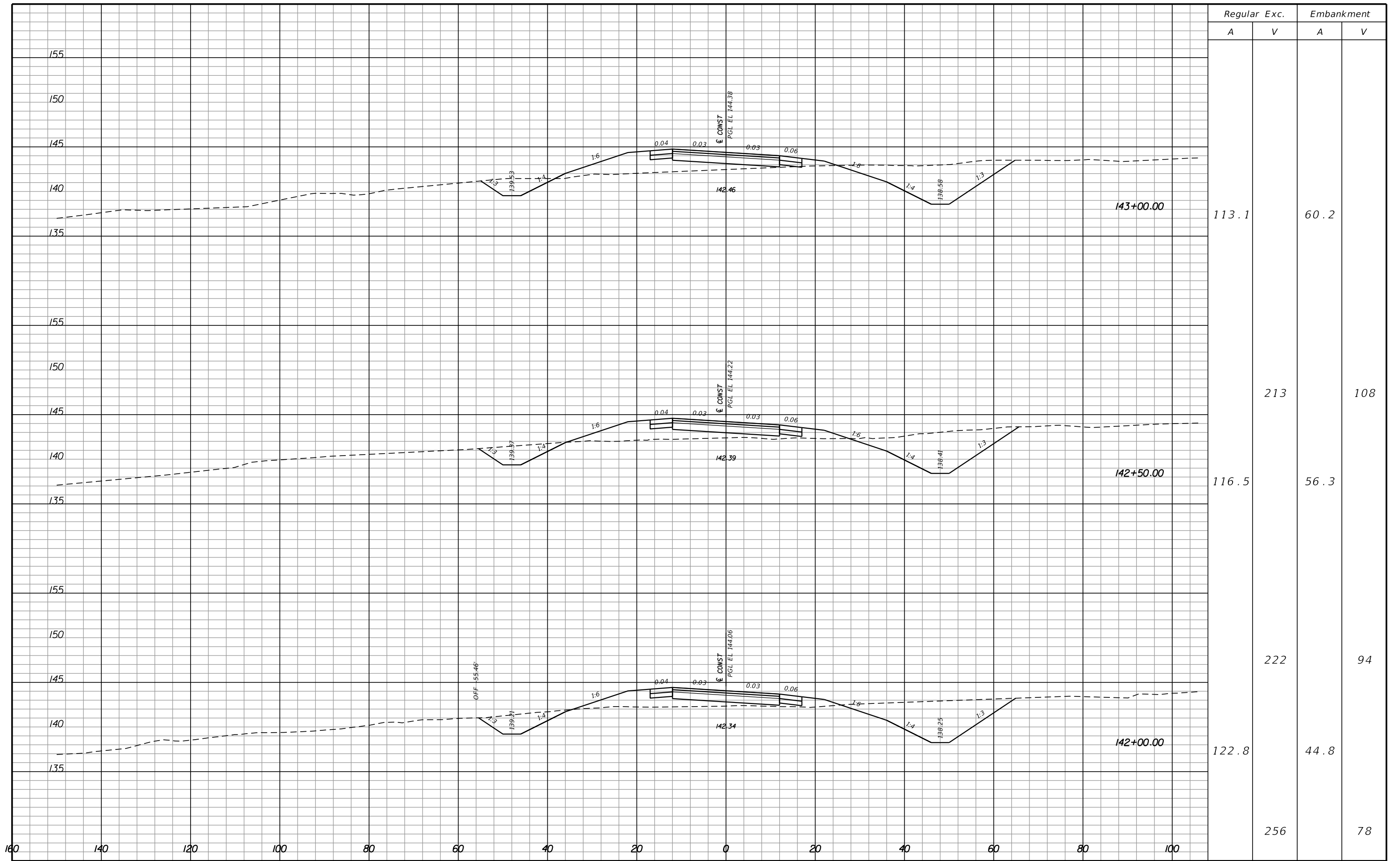

| Regular |     | Exc. |      | Embankment |     |
|---------|-----|------|------|------------|-----|
| A       | V   | A    | V    | A          | V   |
| 113.1   |     |      | 60.2 |            |     |
| 116.5   | 213 |      | 56.3 |            | 108 |
| 122.8   | 222 |      | 44.8 |            | 94  |
|         | 256 |      |      |            | 78  |

| REVISIONS |             |      |             |
|-----------|-------------|------|-------------|
| DATE      | DESCRIPTION | DATE | DESCRIPTION |
|           |             |      |             |

**Hatch Mott MacDonald**  
 Post Office Box 2518 Pensacola, Florida 32513  
 (850) 484-6011 - Certificate of Authorization #00000155  
 Engineer of Record: David D. Skipper, P.E. #58972

|  |          |                      |
|--|----------|----------------------|
| STATE OF FLORIDA<br>DEPARTMENT OF TRANSPORTATION |          |                      |
| ROAD NO.   | COUNTY   | FINANCIAL PROJECT ID |
|  | ESCAMBIA | 430002-1-52-01       |

**CROSS SECTIONS**

SHEET NO.

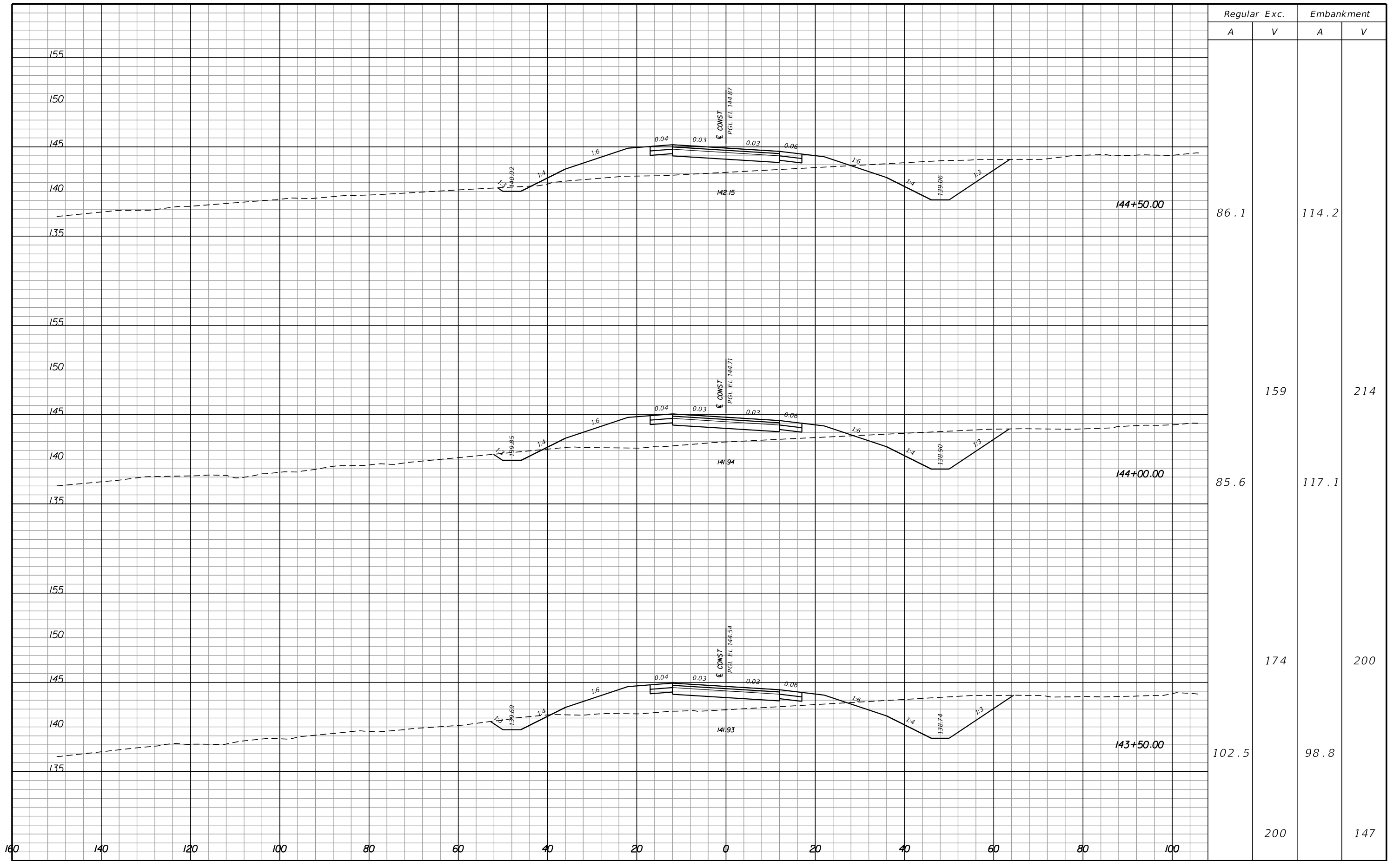

| REVISIONS |             |      |             |
|-----------|-------------|------|-------------|
| DATE      | DESCRIPTION | DATE | DESCRIPTION |
|           |             |      |             |



**Hatch Mott MacDonald**  
 Post Office Box 2518 Pensacola, Florida 32513  
 (850) 484-6011 - Certificate of Authorization #00000155  
 Engineer of Record: David D. Skipper, P.E. #58972

|  |          |                      |
|--|----------|----------------------|
| STATE OF FLORIDA<br>DEPARTMENT OF TRANSPORTATION |          |                      |
| ROAD NO.   | COUNTY   | FINANCIAL PROJECT ID |
|  | ESCAMBIA | 430002-1-52-01       |

**CROSS SECTIONS**

|           |
|-----------|
| SHEET NO. |
|           |



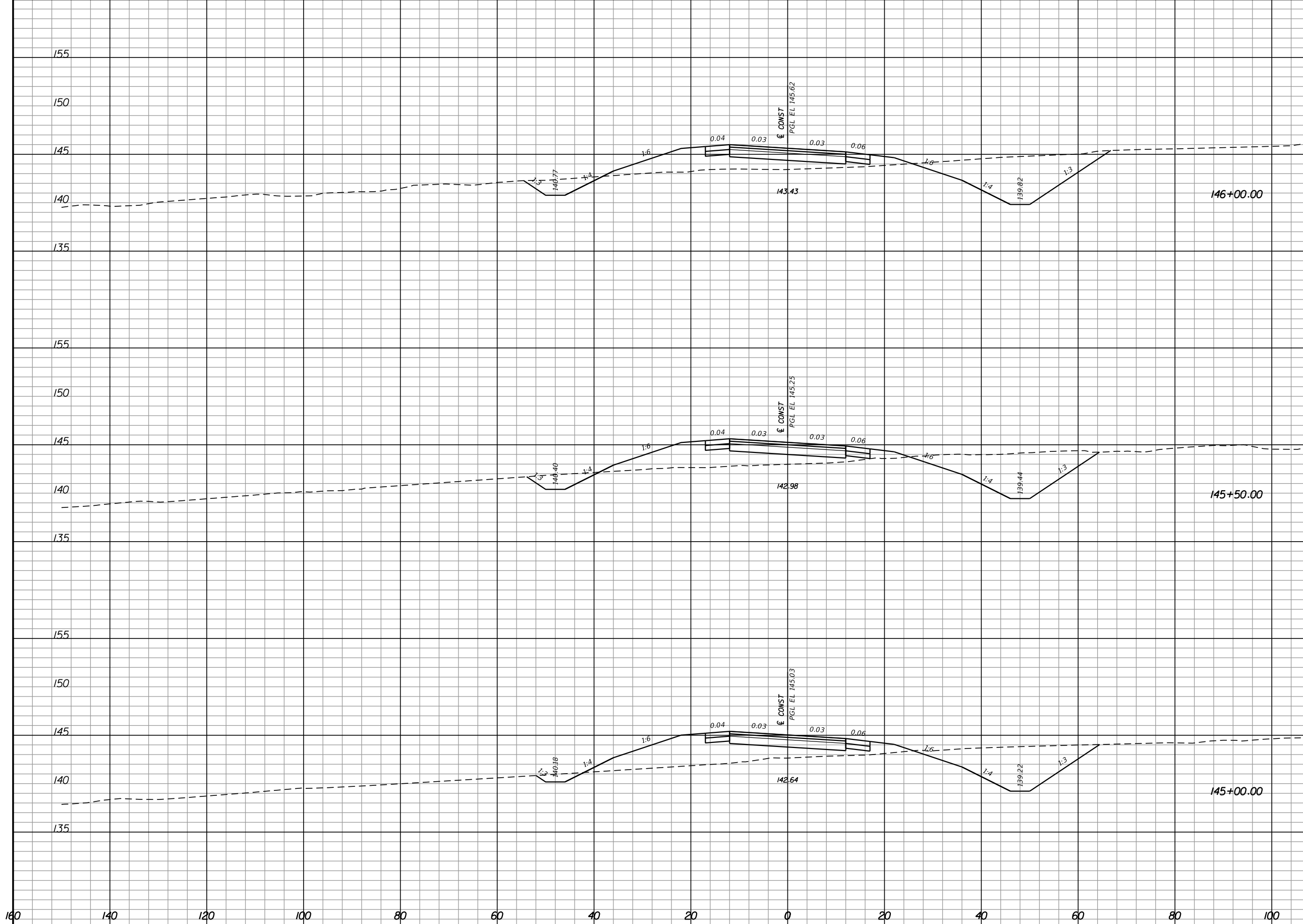

| Regular |     | Exc.  |      | Embankment |   |
|---------|-----|-------|------|------------|---|
| A       | V   | A     | V    | A          | V |
| 122.8   |     |       | 69.1 |            |   |
| 113.3   | 219 | 76.9  |      | 135        |   |
| 98.7    | 196 | 101.8 |      | 165        |   |
|         | 171 |       | 200  |            |   |

| REVISIONS |             |      |             |
|-----------|-------------|------|-------------|
| DATE      | DESCRIPTION | DATE | DESCRIPTION |
|           |             |      |             |

**Hatch Mott MacDonald**  
 Post Office Box 2518 Pensacola, Florida 32513  
 (850) 484-6011 - Certificate of Authorization #00000155  
 Engineer of Record: David D. Skipper, P.E. #58972

|  |          |                      |
|--|----------|----------------------|
| STATE OF FLORIDA<br>DEPARTMENT OF TRANSPORTATION |          |                      |
| ROAD NO.   | COUNTY   | FINANCIAL PROJECT ID |
|  | ESCAMBIA | 430002-1-52-01       |

**CROSS SECTIONS**

SHEET NO.

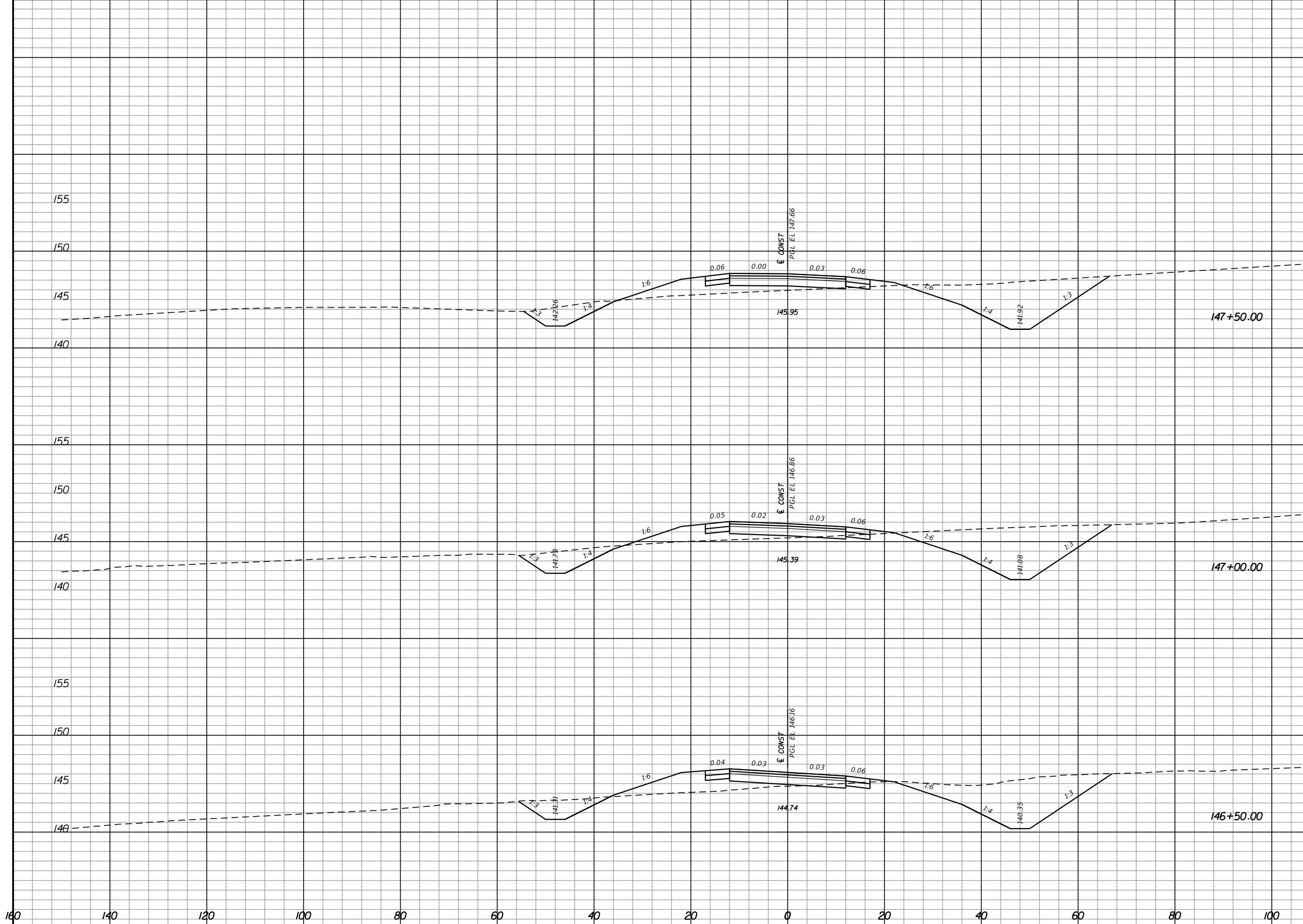

| Regular |     | Exc. |      | Embankment |     |
|---------|-----|------|------|------------|-----|
| A       | V   | A    | V    | A          | V   |
| 131.4   |     |      | 37.0 |            |     |
| 157.4   |     | 267  | 28.5 | 61         |     |
| 140.3   |     | 276  | 39.7 | 63         |     |
|         | 244 |      |      |            | 101 |

| REVISIONS |             |      |             |
|-----------|-------------|------|-------------|
| DATE      | DESCRIPTION | DATE | DESCRIPTION |
|           |             |      |             |

**Hatch Mott MacDonald**  
 Post Office Box 2518 Pensacola, Florida 32513  
 (850) 484-6011 - Certificate of Authorization #00000155  
 Engineer of Record: David D. Skipper, P.E. #58972

STATE OF FLORIDA  
 DEPARTMENT OF TRANSPORTATION

| ROAD NO. | COUNTY   | FINANCIAL PROJECT ID |
|----------|----------|----------------------|
|          | ESCAMBIA | 430002-1-52-01       |

**CROSS SECTIONS**

SHEET NO.

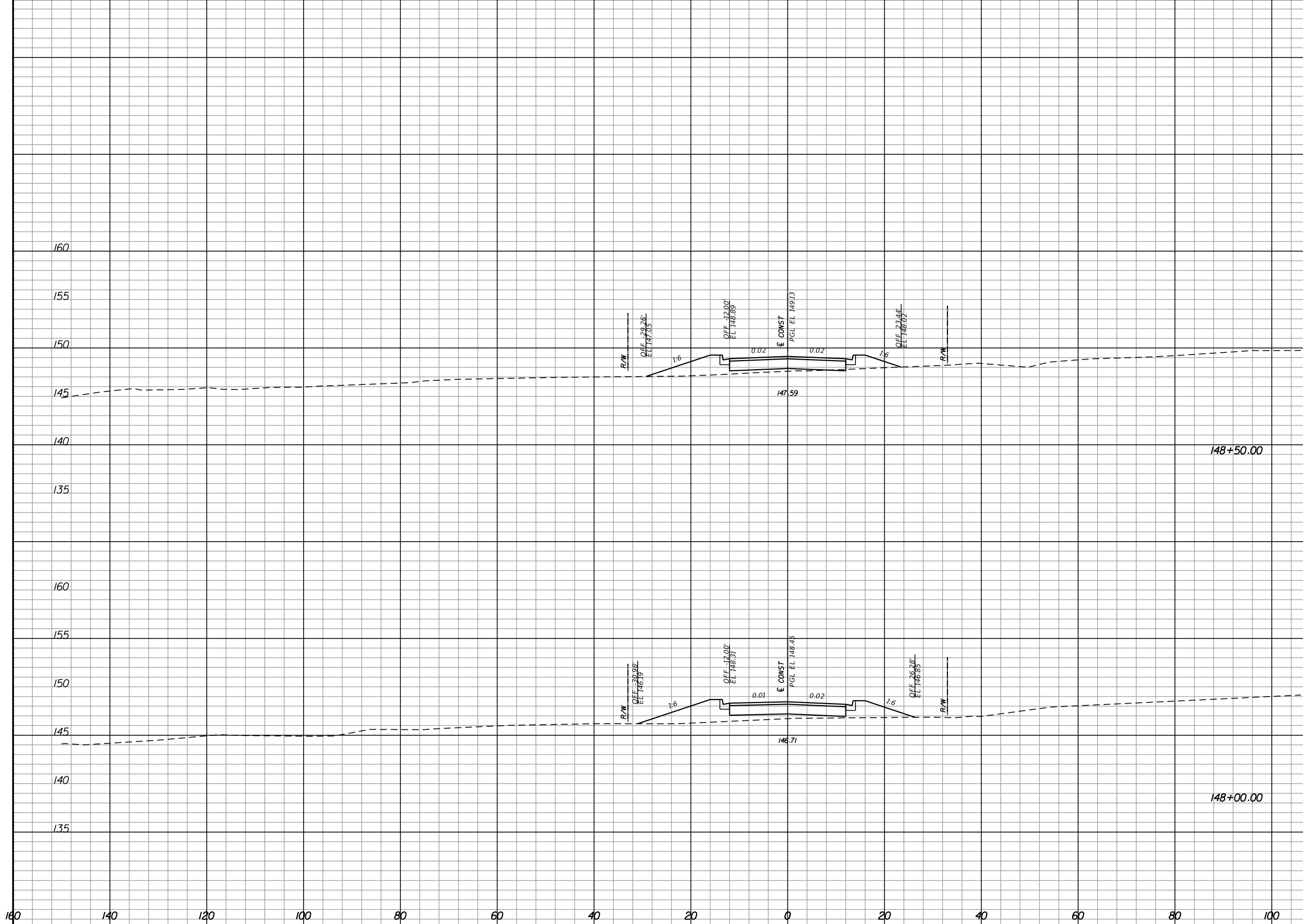

| Regular |     | Exc. |   | Embankment |    |
|---------|-----|------|---|------------|----|
| A       | V   | A    | V | A          | V  |
| 0.3     |     |      |   | 33.9       |    |
| 0.0     | 0   |      |   | 49.9       | 78 |
|         | 122 |      |   |            | 80 |

| REVISIONS |             |      |             |
|-----------|-------------|------|-------------|
| DATE      | DESCRIPTION | DATE | DESCRIPTION |
|           |             |      |             |

**Hatch Mott MacDonald**  
 Post Office Box 2518 Pensacola, Florida 32513  
 (850) 484-6011 - Certificate of Authorization #00000155  
 Engineer of Record: David D. Skipper, P.E. #58972

|  |          |                      |
|--|----------|----------------------|
| STATE OF FLORIDA<br>DEPARTMENT OF TRANSPORTATION |          |                      |
| ROAD NO.   | COUNTY   | FINANCIAL PROJECT ID |
|  | ESCAMBIA | 430002-1-52-01       |

**CROSS SECTIONS**

SHEET NO.

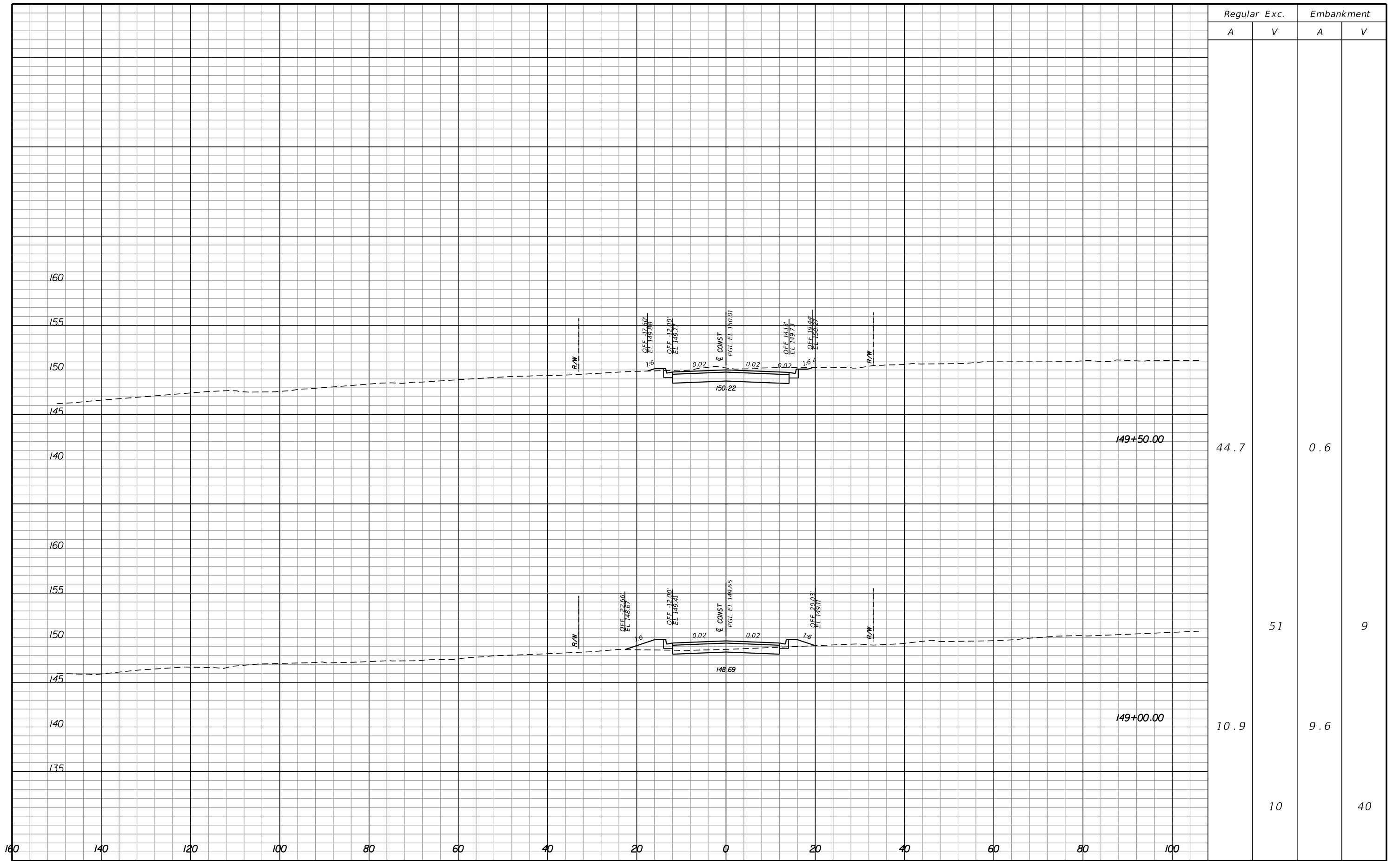

| Regular |    | Exc. |   | Embankment |    |
|---------|----|------|---|------------|----|
| A       | V  | A    | V | A          | V  |
| 44.7    |    | 0.6  |   |            |    |
| 10.9    | 51 | 9.6  |   |            | 9  |
|         | 10 |      |   |            | 40 |

| REVISIONS |             |      |             |
|-----------|-------------|------|-------------|
| DATE      | DESCRIPTION | DATE | DESCRIPTION |
|           |             |      |             |

**Hatch Mott MacDonald**  
 Post Office Box 2518 Pensacola, Florida 32513  
 (850) 484-6011 - Certificate of Authorization #00000155  
 Engineer of Record: David D. Skipper, P.E. #58972

|  |          |                      |
|--|----------|----------------------|
| STATE OF FLORIDA<br>DEPARTMENT OF TRANSPORTATION |          |                      |
| ROAD NO.   | COUNTY   | FINANCIAL PROJECT ID |
|  | ESCAMBIA | 430002-1-52-01       |

**CROSS SECTIONS**

|           |
|-----------|
| SHEET NO. |
|           |

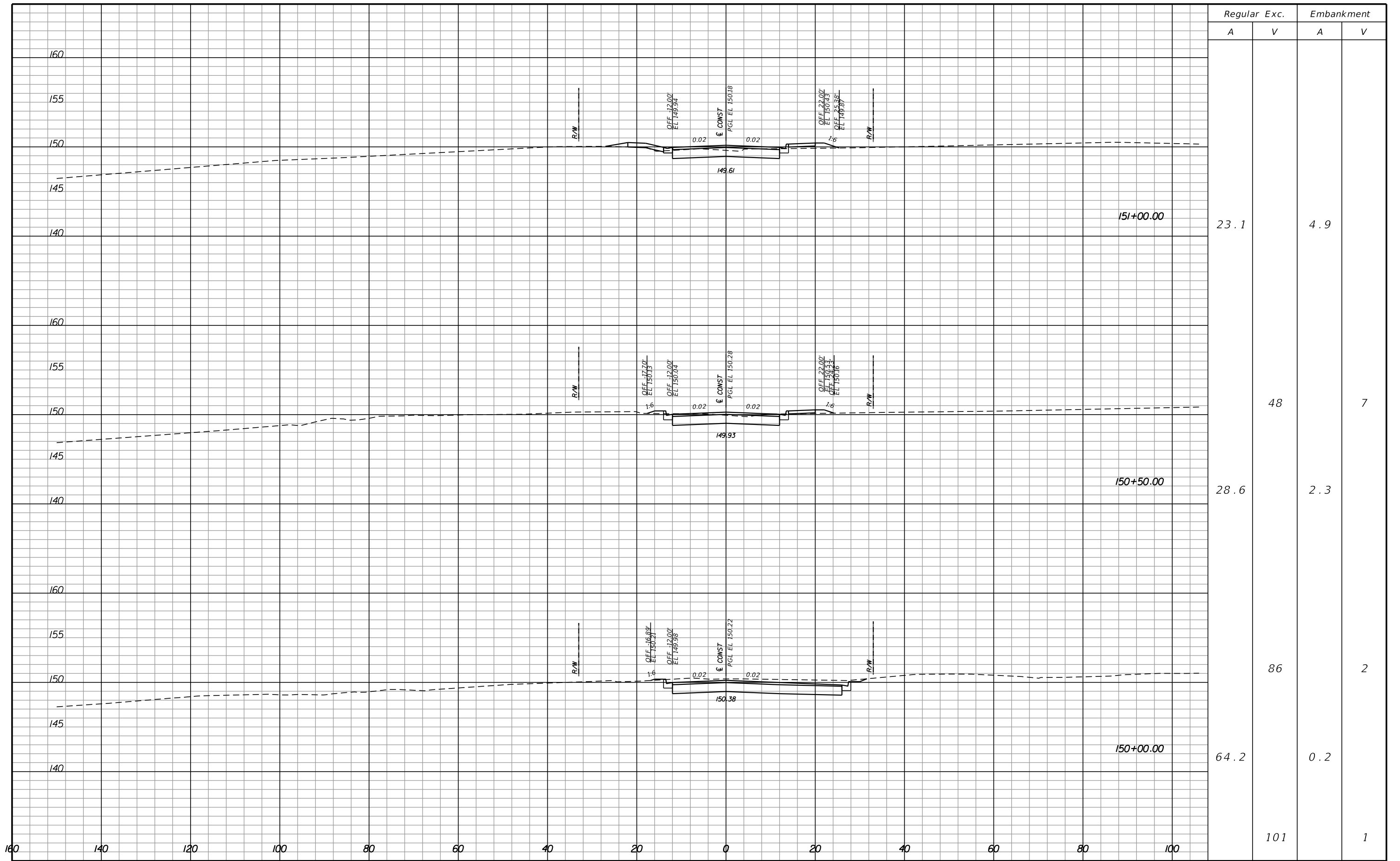

| Regular Exc. |     | Embankment |   |
|--------------|-----|------------|---|
| A            | V   | A          | V |
| 23.1         |     | 4.9        |   |
| 28.6         | 48  | 2.3        | 7 |
| 64.2         | 86  | 0.2        | 2 |
|              | 101 |            | 1 |

| REVISIONS |             |      |             |
|-----------|-------------|------|-------------|
| DATE      | DESCRIPTION | DATE | DESCRIPTION |
|           |             |      |             |

**Hatch Mott MacDonald**  
 Post Office Box 2518 Pensacola, Florida 32513  
 (850) 484-6011 - Certificate of Authorization #00000155  
 Engineer of Record: David D. Skipper, P.E. #58972

|  |          |                      |
|--|----------|----------------------|
| STATE OF FLORIDA<br>DEPARTMENT OF TRANSPORTATION |          |                      |
| ROAD NO.   | COUNTY   | FINANCIAL PROJECT ID |
|  | ESCAMBIA | 430002-1-52-01       |

**CROSS SECTIONS**

SHEET NO.

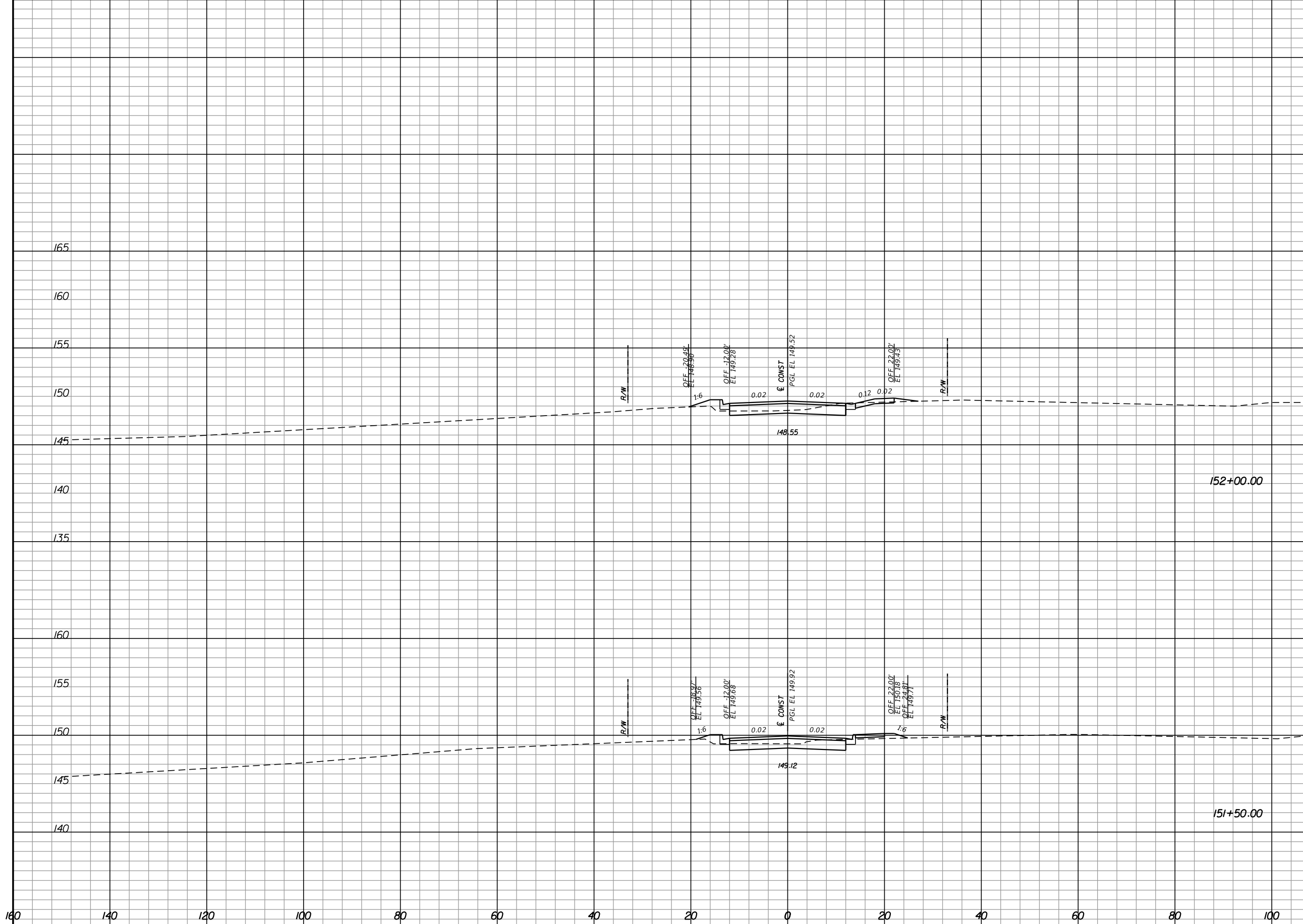

| Regular |    | Exc. |   | Embankment |   |
|---------|----|------|---|------------|---|
| A       | V  | A    | V | A          | V |
| 16.2    |    | 4.8  |   |            |   |
|         | 32 |      |   |            | 9 |
| 18.0    |    | 5.3  |   |            |   |
|         |    |      |   |            | 9 |
| 38      |    |      |   |            |   |

| REVISIONS |             |      |             |
|-----------|-------------|------|-------------|
| DATE      | DESCRIPTION | DATE | DESCRIPTION |
|           |             |      |             |

**Hatch Mott MacDonald**  
 Post Office Box 2518 Pensacola, Florida 32513  
 (850) 484-6011 - Certificate of Authorization #00000155  
 Engineer of Record: David D. Skipper, P.E. #58972

|  |          |                      |
|--|----------|----------------------|
| STATE OF FLORIDA<br>DEPARTMENT OF TRANSPORTATION |          |                      |
| ROAD NO.   | COUNTY   | FINANCIAL PROJECT ID |
|  | ESCAMBIA | 430002-1-52-01       |

**CROSS SECTIONS**

SHEET NO.

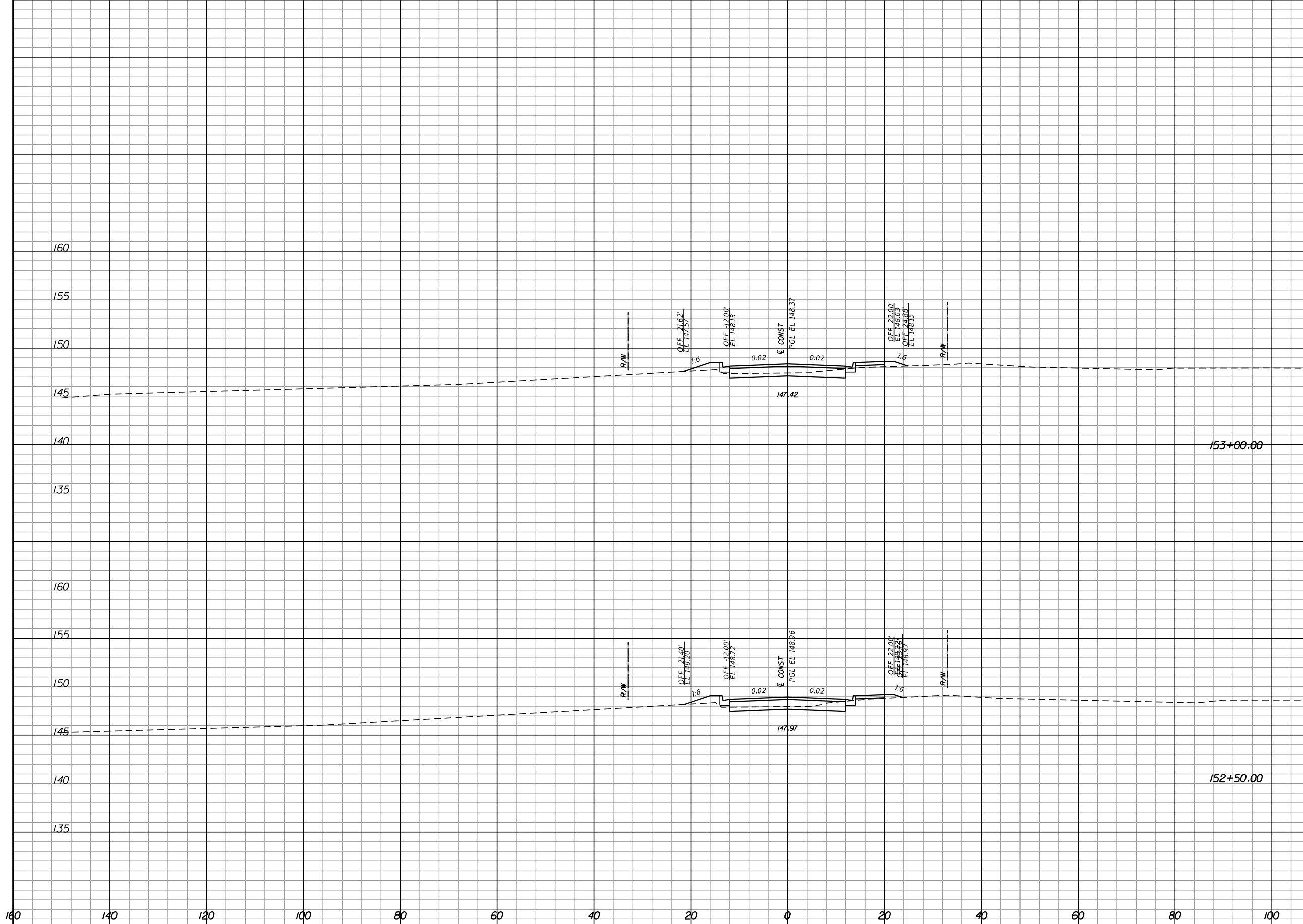

| Regular |    | Exc. |   | Embankment |    |
|---------|----|------|---|------------|----|
| A       | V  | A    | V | A          | V  |
| 12.2    |    |      |   | 7.1        |    |
|         | 22 |      |   |            | 12 |
| 12.1    |    |      |   | 5.5        |    |
|         | 26 |      |   |            | 10 |

| REVISIONS |             |      |             |
|-----------|-------------|------|-------------|
| DATE      | DESCRIPTION | DATE | DESCRIPTION |
|           |             |      |             |

**Hatch Mott MacDonald**  
 Post Office Box 2518 Pensacola, Florida 32513  
 (850) 484-6011 - Certificate of Authorization #00000155  
 Engineer of Record: David D. Skipper, P.E. #58972

|  |          |                      |
|--|----------|----------------------|
| STATE OF FLORIDA<br>DEPARTMENT OF TRANSPORTATION |          |                      |
| ROAD NO.   | COUNTY   | FINANCIAL PROJECT ID |
|  | ESCAMBIA | 430002-1-52-01       |

**CROSS SECTIONS**

SHEET NO.

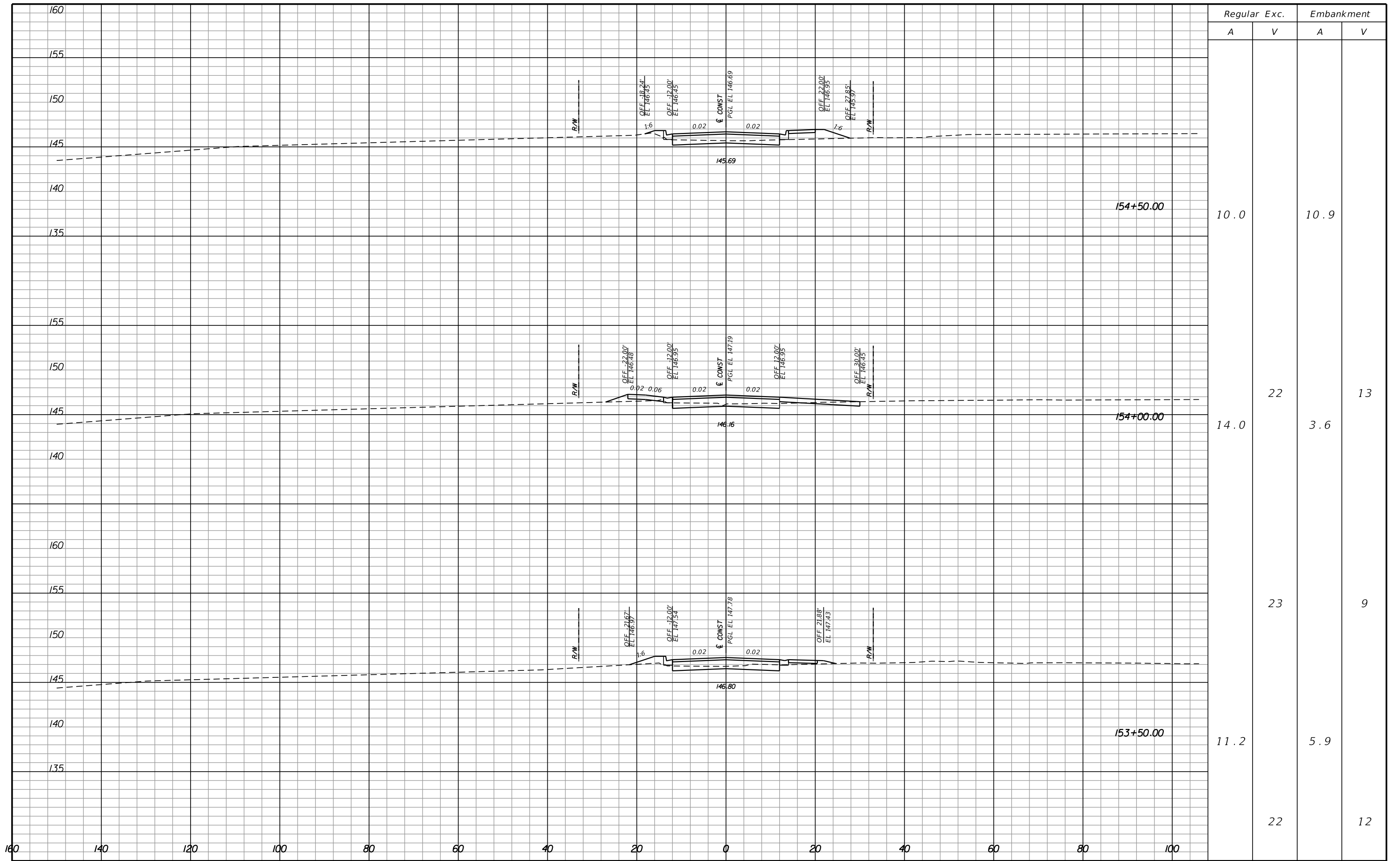

| Regular |    | Exc. |   | Embankment |    |
|---------|----|------|---|------------|----|
| A       | V  | A    | V | A          | V  |
| 10.0    |    |      |   | 10.9       |    |
| 14.0    | 22 | 3.6  |   |            | 13 |
| 11.2    | 23 | 5.9  |   |            | 9  |
|         | 22 |      |   |            | 12 |

| REVISIONS |             |      |             |
|-----------|-------------|------|-------------|
| DATE      | DESCRIPTION | DATE | DESCRIPTION |
|           |             |      |             |

**Hatch Mott MacDonald**  
 Post Office Box 2518 Pensacola, Florida 32513  
 (850) 484-6011 - Certificate of Authorization #00000155  
 Engineer of Record: David D. Skipper, P.E. #58972

|  |          |                      |
|--|----------|----------------------|
| STATE OF FLORIDA<br>DEPARTMENT OF TRANSPORTATION |          |                      |
| ROAD NO.   | COUNTY   | FINANCIAL PROJECT ID |
|  | ESCAMBIA | 430002-1-52-01       |

**CROSS SECTIONS**

SHEET NO.



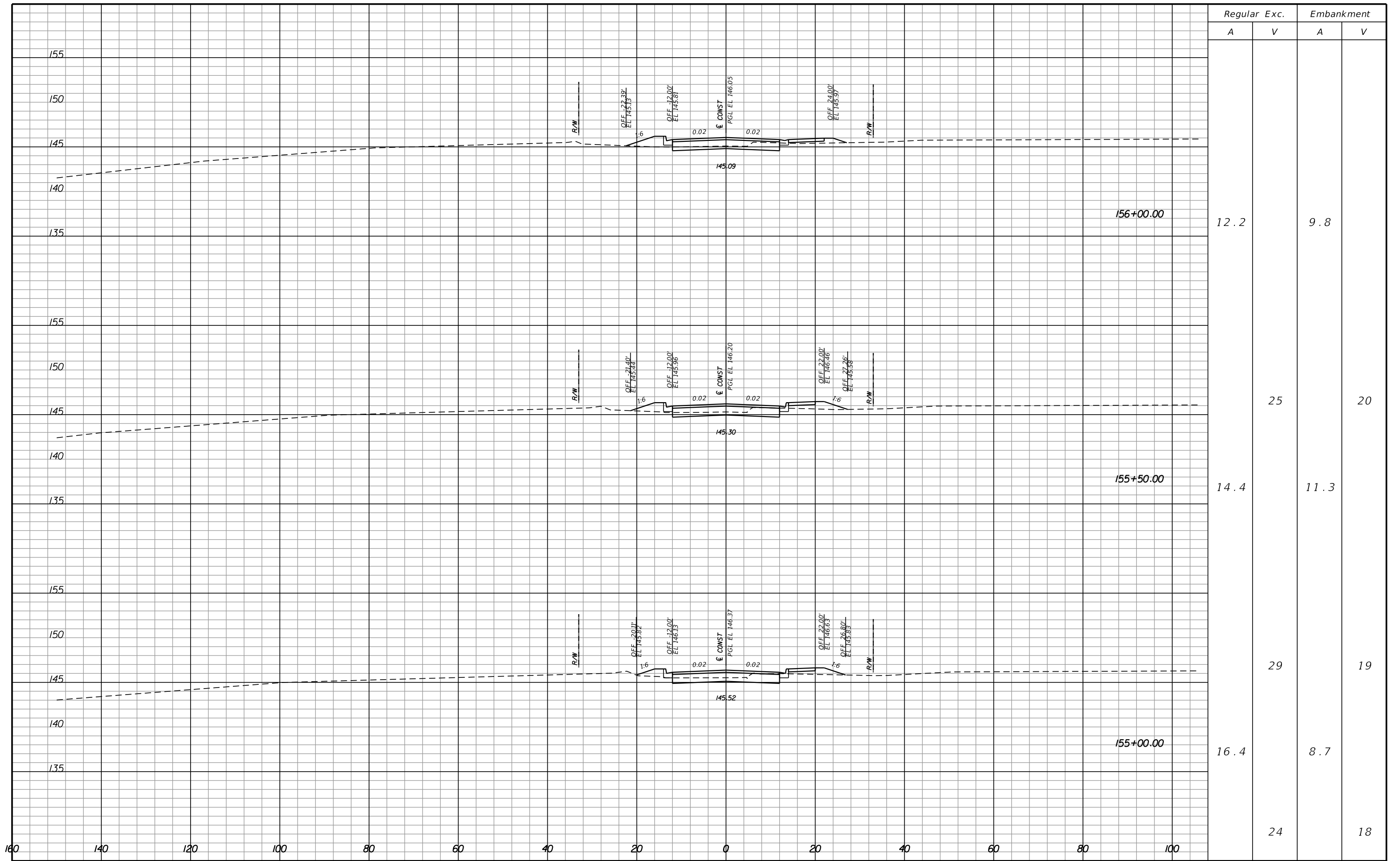

| Regular |    | Exc. |      | Embankment |    |
|---------|----|------|------|------------|----|
| A       | V  | A    | V    | A          | V  |
| 12.2    |    |      | 9.8  |            |    |
| 14.4    | 25 |      | 11.3 |            | 20 |
| 16.4    | 29 |      | 8.7  |            | 19 |
|         | 24 |      |      |            | 18 |

| REVISIONS |             |      |             |
|-----------|-------------|------|-------------|
| DATE      | DESCRIPTION | DATE | DESCRIPTION |
|           |             |      |             |

**Hatch Mott MacDonald**  
 Post Office Box 2518 Pensacola, Florida 32513  
 (850) 484-6011 - Certificate of Authorization #00000155  
 Engineer of Record: David D. Skipper, P.E. #58972

STATE OF FLORIDA  
 DEPARTMENT OF TRANSPORTATION

| ROAD NO. | COUNTY   | FINANCIAL PROJECT ID |
|----------|----------|----------------------|
|          | ESCAMBIA | 430002-1-52-01       |

**CROSS SECTIONS**

SHEET NO.

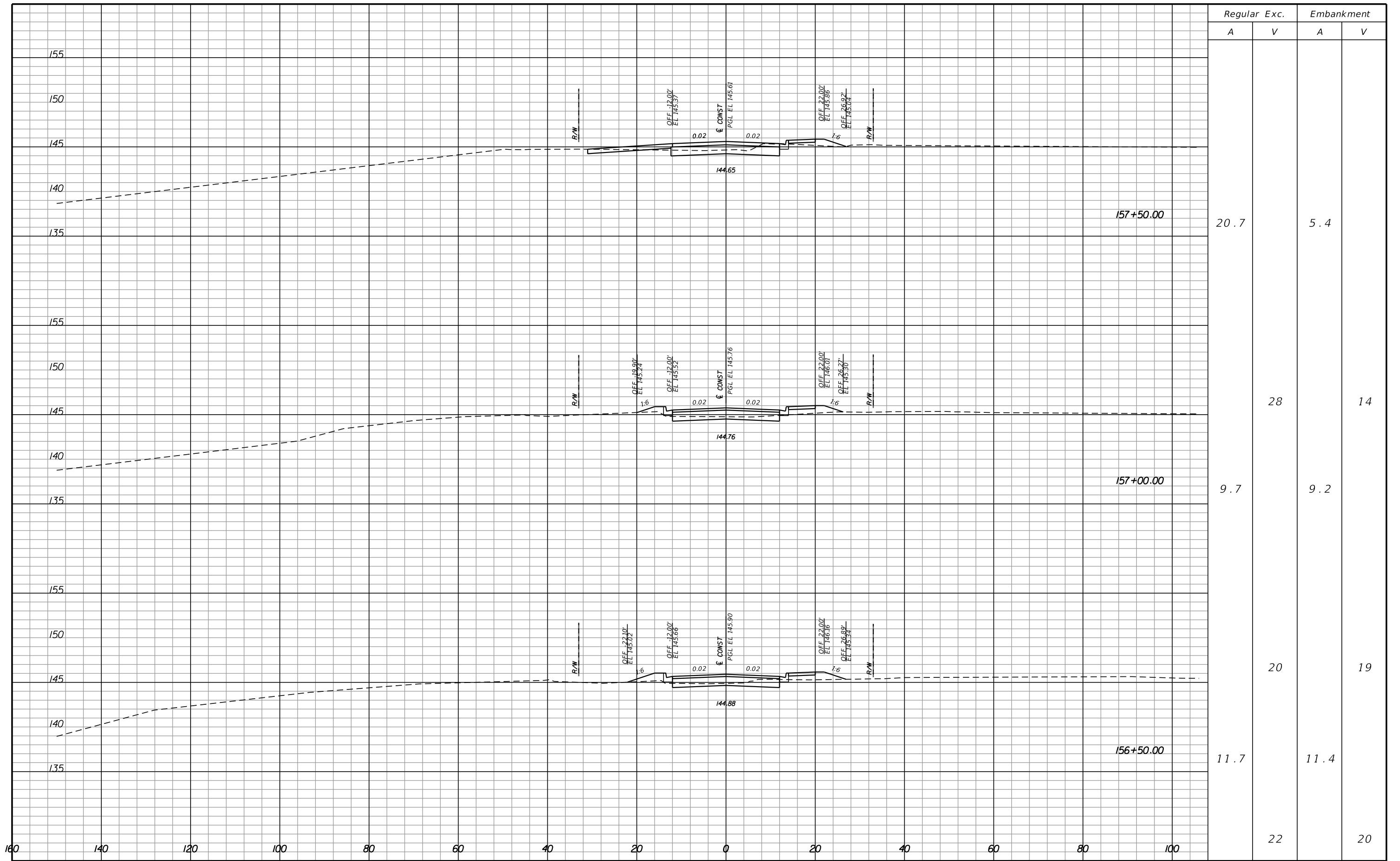

| Regular |    | Exc. |   | Embankment |    |
|---------|----|------|---|------------|----|
| A       | V  | A    | V | A          | V  |
| 20.7    |    |      |   | 5.4        |    |
| 9.7     |    | 28   |   | 9.2        | 14 |
| 11.7    |    | 20   |   | 11.4       | 19 |
|         | 22 |      |   |            | 20 |

| REVISIONS |             |      |             |
|-----------|-------------|------|-------------|
| DATE      | DESCRIPTION | DATE | DESCRIPTION |
|           |             |      |             |

**Hatch Mott MacDonald**  
 Post Office Box 2518 Pensacola, Florida 32513  
 (850) 484-6011 - Certificate of Authorization #00000155  
 Engineer of Record: David D. Skipper, P.E. #58972

STATE OF FLORIDA  
 DEPARTMENT OF TRANSPORTATION

| ROAD NO. | COUNTY   | FINANCIAL PROJECT ID |
|----------|----------|----------------------|
|          | ESCAMBIA | 430002-1-52-01       |

**CROSS SECTIONS**

SHEET NO.

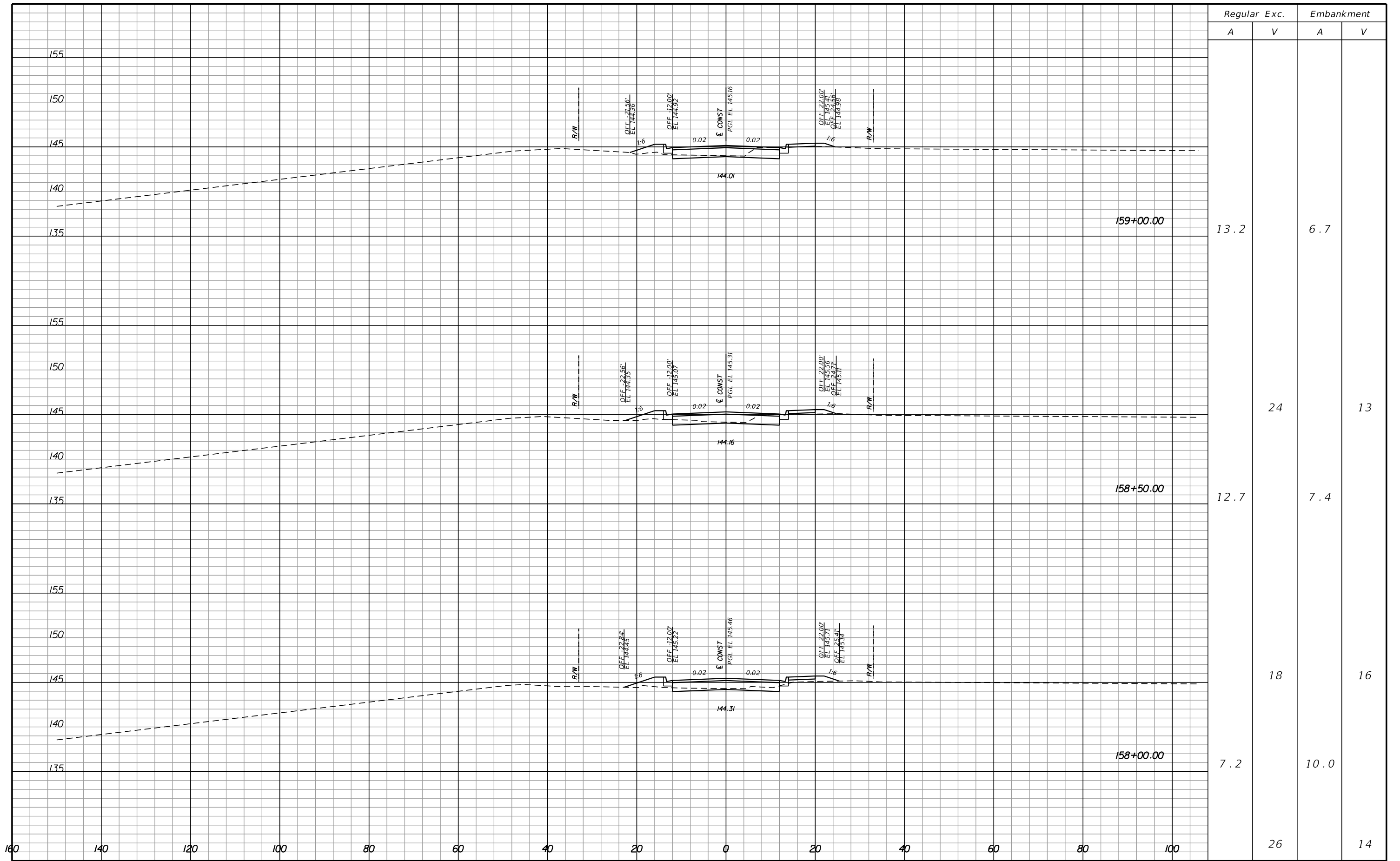

| Regular |    | Exc. |      | Embankment |    |
|---------|----|------|------|------------|----|
| A       | V  | A    | V    | A          | V  |
| 13.2    |    |      | 6.7  |            |    |
| 12.7    | 24 |      | 7.4  |            | 13 |
| 7.2     | 18 |      | 10.0 |            | 16 |
|         | 26 |      |      |            | 14 |

| REVISIONS |             |      |             |
|-----------|-------------|------|-------------|
| DATE      | DESCRIPTION | DATE | DESCRIPTION |
|           |             |      |             |

**Hatch Mott MacDonald**  
 Post Office Box 2518 Pensacola, Florida 32513  
 (850) 484-6011 - Certificate of Authorization #00000155  
 Engineer of Record: David D. Skipper, P.E. #58972

|  |          |                      |
|--|----------|----------------------|
| STATE OF FLORIDA<br>DEPARTMENT OF TRANSPORTATION |          |                      |
| ROAD NO.   | COUNTY   | FINANCIAL PROJECT ID |
|  | ESCAMBIA | 430002-1-52-01       |

**CROSS SECTIONS**

SHEET NO.

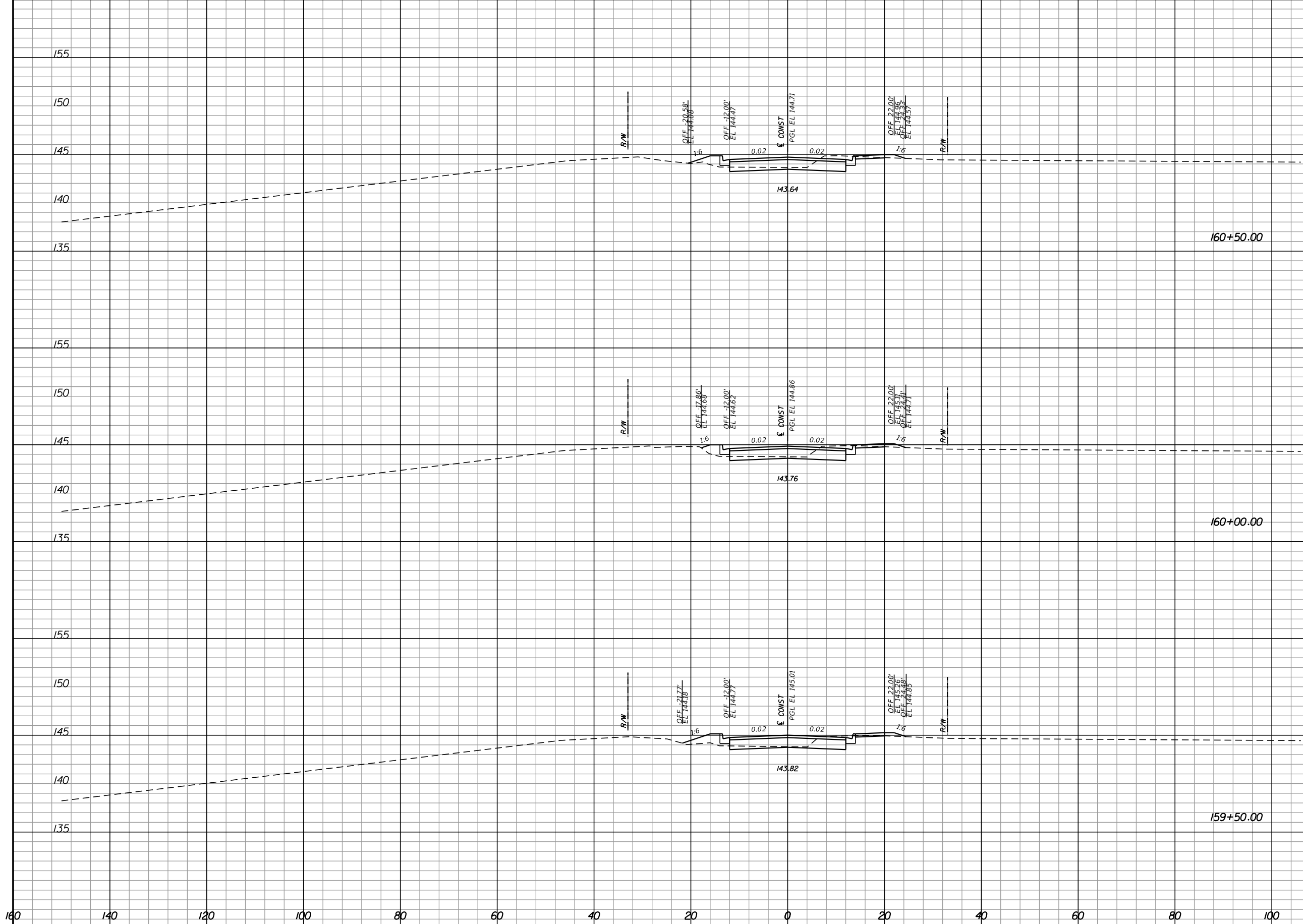

| Regular |    | Exc. |     | Embankment |    |
|---------|----|------|-----|------------|----|
| A       | V  | A    | V   | A          | V  |
| 17.7    |    |      | 5.1 |            |    |
| 16.6    | 32 | 4.5  |     | 9          |    |
| 14.0    | 28 | 6.9  |     | 11         |    |
|         | 25 |      |     |            | 13 |

| REVISIONS |             |      |             |
|-----------|-------------|------|-------------|
| DATE      | DESCRIPTION | DATE | DESCRIPTION |
|           |             |      |             |

**Hatch Mott MacDonald**  
 Post Office Box 2518 Pensacola, Florida 32513  
 (850) 484-6011 - Certificate of Authorization #00000155  
 Engineer of Record: David D. Skipper, P.E. #58972

|  |          |                      |
|--|----------|----------------------|
| STATE OF FLORIDA<br>DEPARTMENT OF TRANSPORTATION |          |                      |
| ROAD NO.   | COUNTY   | FINANCIAL PROJECT ID |
|  | ESCAMBIA | 430002-1-52-01       |

**CROSS SECTIONS**

SHEET NO.

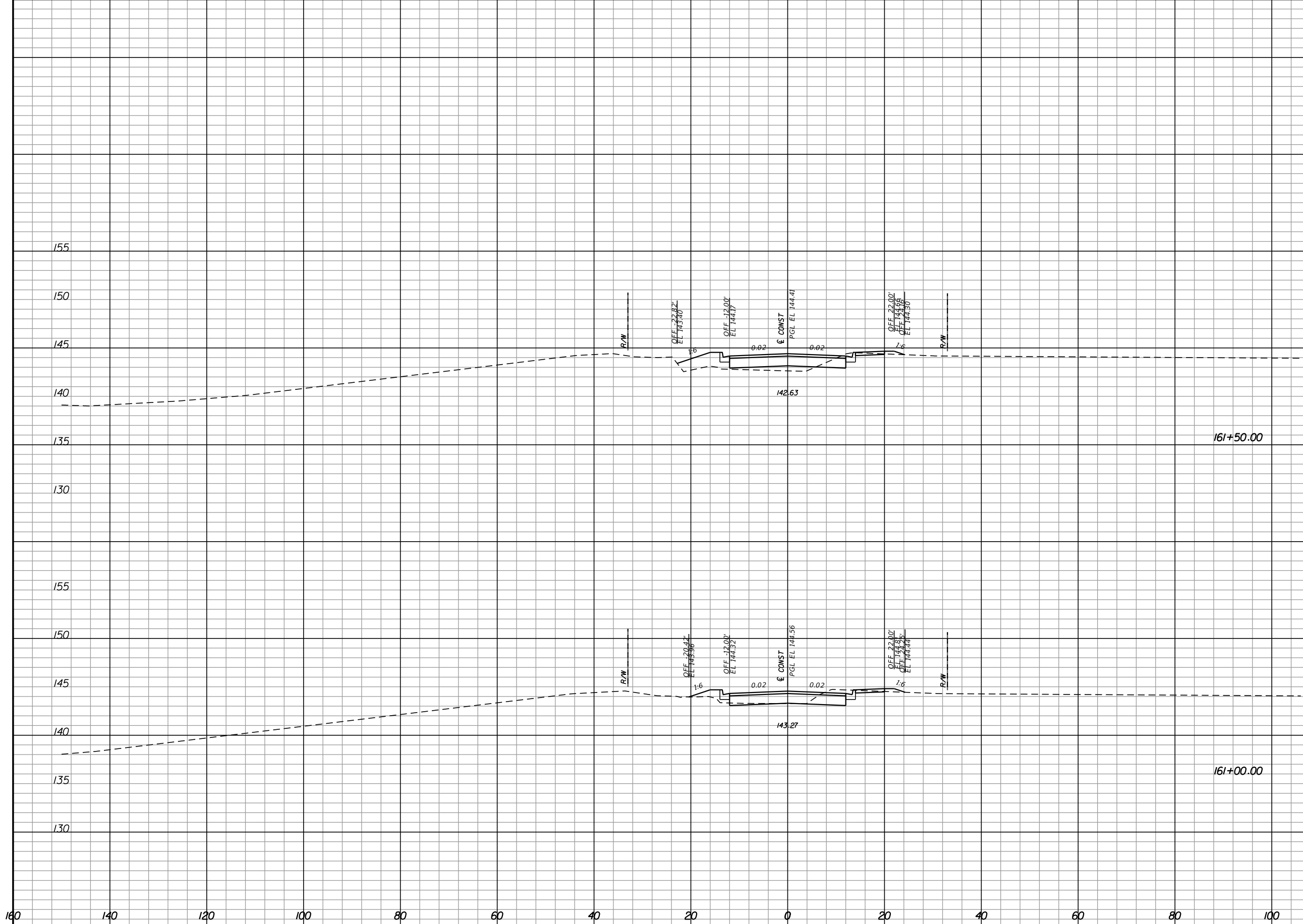

| Regular |    | Exc. |   | Embankment |    |
|---------|----|------|---|------------|----|
| A       | V  | A    | V | A          | V  |
| 7.4     |    |      |   | 19.3       |    |
|         | 19 |      |   |            | 23 |
| 13.6    |    |      |   | 5.2        |    |
|         | 29 |      |   |            | 10 |

| REVISIONS |             |      |             |
|-----------|-------------|------|-------------|
| DATE      | DESCRIPTION | DATE | DESCRIPTION |
|           |             |      |             |

**Hatch Mott MacDonald**  
 Post Office Box 2518 Pensacola, Florida 32513  
 (850) 484-6011 - Certificate of Authorization #00000155  
 Engineer of Record: David D. Skipper, P.E. #58972

STATE OF FLORIDA  
 DEPARTMENT OF TRANSPORTATION

| ROAD NO. | COUNTY   | FINANCIAL PROJECT ID |
|----------|----------|----------------------|
|          | ESCAMBIA | 430002-1-52-01       |

**CROSS SECTIONS**

SHEET NO.





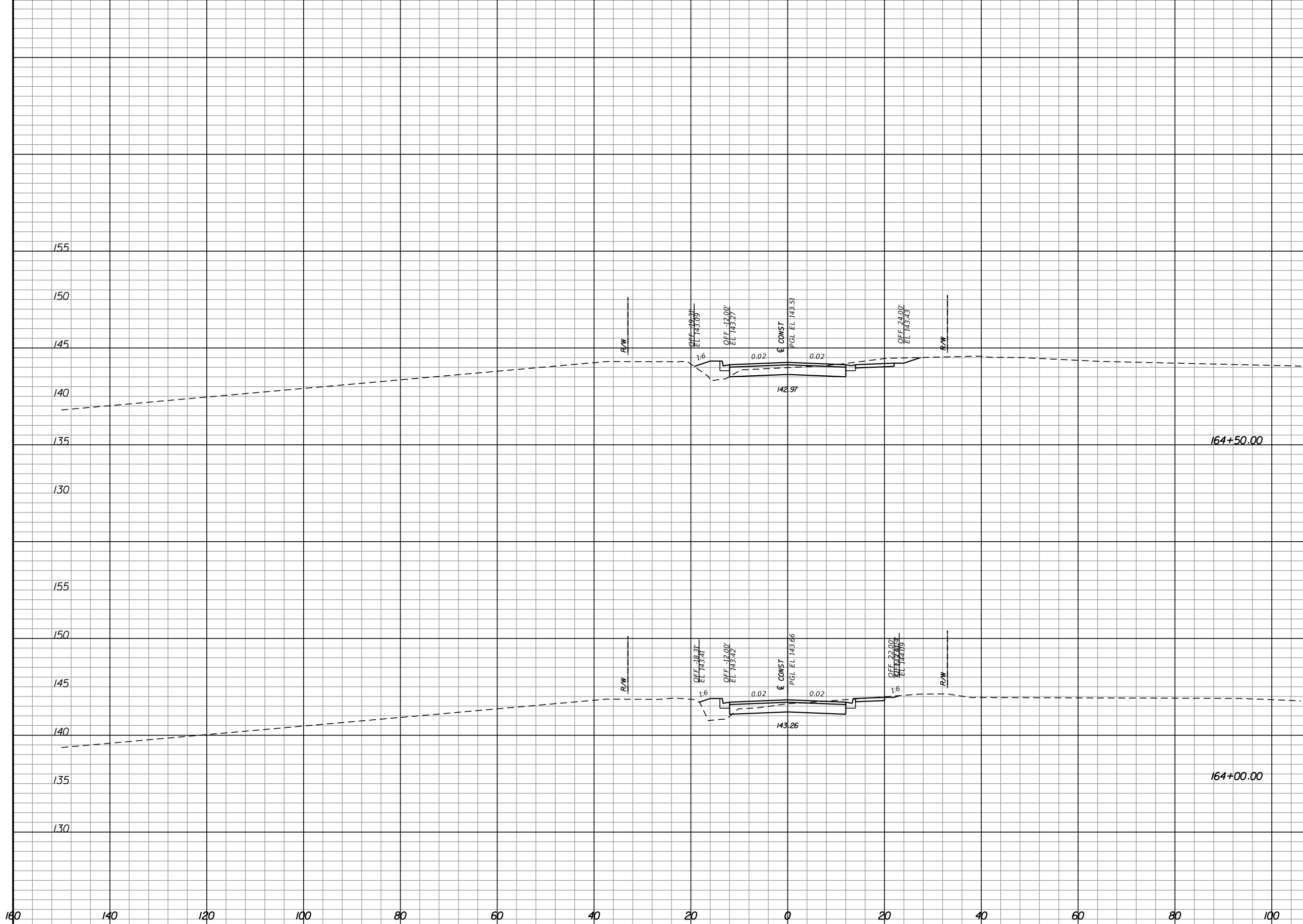

| Station   | Regular Exc. |    | Embankment |    |
|-----------|--------------|----|------------|----|
|           | A            | V  | A          | V  |
| 164+50.00 | 29.1         |    | 8.4        |    |
| 164+00.00 | 24.9         | 50 | 9.5        | 17 |
|           |              | 42 |            | 18 |

| REVISIONS |             |      |             |
|-----------|-------------|------|-------------|
| DATE      | DESCRIPTION | DATE | DESCRIPTION |
|           |             |      |             |

**Hatch Mott MacDonald**  
 Post Office Box 2518 Pensacola, Florida 32513  
 (850) 484-6011 - Certificate of Authorization #00000155  
 Engineer of Record: David D. Skipper, P.E. #58972

| STATE OF FLORIDA<br>DEPARTMENT OF TRANSPORTATION |          |                      |
|--|----------|----------------------|
| ROAD NO.   | COUNTY   | FINANCIAL PROJECT ID |
|  | ESCAMBIA | 430002-1-52-01       |

**CROSS SECTIONS**

|           |
|-----------|
| SHEET NO. |
|-----------|





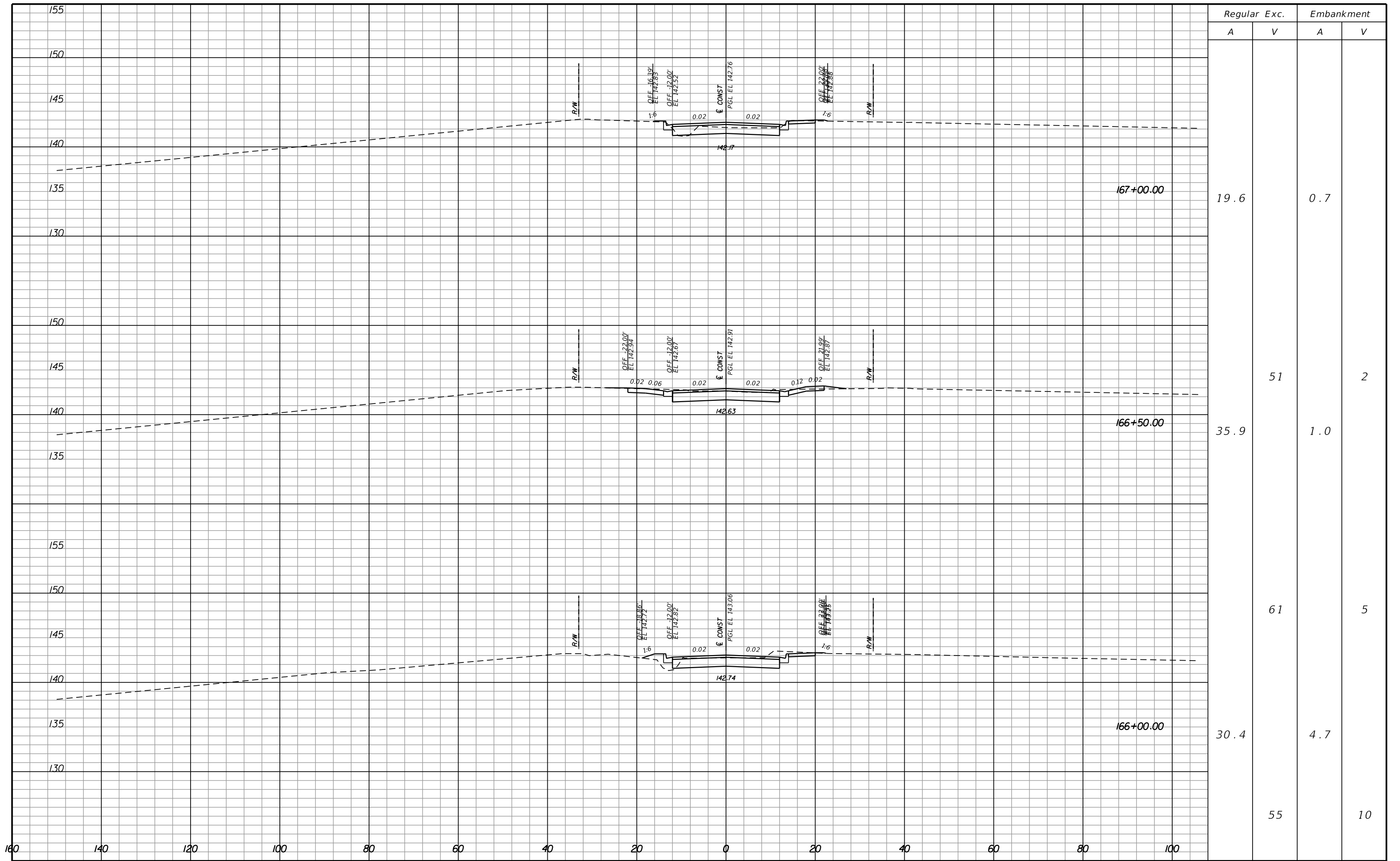

| REVISIONS |             |      |             |
|-----------|-------------|------|-------------|
| DATE      | DESCRIPTION | DATE | DESCRIPTION |
|           |             |      |             |

**Hatch Mott MacDonald**  
 Post Office Box 2518 Pensacola, Florida 32513  
 (850) 484-6011 - Certificate of Authorization #00000155  
 Engineer of Record: David D. Skipper, P.E. #58972

STATE OF FLORIDA  
 DEPARTMENT OF TRANSPORTATION

|          |          |                      |
|----------|----------|----------------------|
| ROAD NO. | COUNTY   | FINANCIAL PROJECT ID |
|          | ESCAMBIA | 430002-1-52-01       |

**CROSS SECTIONS**

SHEET NO.

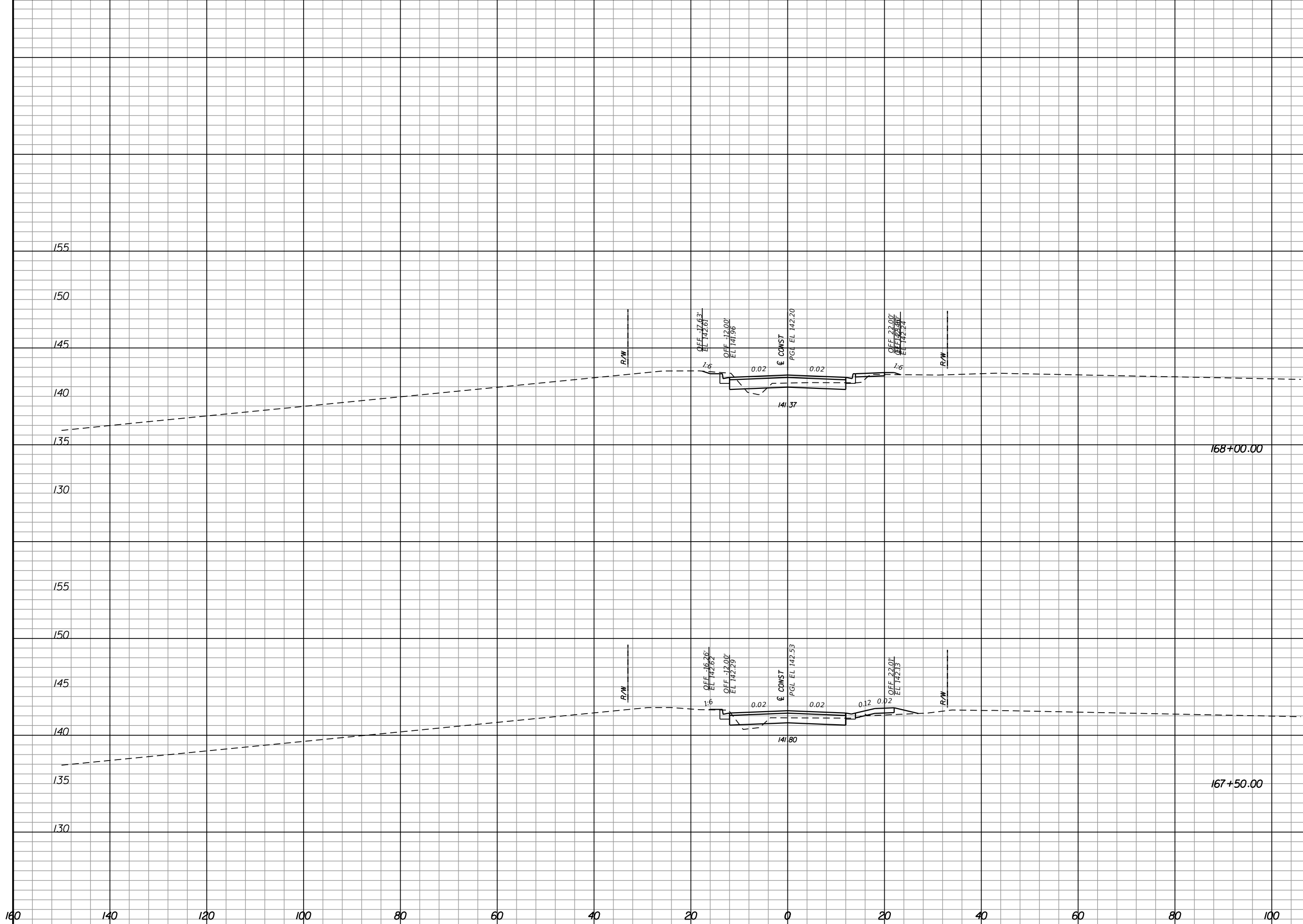

| Regular Exc. |    | Embankment |   |
|--------------|----|------------|---|
| A            | V  | A          | V |
| 14.8         |    | 3.7        |   |
|              | 26 |            | 8 |
| 13.5         |    | 4.8        |   |
|              | 31 |            | 5 |

| REVISIONS |             |      |             |
|-----------|-------------|------|-------------|
| DATE      | DESCRIPTION | DATE | DESCRIPTION |
|           |             |      |             |

**Hatch Mott MacDonald**  
 Post Office Box 2518 Pensacola, Florida 32513  
 (850) 484-6011 - Certificate of Authorization #00000155  
 Engineer of Record: David D. Skipper, P.E. #58972

|  |          |                      |
|--|----------|----------------------|
| STATE OF FLORIDA<br>DEPARTMENT OF TRANSPORTATION |          |                      |
| ROAD NO.   | COUNTY   | FINANCIAL PROJECT ID |
|  | ESCAMBIA | 430002-1-52-01       |

**CROSS SECTIONS**

SHEET NO.

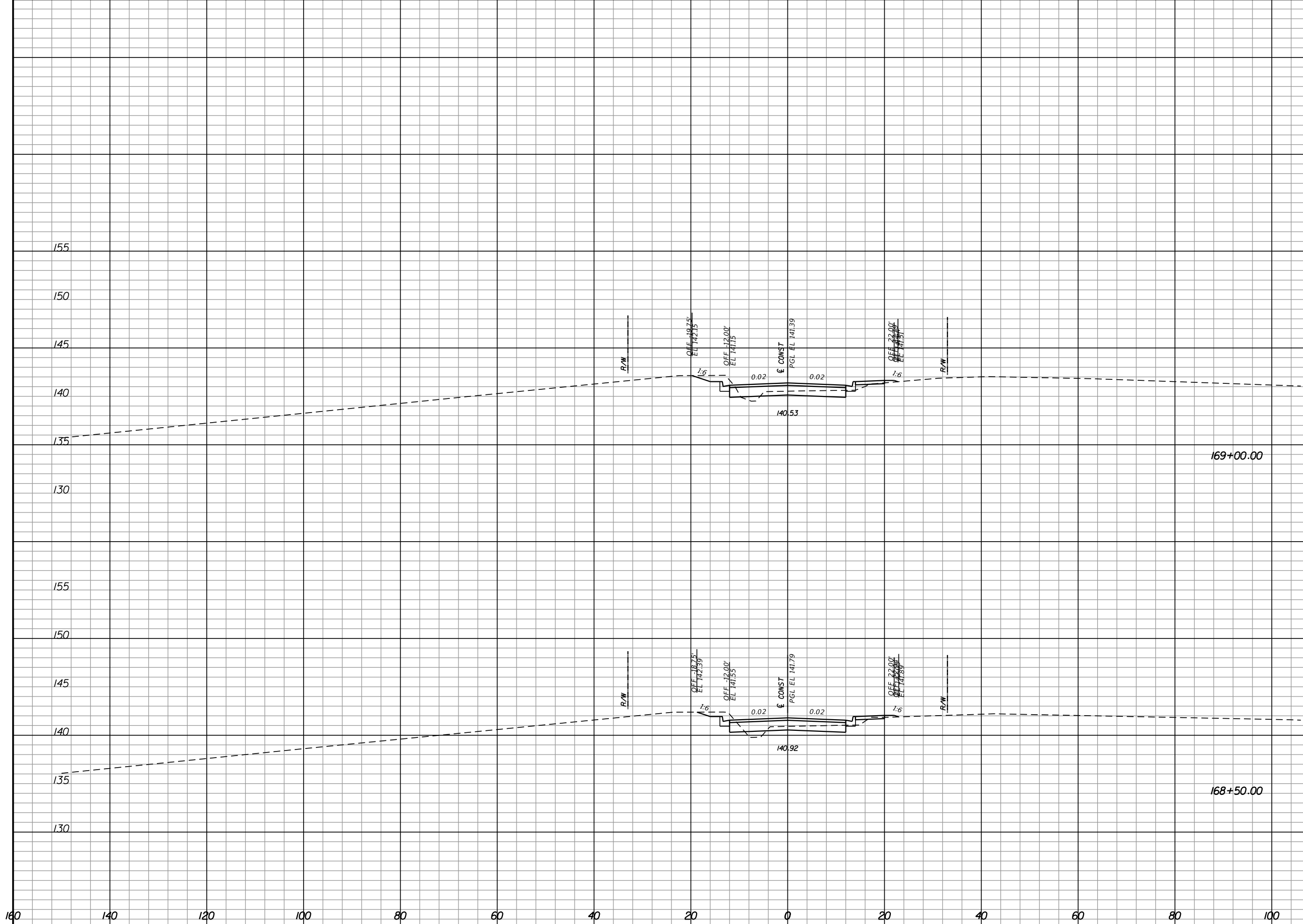

| Regular |    | Exc. |   | Embankment |   |
|---------|----|------|---|------------|---|
| A       | V  | A    | V | A          | V |
|         |    |      |   |            |   |
| 17.1    |    | 2.6  |   |            |   |
|         | 31 |      |   |            | 6 |
| 16.3    |    | 3.5  |   |            |   |
|         | 29 |      |   |            | 7 |

| REVISIONS |             |      |             |
|-----------|-------------|------|-------------|
| DATE      | DESCRIPTION | DATE | DESCRIPTION |
|           |             |      |             |

**Hatch Mott MacDonald**  
 Post Office Box 2518 Pensacola, Florida 32513  
 (850) 484-6011 - Certificate of Authorization #00000155  
 Engineer of Record: David D. Skipper, P.E. #58972

STATE OF FLORIDA  
 DEPARTMENT OF TRANSPORTATION

|          |          |                      |
|----------|----------|----------------------|
| ROAD NO. | COUNTY   | FINANCIAL PROJECT ID |
|          | ESCAMBIA | 430002-1-52-01       |

**CROSS SECTIONS**

SHEET NO.

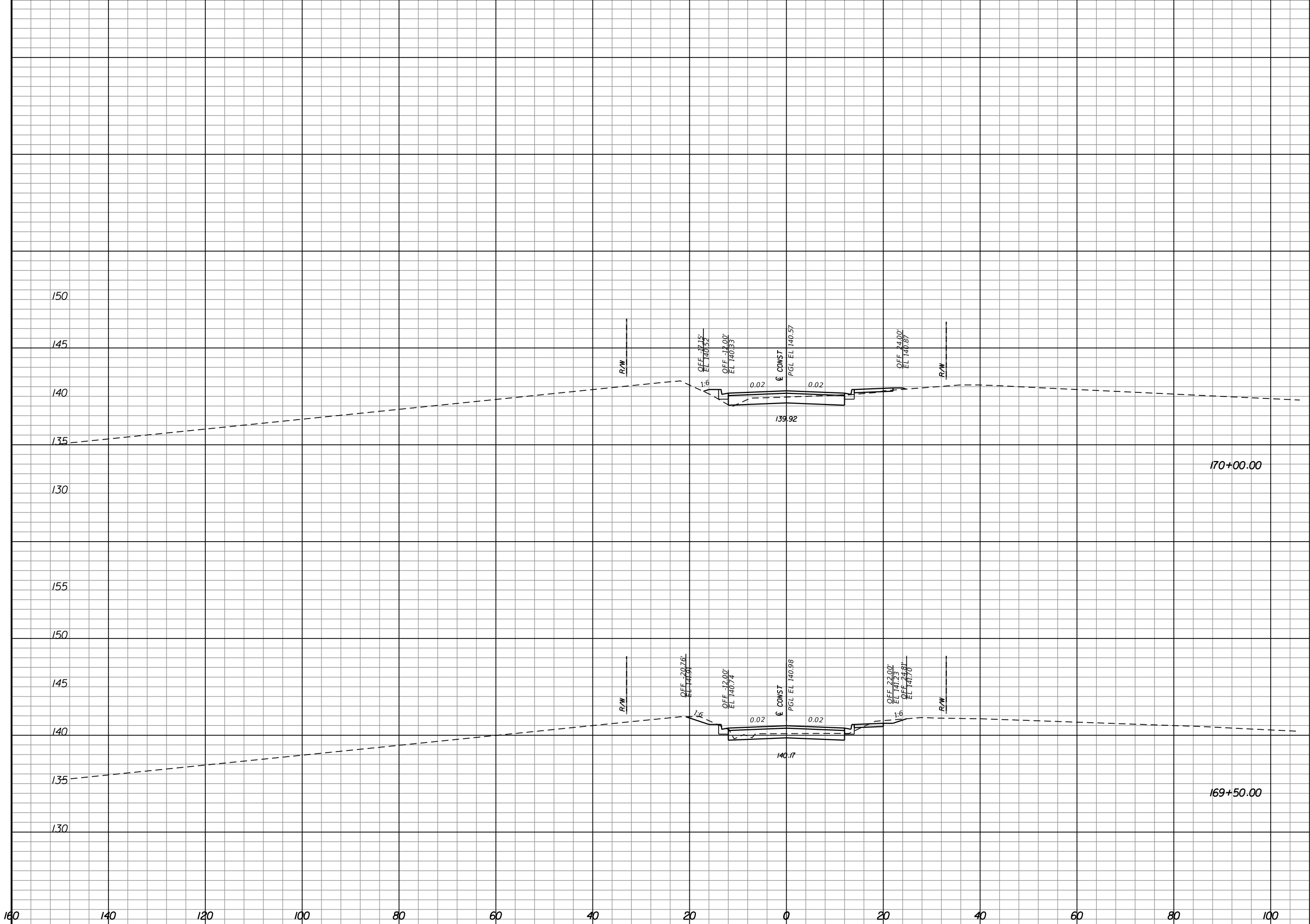

| Regular |    | Exc. |     | Embankment |   |
|---------|----|------|-----|------------|---|
| A       | V  | A    | V   | A          | V |
| 16.8    |    |      |     | 3.4        |   |
|         | 33 |      |     |            | 3 |
| 18.7    |    |      | 0.3 |            |   |
|         | 33 |      |     |            | 3 |

| REVISIONS |             |      |             |
|-----------|-------------|------|-------------|
| DATE      | DESCRIPTION | DATE | DESCRIPTION |
|           |             |      |             |



**Hatch Mott MacDonald**  
 Post Office Box 2518 Pensacola, Florida 32513  
 (850) 484-6011 - Certificate of Authorization #00000155  
 Engineer of Record: David D. Skipper, P.E. \*58972

| STATE OF FLORIDA<br>DEPARTMENT OF TRANSPORTATION |          |                      |
|--|----------|----------------------|
| ROAD NO.   | COUNTY   | FINANCIAL PROJECT ID |
|  | ESCAMBIA | 430002-1-52-01       |

**CROSS SECTIONS**

| SHEET NO. |
|-----------|
|           |

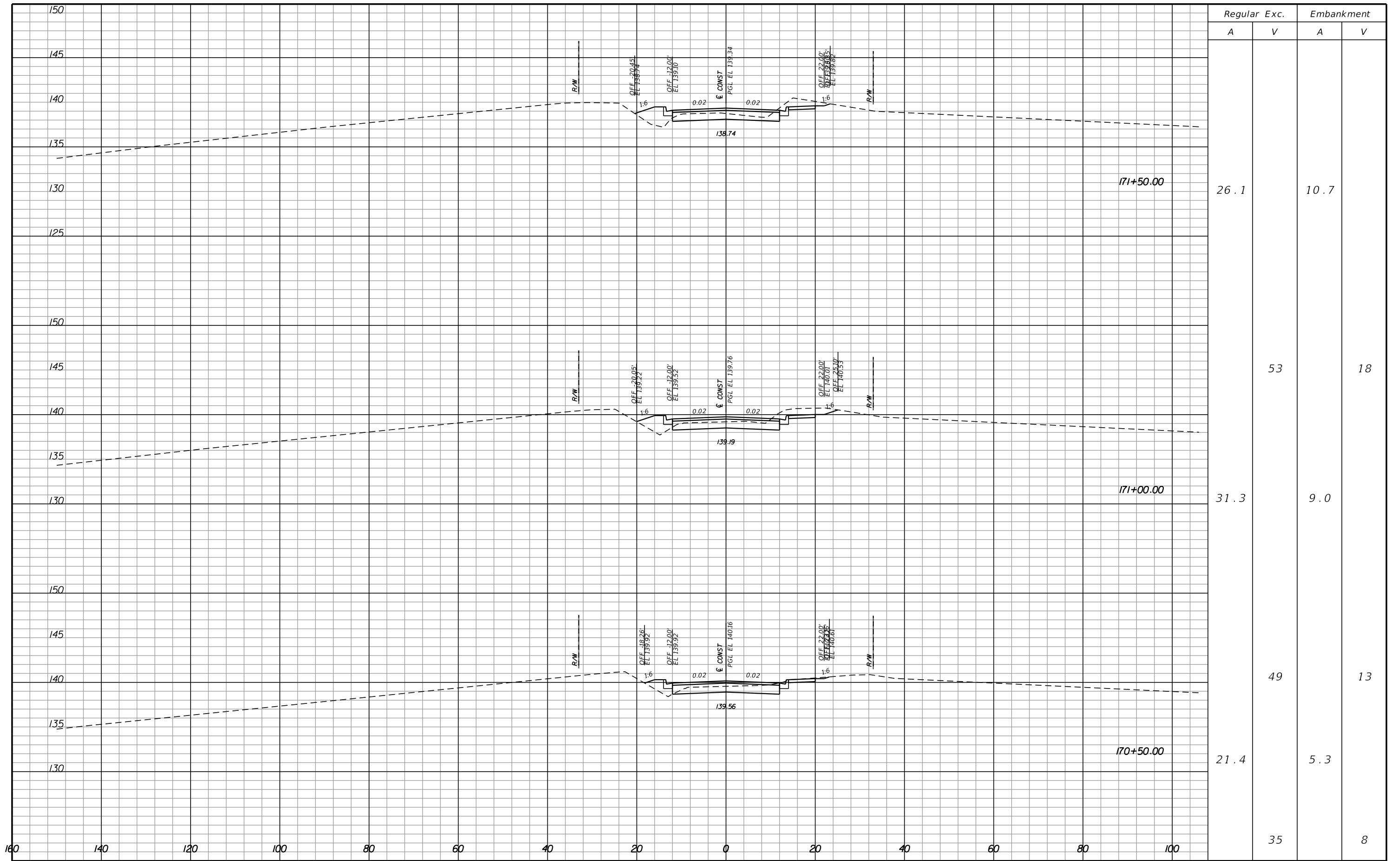

| Regular |    | Exc. |    | Embankment |    |
|---------|----|------|----|------------|----|
| A       | V  | A    | V  | A          | V  |
| 26.1    |    |      |    | 10.7       |    |
| 31.3    |    |      | 53 | 9.0        | 18 |
| 21.4    |    |      | 49 | 5.3        | 13 |
|         | 35 |      |    |            | 8  |

| REVISIONS |             |      |             |
|-----------|-------------|------|-------------|
| DATE      | DESCRIPTION | DATE | DESCRIPTION |
|           |             |      |             |

**Hatch Mott MacDonald**  
 Post Office Box 2518 Pensacola, Florida 32513  
 (850) 484-6011 - Certificate of Authorization #00000155  
 Engineer of Record: David D. Skipper, P.E. #58972

|  |          |                      |
|--|----------|----------------------|
| STATE OF FLORIDA<br>DEPARTMENT OF TRANSPORTATION |          |                      |
| ROAD NO.   | COUNTY   | FINANCIAL PROJECT ID |
|  | ESCAMBIA | 430002-1-52-01       |

**CROSS SECTIONS**

SHEET NO.

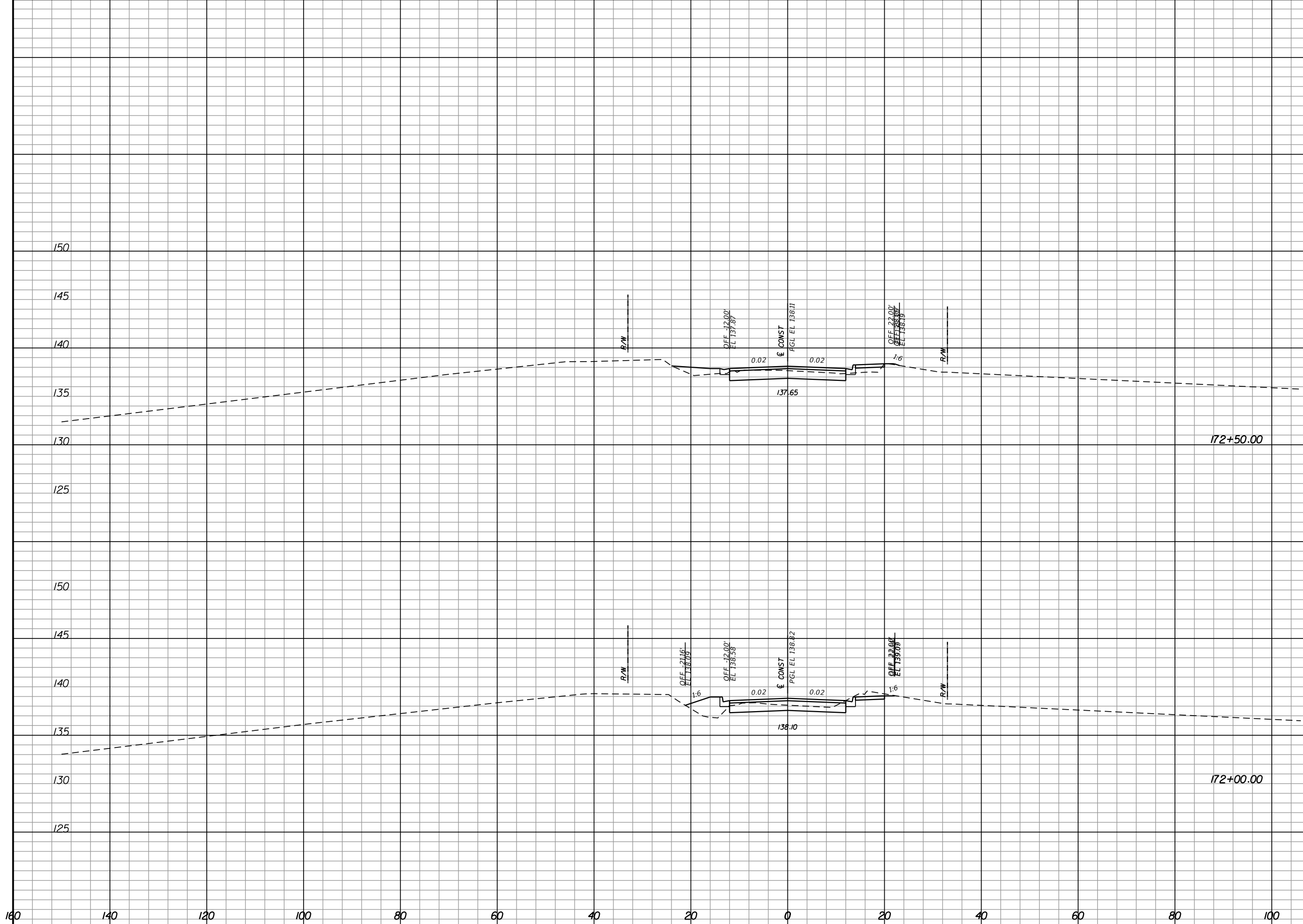

| Regular |   | Exc. |     | Embankment |    |
|---------|---|------|-----|------------|----|
| A       | V | A    | V   | A          | V  |
|         |   |      |     |            |    |
|         |   |      |     |            |    |
| 21.0    |   |      | 8.0 |            |    |
|         |   |      |     |            |    |
|         |   |      |     |            |    |
|         |   |      |     |            |    |
|         |   |      | 40  |            | 18 |
|         |   |      |     |            |    |
| 22.6    |   |      |     | 11.1       |    |
|         |   |      |     |            |    |
|         |   |      |     |            |    |
|         |   |      | 45  |            | 20 |

| REVISIONS |             |      |             |
|-----------|-------------|------|-------------|
| DATE      | DESCRIPTION | DATE | DESCRIPTION |
|           |             |      |             |



|  |          |                      |
|--|----------|----------------------|
| STATE OF FLORIDA<br>DEPARTMENT OF TRANSPORTATION |          |                      |
| ROAD NO.   | COUNTY   | FINANCIAL PROJECT ID |
|  | ESCAMBIA | 430002-1-52-01       |

CROSS SECTIONS

SHEET  
NO.

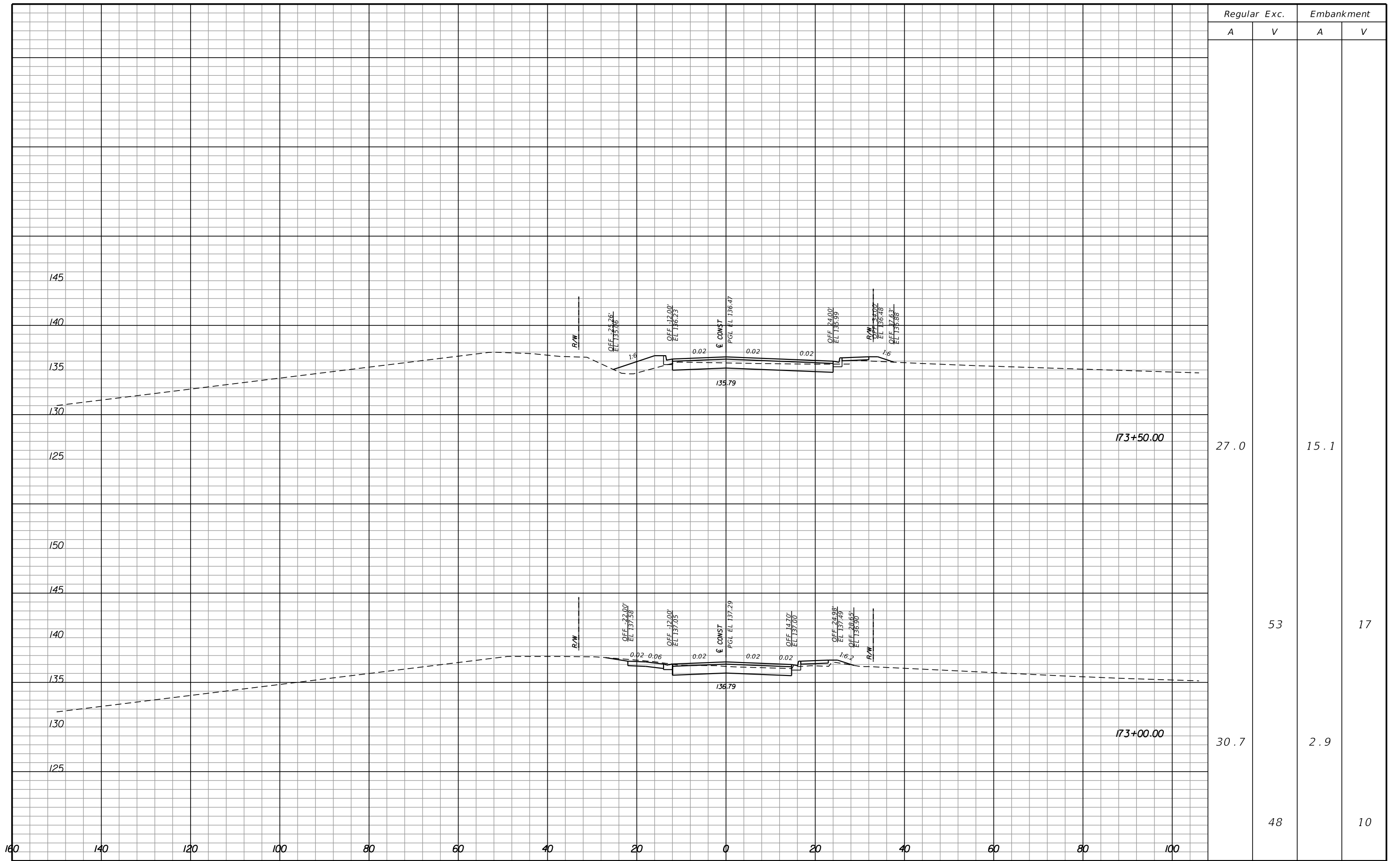

| Regular Exc. |    | Embankment |    |
|--------------|----|------------|----|
| A            | V  | A          | V  |
| 27.0         |    | 15.1       |    |
| 30.7         | 53 | 2.9        | 17 |
|              | 48 |            | 10 |

| REVISIONS |             |      |             |
|-----------|-------------|------|-------------|
| DATE      | DESCRIPTION | DATE | DESCRIPTION |
|           |             |      |             |

**Hatch Mott MacDonald**  
 Post Office Box 2518 Pensacola, Florida 32513  
 (850) 484-6011 - Certificate of Authorization #00000155  
 Engineer of Record: David D. Skipper, P.E. #58972

|  |          |                      |
|--|----------|----------------------|
| STATE OF FLORIDA<br>DEPARTMENT OF TRANSPORTATION |          |                      |
| ROAD NO.   | COUNTY   | FINANCIAL PROJECT ID |
|  | ESCAMBIA | 430002-1-52-01       |

**CROSS SECTIONS**

SHEET NO.



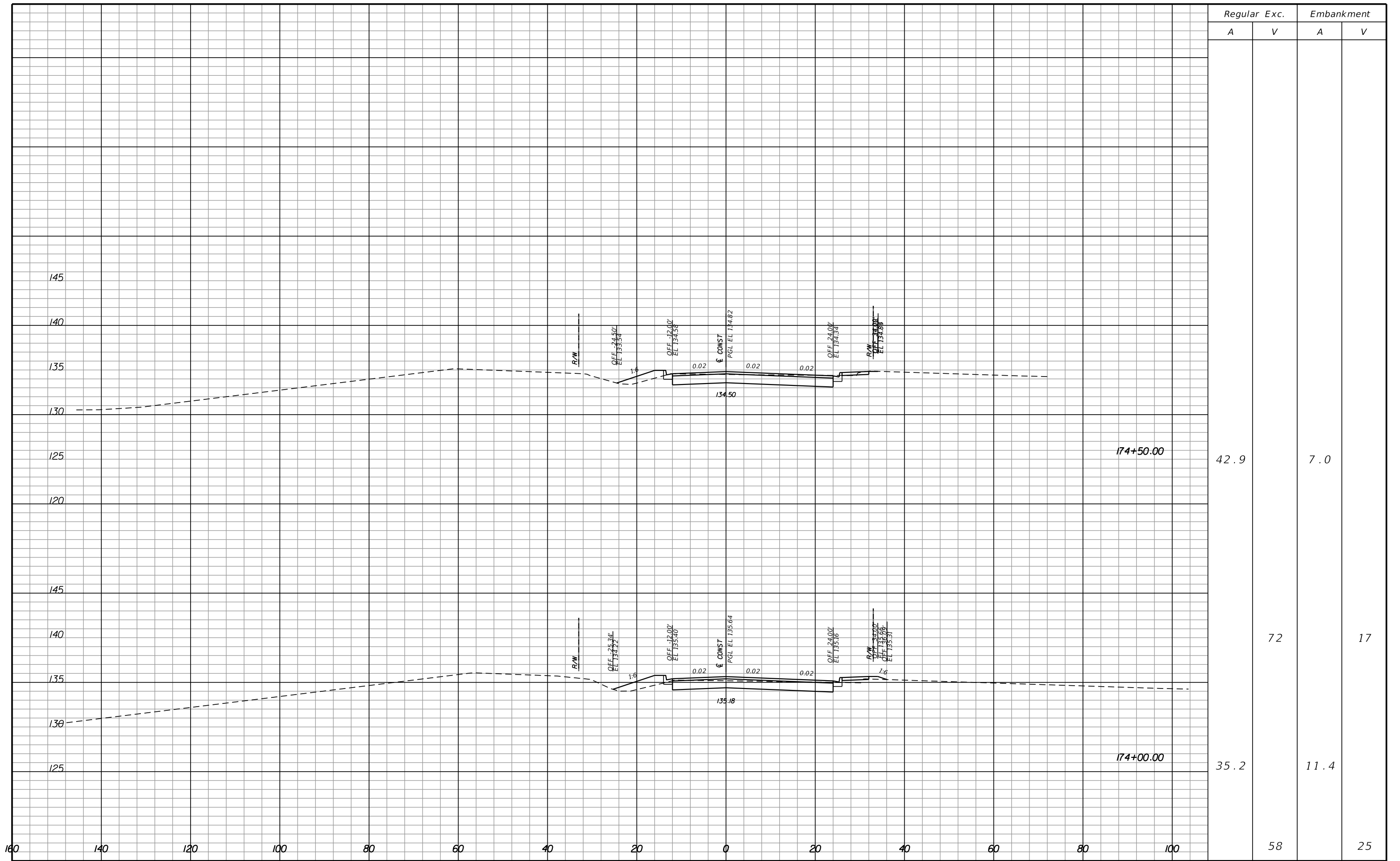

| REVISIONS |             |      |             |
|-----------|-------------|------|-------------|
| DATE      | DESCRIPTION | DATE | DESCRIPTION |
|           |             |      |             |



**Hatch Mott  
MacDonald**  
Post Office Box 2518 Pensacola, Florida 32513  
(850) 484-6011 - Certificate of Authorization #00000155  
Engineer of Record: David D. Skipper, P.E. #58972

| STATE OF FLORIDA<br>DEPARTMENT OF TRANSPORTATION |          |                      |
|--|----------|----------------------|
| ROAD NO.   | COUNTY   | FINANCIAL PROJECT ID |
|  | ESCAMBIA | 430002-1-52-01       |

**CROSS SECTIONS**

SHEET NO.

| Regular Exc. |       | Embankment |       |
|--------------|-------|------------|-------|
| A            | V     | A          | V     |
|              |       |            |       |
|              | 86968 |            | 57522 |

EARTHWORK SUMMARY  
TOTAL EXCAVATION 86968 CY  
TOTAL EMBANKMENT 57522 CY

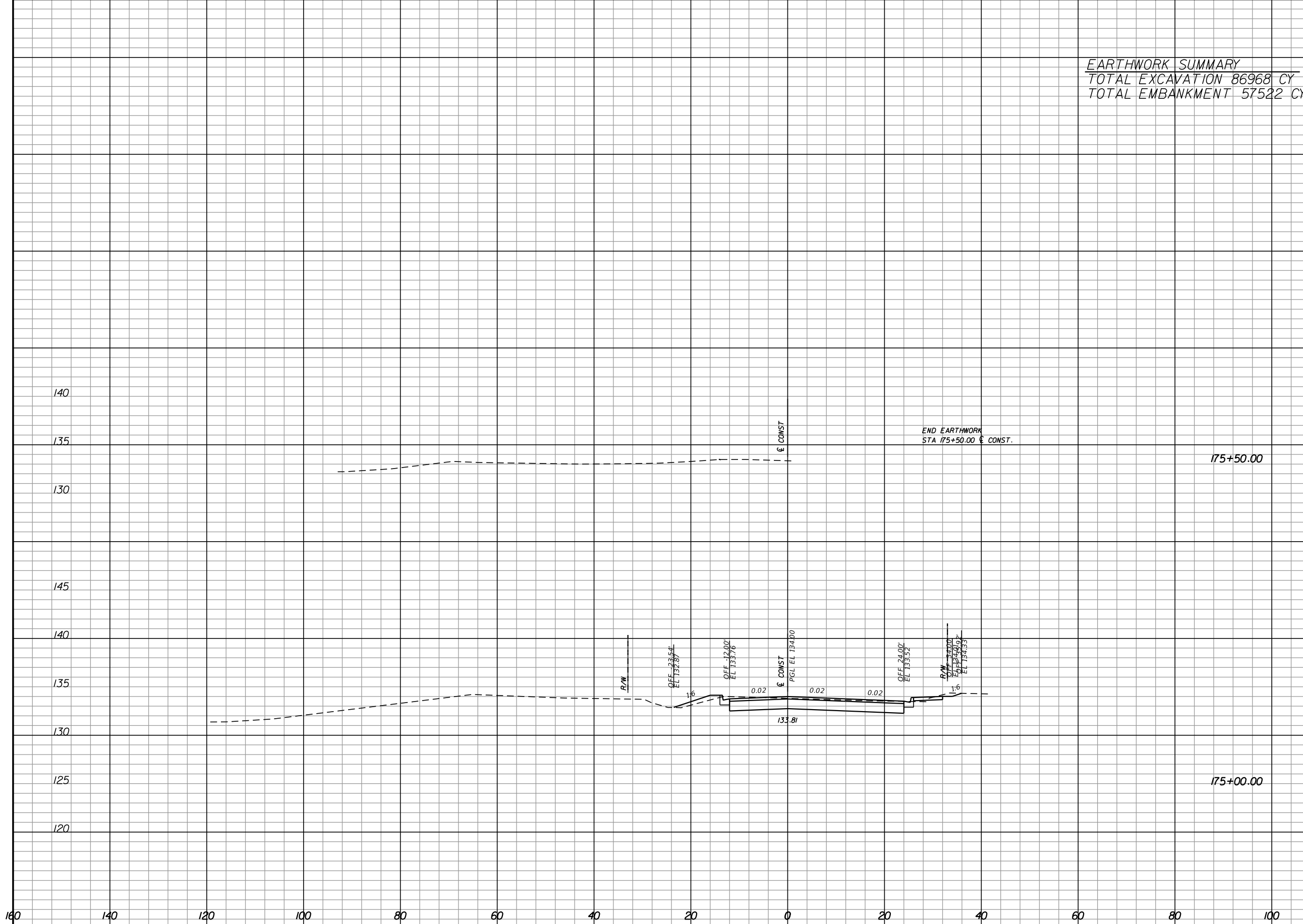

|      |     |   |    |
|------|-----|---|----|
| 0.0  | 0.0 |   |    |
| 44   | 44  | 3 | 3  |
| 47.2 | 3.6 |   |    |
| 83   |     |   | 10 |

| REVISIONS |             |      |             |
|-----------|-------------|------|-------------|
| DATE      | DESCRIPTION | DATE | DESCRIPTION |
|           |             |      |             |

**Hatch Mott MacDonald**  
Post Office Box 2518 Pensacola, Florida 32513  
(850) 484-6011 - Certificate of Authorization #00000155  
Engineer of Record: David D. Skipper, P.E. #58972

| STATE OF FLORIDA<br>DEPARTMENT OF TRANSPORTATION |          |                      |
|--|----------|----------------------|
| ROAD NO.   | COUNTY   | FINANCIAL PROJECT ID |
|  | ESCAMBIA | 430002-1-52-01       |

**CROSS SECTIONS**

SHEET NO.