

P.O. Box 11399 • 32524-1399 Pensacola, FL | 4081 E. Olive Road-Suite A • 32514
P: 850.332.7976 • 1.800.226.8914 • F: 850.637.1923 | www.wfrpc.org

TRANSPORTATION PLANNING ORGANIZATION MEETINGS
PLEASE NOTE TPO, TCC AND CAC MEETING DATES AND LOCATIONS

Monday, April 8, 2019

Technical Coordinating Committee (TCC)- 8:30 a.m.
Pensacola City Hall, 222 West Main Street, Pensacola, Florida

Tuesday, April 9, 2019 **NEW DATE AND TIME

Citizens' Advisory Committee (CAC)- 3:00 p.m.
Pensacola City Hall, 222 West Main Street, Pensacola, Florida

Wednesday, April 10, 2019

Transportation Planning Organization (TPO) Board-9:00 a.m.
Tiger Point Community Center, 1370 Tiger Point Lane, Gulf Breeze, Florida

- A. **CALL TO ORDER / PLEDGE / INVOCATION-** *Chairman Jeff Bergosh*
- B. **APPROVAL OF AGENDA**
Any new action items to be added to the agenda must be approved by a vote of two thirds (2/3) of the TPO members present.
- C. **PUBLIC FORUM:**
Please obtain a speaker request form from ECRC staff. Speakers are asked to limit their remarks to five minutes.
- D. **FDOT/ALDOT UPDATES:**
 - 1. **FDOT UPDATE:** *Mr. Bryant Paulk, AICP, or Ms. Christy Johnson, AICP, Florida Department of Transportation (FDOT) Urban Liaisons*
 - 2. **ALDOT UPDATE:** *Mr. Vincent Beebe, P.E., Alabama Department of Transportation (ALDOT)*
- E. **CONSENT:**
 - 1. **ALL COMMITTEES:** Approval of February 2019 Meeting Minutes

F. ACTION:

1. **ENCLOSURE A- ALL COMMITTEES** Request to Proceed with Amending the Florida-Alabama 2040 Long Range Transportation Plan for Two Projects: (1) I-10 from Avalon Boulevard to Okaloosa County Line and (2) I-10 at Beulah Road Interchange-*Mr. Gary Kramer, ECRC Staff*
2. **ENCLOSURE B- TPO AND TCC ONLY:** Approval to Issue a Request for Qualifications for General Traffic Engineering Operation and Management Services and Establish a Selection Review Committee - *Mr. Austin Mount, ECRC Executive Director*
3. **ENCLOSURE C- ALL COMMITTEES** Consideration of Resolution FL-AL 19-06 Adopting the FY 2019-FY 2020 Unified Planning Work Program (UPWP) Year 2 (FY 2020) Amendments, Authorizing the TPO Chairman to Sign the Certifications and Assurances and Authorizing TPO Staff to Apply for and Execute a Federal Transit Administration FTA Section 5305 Grant for Use- *Ms. Mary Beth Washnock, ECRC Transportation Planning Manager*
4. **ENCLOSURE D- ALL COMMITTEES** Appointment of Nominating Committee for the Election of Florida-Alabama Transportation Planning Organization (TPO) and Advisory Committee Chairman and Vice-Chairman for Fiscal Year (FY) 2020- *Ms. Tiffany Bates, ECRC Staff*
5. **ENCLOSURE E- TPO ONLY** Consideration of Appointing an Escambia County Member as an Alternate to the Northwest Florida Regional Transportation Planning Organization (RTPO)- *Ms. Tiffany Bates, ECRC Staff*

G. EMERALD COAST REGIONAL COUNCIL EXECUTIVE DIRECTOR'S REPORT- TPO ONLY- Mr. Austin Mount, ECRC Executive Director

H. MULTI MODAL UPDATE

1. **ENCLOSURE F- ALL COMMITTEES** Status Update on of the Escambia County Area Transit (ECAT) Bus Stop Assessment Plan- *Mr. Rob Mahan, ECRC Staff*

I. PRESENTATIONS (no action):

1. **ENCLOSURE G- TPO AND TCC ONLY** Update on the Escambia/Santa Rosa Regional Advanced Traffic Management System (ATMS) Feasibility Study and Implementation Plan, and Traffic Signalization Tasks of the Existing Joint Project Agreement (JPA)- *Mr. Ben Faust, DRMP*
2. **ENCLOSURE H- ALL COMMITTEES** Review of the Draft FL-AL TPO FY 2020-2024 Transportation Improvement Program (TIP)- *Mr. Gary Kramer, ECRC Staff*

3. **ENCLOSURE I- ALL COMMITTEES** Overview of the Florida-Alabama TPO FY 2021-2025 Project Priorities Process and Schedule-*Mr. Gary Kramer, ECRC Staff*
4. **ENCLOSURE J- ALL COMMITTEES** Review of the Draft Florida-Alabama Transportation Planning Organization (FL-AL TPO) Public Participation Plan (PPP) Major Update- *Ms. Brittany Ellers, ECRC Staff*
5. **ENCLOSURE K- ALL COMMITTEES** Fifth Annual Emerald Coast Transportation Symposium Update- *Ms. Brittany Ellers, ECRC Staff*

J. INFORMATION ITEMS (no presentation necessary)

1. **ENCLOSURE L- ALL COMMITTEES**

- TCC and CAC February Meeting Minutes
- FL-AL TPO February Actions Report
- FDOT Changes to the Tentative Work Program for FY 2020-2023
- FDOT Transportation Improvement Program (TIP) Modification Letter
- Quarterly Air Quality Report
- 2019 FL-AL TPO Schedule

K. OTHER BUSINESS- The next Florida-Alabama TPO meeting will be **Wednesday, June 12, 2019 at 9:00 a.m.** at the West Florida Regional Library, 239 North Spring Street, Pensacola, Florida. **Advisory committee meetings** are to be held at Pensacola City Hall, 222 West Main Street, Pensacola, Florida 32502. TCC will meet on **Monday, June 10, 2019 at 8:30 a.m.** The CAC will meet on **Tuesday, June 11, 2019 at 3:00 p.m.**

L. ADJOURNMENT

Stay up to date with TPO events and activities on Facebook: www.facebook.com/wfrpc
Questions? Email Ms. Tiffany Bates, Transportation Program Coordinator, at Tiffany.Bates@ecrc.org

Public participation is solicited without regard to race, color, national origin, sex, age, religion, disability or family status. Reasonable accommodations for access will be made in accordance with the Americans with Disabilities Act and for languages other than English. Please notify Ms. Brittany Ellers of requirements at 850-332-7976, ext. 220 or 1-800-955-8771 for TTY-Florida at least 48 hours in advance.

Introduzca la participación del público se solicita, sin distinción de raza, color, origen nacional, sexo, edad, religión, discapacidad o estado familiar. La OPC hará arreglos razonables para el acceso a esta reunión de acuerdo con el Americans with Disabilities Act, y para los requisitos de idioma que no sea inglés. Notifique a la Sr. Dan Deanda (dan.deanda@wfrpc.org) de los requisitos de acceso o el idioma en el 850-332-7976 ext. 227 o 1-800-955-8771 para TTY-Florida al menos 48 horas de antelación.

FLORIDA-ALABAMA TRANSPORTATION PLANNING ORGANIZATION MEETING MINUTES

WEST FLORIDA REGIONAL PLANNING COUNCIL (Designated staff)

West Florida Regional Library, 239 North Spring Street, Pensacola, FL

February 13, 2018

Members in Attendance:

Jeff Bergosh, Chair	Escambia County Commission
Sam Parker, Vice Chair	Santa Rosa County Commission
Cherry Fitch	Gulf Breeze Mayor
Heather Lindsay	Milton Mayor
Jerry Johnson	Orange Beach City Council
Charles Gruber	Baldwin County Commission
Doug Underhill	Escambia County Commission
Robert Bender	Escambia County Commission
Steven Barry	Escambia County Commission
Ann Hill	Pensacola City Council
Gerald Wingate	Pensacola City Council
Jewel Cannada-Wynn	Pensacola City Council
Jared Moore	Pensacola City Council
P. C. WU	Pensacola City Council
Dave Piech	Santa Rosa County Commission
Don Salter	Santa Rosa County Commission
Lane Lynchard	Santa Rosa County Commission

Others in Attendance

Bryant Paulk	FDOT
Christy Johnson	FDOT
Matt Ericksen	ALDOT
Helen Gibson	City of Pensacola
Cory Wilkinson	HDR
Shawn Ward	Santa Rosa County
Colby Brown	Escambia County
David Forte	Escambia County
Terri V. Malone	Escambia County
Leslie Statler	City of Pensacola
Tonya Ellis	Escambia County/ECAT
Joe Emerson	Citizen
James. L Gulley	Citizen
Barbara Mayall	Citizen
Patrick McClellan	Citizen
Charles Krupner	PKA
Ryan Novita	City of Pensacola
Jeff Snow	Milton City Council
Sherri Myers	Pensacola City Council
Cathy Kendall	FWHA
Kim Aderholdt	Navy Federal Credit Union
Drew Buchanan	City of Pensacola

Kevin Wade NPARC
Melissa Pino NPARC

West Florida Regional Planning Council Staff

Austin Mount
Mary Beth Washnock
Tiffany Bates
Annie Walthall
Brittany Ellers
Cameron Smith
Gabrielle Merritt
Gary Kramer
Kathy Saldana
Kristen Barre'
Rob Mahan
Tammy Neal

A. CALL TO ORDER / PLEDGE / INVOCATION- Chairman Jeff Bergosh
Chairman Bergosh led the prayer and pledge and called the meeting to order.

B. APPROVAL OF AGENDA
Ms. Bates stated that an incorrect scope was put into Enclosure G but that a corrected copy was provided.

Commissioner Bender moved to approve the December 2018 agenda. Councilwoman Cannada-Wynn seconded the motion and it was unanimously approved.

C. PUBLIC FORUM
Ms. Sherri Myers, Pensacola City Councilwoman, spoke regarding her concerns of the lack of attention to the safety issue and lack of lighting on 9th Avenue, specifically the northern portion. Councilwoman Myers stated that she and a few citizens made a video of themselves trying to cross 9th Avenue at Brent Lane while it was dark outside. Councilwoman Myers stated that the video shows that it was nearly impossible to see when crossing 9th Avenue due to the lack of street lighting.

Ms. Barbara Mayall, FL-AL CAC member, discussed the Escambia County Youth Committee. Ms. Mayall also discussed the new changes to the day and time of the CAC meeting. Ms. Mayall stated that having the CAC meeting on a different day than the TCC made it inconvenient for those who wanted to attend both meetings.

D. FHWA/FDOT/ALDOT PRESENTATIONS/UPDATES:
1. ENCLOSURE A- TPO ONLY: FEDERAL HIGHWAY ADMINISTRATION (FHWA):
Presentation of Certification Results by Federal Highway Administration (FHWA) and Federal Transit Administration (FTA) Ms. Cathy Kendall, AICP, FWHA Florida Division Planning Team Leader

Ms. Cathy Kendall presented and stated that there was a site visit and public meeting on August 14, 2018. Ms. Kendall stated that there was one noteworthy practice, which was the RideOn initiatives and partnership for multi-regional coordination. The one corrective action was that mandatory elements of the Public Participation Plan are not addressed in the TPO's PPP. The recommendations for outreach and public participation included an update of the TPO's website to make information more readily accessible, strategize to help the TPO demonstrate equity and nondiscrimination in project planning, and to ensure general PPP and specific public involvement plans for LRTP are consistent. There was a recommendation made to strengthen the distinct identity of the FL-AL TPO to improve MPO structure, and regular coordination with area transit providers, and an update to citations when renewing agreements.

2. ENCLOSURE B- TPO ONLY: ALABAMA DEPARTMENT OF TRANSPORTATION (ALDOT) Consideration to Authorize the Chairman to Sign an Infrastructure for Rebuilding America (INFRA) Grant Application Support Letter for I-10 Congestion Relief, Mobile River Bridge and Bayway Project- Mr. Matthew Ericksen, P.E., ALDOT Mobile River Bridge & Bayway Project Director

Mr. Matt Ericksen, ALDOT project director, gave a brief presentation on the Mobile River Bridge and Bayway. Mr. Ericksen discussed the George Wallace Tunnel traffic projections and stated that the built capacity for the tunnel was originally 35,000 in 1983 and is now an average of 75,000 daily traffic volume. The Bayway replacement would replace the existing 7-mile bridges above the 100-year storm surge level. It would have eight lanes of travel at approximately 10 feet higher than the existing.

The project would be funded by an all-electronic tolling system. The rates are still to be determined but are estimated to cost ~\$3-\$6 dollars. The toll collection is to start when the project is complete (2025). Commissioner Underhill stated that he was in going to vote in opposition to this measure and that he was not in favor of the toll.

Commissioner Gruber moved to authorize the TPO chairman to sign a letter of support for the I-10 Congestion Relief, Mobile River Bridge and Bayway Project grant application. Councilman Johnson seconded the motion. The motion passed with one opposed.

3. ALDOT UPDATE: Mr. Vincent Beebe, P.E., Alabama Department of Transportation (ALDOT)

Mr. Gary Kramer stated that Vince Beebe is in Montgomery this week and apologizes for not being able to attend the TPO and advisory committees this month. Mr. Kramer provided the briefing of 4 projects in the Orange Beach area and he will provide any follow-up information on the projects if necessary.

Utilities are currently being relocated for the SR-180 (Canal Road) Widening from Foley Beach Express to SR-161 (Orange Beach Boulevard) project. Plans for roadway construction are expected to be bid and let on April 26, 2019.

Plans are approximately 60% complete and ALDOT is working to obtain ROW for the SR-180 (Canal Road) at SR-161 (Orange Beach Boulevard) Intersection Improvement (Curve project) project. The project is expected to be let for construction in Early 2020.

Mr. Kramer reported that mainline paving has been completed for the SR-182 (Perdido Beach Boulevard) resurfacing project from Perdido Pass Bridge to AL-FL state line. ALDOT is finalizing driveway and side street tie-in paving and final roadway paint will be applied in approximately 2 weeks.

Mr. Kramer gave several updates on the new roadway and bridge from SR-180 (Canal Rd.) to Foley Beach Express (FBE) also known as the "Waterways" project. Mr. Kramer stated that ALDOT is working with the Corps of Engineers and Coast Guard to obtain environmental clearances / permits. Plan revisions are being considered based on public comments received during the public involvement meeting. The current schedule will likely allow the northern roadway portion to be let for construction before the bridge portion. Utility and right-of-way coordination are ongoing.

4. FDOT UPDATE: Mr. Bryant Paulk, AICP, or Ms. Christy Johnson, AICP, Florida Department of Transportation (FDOT) Urban Liaisons

Mr. Paulk stated that he only had one item to update the board on. Mr. Paulk stated that Mr. Kevin J. Thibault had been chosen the new Secretary of the Florida Department of Transportation. Mr. Paulk stated that Mr. Thibault has extensive experience in the private and public sectors and has previously served for many years at FDOT. Mr. Paulk added that he also has extensive experience in state government, having previously served in senior leadership positions with the Florida Department of Transportation for more than 16 years.

E. CONSENT: ALL COMMITTEES: Approval of December 2018 Meeting Minutes.

Commissioner Underhill moved to approve the 2018 December meeting minutes. Commissioner Bender seconded the motion and it passed unanimously.

F. ACTION:

- 1. ENCLOSURE C- ALL COMMITTEES Consideration of Resolution FL-AL 19-02 to Approve the Scope of Services for the Florida-Alabama TPO 2045 Long Range Transportation Plan Update- Mr. Gary Kramer, WFRPC Staff.**

Mr. Kramer presented the Scope of Services for the Florida-Alabama TPO 2045 Long Range Transportation plan update. Mr. Kramer stated that this action is recommended to begin the Long-Range Plan update as soon as possible in order meet the November 3, 2020 adoption date.

Commissioner Underhill moved to authorize the TPO chairman to sign Resolution FL-AL 19-02 to approve the scope of services for the Florida-Alabama TPO 2045 Long Range Transportation Plan update. Councilwoman Cannada-Wynn seconded the motion and it was unanimously approved.

2. **ENCLOSURE D- ALL COMMITTEES Consideration of Resolution FL-AL 19-03 Adopting the Transportation Alternatives (TA) Set-Aside Ranked Projects- Ms. Kristen Barre', WFRPC Staff.**

Ms. Barre' presented the Transportation Alternatives (TA) Set-Aside ranked projects. Ms. Barre' stated that a total of 11 applications from the Florida-Alabama TPO area were submitted by the January 4, 2019 deadline and the applications were ranked according to adopted ranking criteria. Ms. Barre' gave a brief background on the project scoring criteria and the requirements.

Commissioner Underhill stated that he was very disturbed to see that 3 projects that were not even ranked in 2018 are now the top 3 projects and that the project in his district that has long been a priority of the board, Perdido Key Path, moved from #2 to #8. Commissioner Underhill stated that there was discussion held in the TCC meeting regarding the scoring process and that he would like to hear from Escambia County staff member David Forte as to how the Escambia County projects came to rank so low.

David Forte, Escambia County Public Works, stated that the submission is the same as last year that the new projects submitted this year have higher scores and therefore ranked above the rest. Mr. Forte stated that the TCC discussed having a workshop that discussed the projects scoring and rankings prior to being presented and adopted. Commissioner Underhill stated that he wanted to echo the TCC's concerns about the scoring criteria.

Commissioner Underhill stated that he is very supportive of the city making it a more walkable city, but that it cannot come at the expense of the rest of the county. He stated that the city is hitting just about every funding source they possibly can right now and that they must remember that tax payers' dollars are a zero-sum game. Commissioner Underhill stated that other areas in the county who have pleaded and waited for projects to get funded cannot get bumped simply because the city has come up with new options. Commissioner Underhill stated that he would like to see this item tabled and to have a public discourse.

Councilman Wu stated that it has been a long time since the City of Pensacola received any TAP funding. Commissioner Barry asked how much money was available for these projects. Commissioner Bergosh stated that it was 3 million dollars throughout district 3.

Councilwoman Hill ask if the criteria have been the same since the it was adopted in 2015. Mr. Barre' stated that it has not changed. Councilwoman Hill asked if there were any criteria that took in consideration and gave more point to projects that had been submitted the longest. Ms. Barre' stated that there were no criteria that gave points for how many years a project is submitted. Councilwoman Hill recommended that the criteria be reevaluated. Councilwoman Hill stated that she believed it was a very fair process and that the project was ranked on very good criteria.

Councilman Wingate moved to authorize the TPO chairman to sign Resolution FL-AL 19-03 adopting the Transportation Alternatives (TA) Set-aside ranked projects. Councilwoman Hill seconded the motion. The motion passed with one opposed.

3. **ENCLOSURE E- ALL COMMITTEES Consideration of Resolution FL-AL 19-05 Approving TPO Staff to Coordinate with the City of Pensacola and Escambia County Staff to Finalize a Scope of Services and Enter into a Contract with the TPO's General Planning Consultant for the West Cervantes Street Corridor Traffic Feasibility Study- Ms. Jill Lavender, WFRPC Staff.**

Ms. Lavender stated that at the TPO's December 12, 2018 meeting, FDOT staff recommended that the county and city allow the TPO's general planning consultant to perform the study. On January 10, 2019, the Escambia County Board of County Commissioners approved a resolution supporting the FDOT's recommendation to retain the TPO's general planning consultant to perform the West Cervantes Street Corridor Traffic Feasibility Study.

Commissioner Underhill moved to authorize the TPO chairman to sign Resolution FL-AL 19-50 approving TPO staff to coordinate with the City of Pensacola and Escambia County staff to finalize a scope of services and enter into a contract with the TPO's general planning consultant for the West Cervantes Street Corridor Traffic Feasibility Study. Commissioner Bender seconded the motion and it was unanimously approved.

4. **ENCLOSURE F- ALL COMMITTEES Consideration of Resolution FL-AL 19-01 to Adopt Targets for Safety Performance Measures- Mr. Gary Kramer, WFRPC Staff**

Mr. Kramer presented and stated that this action is recommended to comply with the February 27, 2019 deadline to remain in compliance with the federal and state regulations for transportation planning. Mr. Kramer stated that the board could either move forward with the state's target or establish their own. Mr. Kramer stated that during the December TPO and advisory committee meetings, the members were advised that if there was desire to set targets for Safety which are different from FDOT and ALDOT, comments were to be emailed by December 19, 2018. Mr. Kramer stated that no e-mails were received by that deadline.

Commissioner Underhill moved to authorize the TPO chairman to sign Resolution FL-AL 19-01 to adopt targets for Safety Performance Measures. Commissioner Bender seconded the motion and it was unanimously approved.

5. **ENCLOSURE G- ALL COMMITTEES Consideration of Resolution FL-AL 19-04 to Sign Notice to Proceed for Escambia County Area Transit (ECAT) Bus Stop Assessment Plan- Mr. Rob Mahan, WFRPC Staff.**

Mr. Mahan stated that this action is recommended to comply with ADA Bus Stop accessibility requirements. Mr. Mahan explained that the FTA requires providers of fixed route service to have a plan to bring bus stops into ADA compliance and to actively implement that plan. During development of the TPO's State Fiscal Year 2019 Unified Planning Work Program (UPWP), ECAT and TPO staff discussed programming \$65,000 of the TPO's public transportation planning funds in the FY 2019 UPWP for the TPO's general planning consultant to develop a Bus Stop Assessment Plan that would evaluate the ADA compliance of all ECAT stops and create a plan to bring non-compliant stops into compliance.

Mr. Mahan stated that the TPO's general planning consultant developed a scope of services for this project and TPO staff developed a Notice to Proceed, the Task Work Order, and UPWP task budget showing the \$65,000 budgeted for consulting services.

Commissioner Underhill moved to authorize the TPO Chairman to sign a Notice to Proceed for the TPO's general planning consultant, HDR to develop a Bus Stop Assessment Plan according to the attached Task Work Order. Councilwoman Cannada-Wynn seconded the motion and it was unanimously approved.

G. WEST FLORIDA REGIONAL PLANNING COUNCIL EXECUTIVE DIRECTOR'S REPORT- TPO ONLY- Mr. Austin Mount, WFRPC Executive Director.

Mr. Mount discussed two items with the board. Mr. Mount stated that there was a request from Walton and Washington counties to look at trying to expand a corridor feasibility study for the Old Spanish Trail. Mr. Mount stated that the eastern part of the region and beyond has already conducted several feasibility studies looking at the development of that trail. Those counties have pursued the Department of Economic Opportunity (DEO) Technical Assistance fund to be able to conduct those studies. Mr. Mount stated that he will be reaching out to Okaloosa, Santa Rosa, and Escambia counties to see if there is any interest in pursuing the grant funding through DEO to be able to conduct a study.

Mr. Mount reminded the board about the Emerald Coast Transportation Symposium that will be held on February 25th and 26th at the Springhill Suites in Navarre Florida.

H. MULTI MODAL UPDATE

There was no update.

I. PRESENTATIONS (no action):

- 1. ENCLOSURE H- ALL COMMITTEES Review of Draft Fiscal Year (FY) 2020 Unified Planning Work Program (UPWP) (Year 2)- Ms. Mary Beth Washnock, WFRPC Transportation Planning Manager.**

Ms. Washnock stated that the Florida-Alabama TPO UPWP defines the tasks, activities, responsible parties, and anticipated budget for planning activities to be undertaken in the MPA served by the TPO for FY 2019 (July 1, 2018-June 30, 2019) and FY 2020 (July 1, 2019-June 30, 2020.) TPO members, advisory committee members, staff, and the public are encouraged to review the new two-year UPWP for any potential updates and revisions. Ms. Washnock informed the board that **comments are due by March 15, 2019**. Ms. Washnock stated that the link to the DRAFT UPWP was sent out separately in an email.

- 2. ENCLOSURE I- TPO ONLY Citizens' Advisory Committee (CAC) Appointment Process- Ms. Brittany Ellers, WFRPC Staff.**

Ms. Ellers presented the CAC appointment process. Ms. Ellers stated that at the June 14, 2017 TPO meeting, the board requested staff review and refine the CAC recruitment process to attempt to engage a wider demographic in the transportation planning process. At the April 9, 2018 CAC meeting, the committee created a subcommittee responsible for determining a

recruitment process for citizens who accurately represent the demographics of the Florida-Alabama TPO study area. This subcommittee met in June and November to discuss the recruitment process. Ms. Ellers stated that as a direct result of the CAC subcommittee, the CAC appointment process was adopted as part of the CAC bylaws by both the CAC and TPO in December 2018. This process empowers TPO board members to appoint engaged citizens to the CAC from their respective jurisdictions to ensure that the geography and census-based demographics of the study area are represented.

J. INFORMATION ITEMS (no presentation necessary)

1. ENCLOSURE J- ALL COMMITTEES

- TCC and CAC December Meeting Minutes
- FL-AL TPO December Actions Report
- FDOT Changes to the Tentative Work Program for FY 2020-2024
- FDOT Transportation Improvement Program (TIP) Modification Letters
- Note of Appreciation from Britney Moore, Florida Greenways and Trails
- 2019 FL-AL TPO Schedule

K. OTHER BUSINESS- - The next Florida-Alabama TPO meeting will be Wednesday, April 10, 2019 at 9:00 a.m. at the Tiger Point Community Center, Gulf Breeze, Florida. Advisory committee meetings are to be held at Pensacola City Hall, 222 West Main Street, Pensacola, Florida 32502. TCC will meet on Monday, April 8, 2019 at 8:30 a.m. The CAC will meet on Tuesday, April 9, 2019 at 3:00 p.m.

L. ADJOURNMENT

The meeting was adjourned at 10:45 P.M.

ENCLOSURE A

ENCLOSURE A ALL COMMITTEES

SUBJECT: Request to Proceed with Amending the Florida-Alabama 2040 Long Range Transportation Plan for Two Projects: (1) I-10 from Avalon Boulevard to Okaloosa County Line and (2) I-10 at Beulah Road Interchange

ORIGIN OF SUBJECT: Florida Department of Transportation

LOCAL GOVERNMENT ACTION NEEDED: None

BACKGROUND: Since the 2040 Florida-Alabama TPO's Long Range Transportation Plan was adopted on November 3, 2015, three amendments have occurred. The first amendment pertained to two projects (1) SR 180 from SR 59 to the Foley Beach Express in Gulf Shores and Orange Beach and (2) Gregory Street/Bayfront Parkway/17th Avenue Interchange in Pensacola. The first 2040 Long Range Transportation Plan amendment was approved by the TPO on April 12, 2017. The second amendment was for an outcome of a feasibility study for West Cervantes Street from Green Street to "A" Street regarding possible lane reductions and interim improvements. This amendment was approved by the TPO on December 13, 2017. The third amendment included four projects: (1) Gulf Intracoastal Waterway Bridge from SR 180 (Canal Road) to Foley Beach Express; (2) Wolf Bay Bridge and connecting roads from SR 180 (Canal Road) to CR 20; (3) I-10 from US 29 to the Alabama state line; and (4) Nine Mile Road Corridor improvements from the vicinity of Beulah Road to East of I-10. The third amendment was approved over two consecutive meetings because two projects were tabled at the first meeting. These meetings were held April 11, 2018 and June 13, 2018. Today's amendment request is for two projects: (1) I-10 from Avalon Boulevard to Okaloosa County line and (2) I-10 at Beulah Road.

Public Participation Process Plan requirements for Long Range Transportation Plan Amendments (Adopted April 13, 2016)

Administrative modifications to the Long Range Transportation Plan are minor revisions and do not require public review but must be included in the advertisement of the TPO meeting when the modification is presented.

An amendment is a major revision to a Long Range Transportation Plan and includes adding or deleting projects to the plan. It also includes major changes to project costs, initiation dates or design concepts. Amendments must be included in the advertisement of the TPO meeting when the draft amendment is presented. The public must be provided with an opportunity to comment during public forum when the draft is presented for adoption to the TPO and advisory committees as follows:

- Provide the public with a sufficient opportunity to review the draft amended document online
- Include adoption in the advertisement of the TPO meeting when the amendment is to be presented
- Provide the public with an opportunity to comment during public forum when the amendment is presented for adoption to the TPO and advisory committees
- Publish adopted amended final document on web site

I-10 from Avalon Boulevard to Okaloosa County line (See attached map for location)

Six laning I-10 from Avalon Boulevard to Okaloosa County line is currently not in the 2040 Long Range Transportation Plan Needs and Cost Feasible Plans. The amendment adds the projects to the Needs Plan and funds the PD&E in FY 2015-2020, Design in FY 2026-2030, Right-of-Way in FY 2031-2040, and Construction in FY 2031-2040 with SIS funds and is funded in the FDOT's SIS Cost Feasible Plan. This amendment has been requested by FDOT.

<u>PD&E</u>	<u>Design</u>	<u>Right of Way</u>	<u>Construction</u>
\$3,080,000	\$21,913,000	\$0	\$233,241,000

I-10 at Beulah Road Interchange (See attached map for location)

I-10 at Beulah Road Interchange is currently in the 2040 Long Range Transportation Plan Needs Plan and partially funded in the Cost Feasible Plan. This project updates the Needs Plan and moves design from FY 2015-2020 from FY 2021-2025, right-of-way in FY 2026-2030, and construction in FY 2031-2040 with SIS funds and is funded in FDOT's SIS Cost Feasible Plan. This amendment has been requested by FDOT.

<u>PD&E</u>	<u>Design</u>	<u>Right of Way</u>	<u>Construction</u>
\$496,556	\$2,500,000	\$9,500,000	\$154,949,637

Proposed Schedule

- April 10, 2019- Authorization by the TPO to proceed with amending the 2040 Long Range Transportation Plan
- April/May 2019- Post proposed 2040 Long Range Transportation Plan amendment on-line
- May 2019 Two- public workshops (one in Escambia County and one in Santa Rosa County)
- June 12, 2019- TPO approval of the 2040 Long Range Transportation Plan amendment

Attached are the following:



- Location maps for the proposed amendment

RECOMMENDED ACTION: Approval of a motion to authorize the Florida-Alabama TPO staff to proceed with the process to amend the 2040 Long Range Transportation Plan Needs and Cost Feasible plans for 2 projects: (1) I-10 from Avalon Boulevard to Okaloosa County line and (2) I-10 at Beulah Road Interchange. Please contact Mr. Gary Kramer, ECRC staff, at (800) 226-8914, Ext. 219 or gary.kramer@ecrc.org if additional information is needed.

I-10 from Avalon Boulevard to Okaloosa County Line

Florida-Alabama TPO 2040 Long Range Transportation Plan Amendment



-  I-10 from Avalon Boulevard to Okaloosa County Line (6 Lanes)
-  TPO Boundary



I-10 at Beulah Road Interchange

Florida-Alabama TPO 2040 Long Range Transportation Plan Amendment

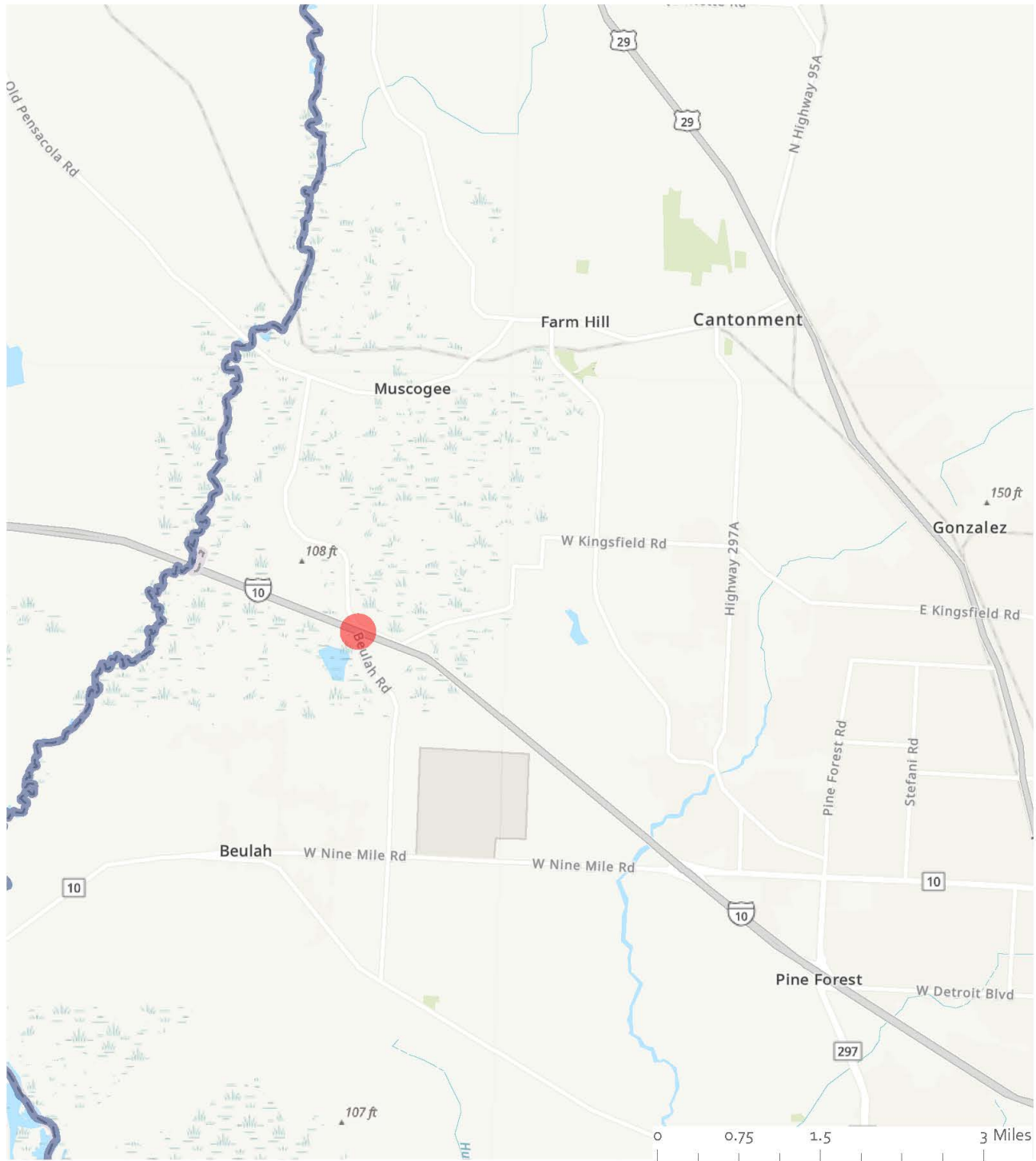

- I-10 at Beulah Road Interchange
- TPO Boundary



ENCLOSURE B

ENCLOSURE B TPO AND TCC ONLY

SUBJECT: Approval to Issue a Request for Qualifications for General Traffic Engineering Operation and Management Services and Establishing a Selection Review Committee

ORIGIN OF SUBJECT: TPO Unified Planning Work Program (UPWP) Task C.3: ITS Planning

LOCAL GOVERNMENT ACTION NEEDED: None

BACKGROUND: On September 8, 2010, through Resolution FL-AL 10-37, the Florida-Alabama TPO approved the Regional ITS Plan which includes the Florida-Alabama TPO, Okaloosa-Walton TPO, and Bay County TPO regions. An ITS Technical Working Group was created to oversee the ITS implementation efforts in the Escambia and Santa Rosa Counties. The Escambia-Santa Rosa ITS Working Group meets monthly and is made up of representatives from Escambia and Santa Rosa Counties, the City of Milton, the City of Gulf Breeze, the City of Pensacola, West Florida Regional Council, and the FDOT. The group works together to ensure the ITS system is comprehensive and includes a funding plan for the implementation and operation of a regional Advance Traffic Management System (ATMS) and a regional Traffic Management Center (TMC) and related infrastructure.

In 2015, Escambia County entered into a continuing professional services contract with DRMP, Inc. to provide general traffic engineering operation and management services including signal retiming, transportation engineering, planning and other support services for Escambia and Santa Rosa Counties. In general, the consultant is functioning as an extension of staff for traffic engineering related services funded by FDOT and TPO box funds.

On September 12, 2018 the TPO approved Resolution FL-AL 18-31 stating that the TPO agrees to be the lead agency in the development of a Regional Traffic Management Center (RTMC) and Regional ATMS build out for the on-system roadways within the TPO area and agreeing to obligate 90% of the Federal Urbanized (SU) funds in Fiscal Year 2023-2024 towards the development of the RTMC and on-system Regional ATMS improvements. The resolution also stated that the TPO intends to obligate an additional 90% of allocated Federal Urbanized (SU) funds in Fiscal Year 2024-2025 towards the development of the TMC and on-system ATMS improvements and that it intends to utilize additional signal maintenance funding and TPO Federal Urbanized (SU) funds for operations and maintenance of the built, on-system Regional ATMS for subsequent years thereafter. The resolution affirms that the TPO will continue to work with local governments to encourage the development and tie-in of local off-system ATMS improvements and expansion of the system. The TPO took this action in order to send a unified voice of support for this regional project.

In an effort to be the lead agency and to include all of the TPO area, TPO staff is recommending publishing a Request for Qualifications (RFQ) for a new professional services contract to exist between the FL-AL TPO and a firm to provide general traffic engineering operation and management services for the entire Florida-Alabama TPO area, and redirect the box funds through the TPO to support the contract. Staff is also requesting that a selection committee be established to review and rank all proposals. An email will be sent with the RFQ and details for submissions.

RECOMMENDED ACTION: Approval to issue the Request for Qualifications and establish a selection committee. This action is recommended to issue the Request of Proposals so the TPO will be the lead agency in the continuing efforts for the full build out of the Regional Advanced Traffic Management System/Regional Traffic Management Center. The TPO board will approve the final selection in June. Please contact Ms. Jill Lavender, ECRC staff, at jill.lavender@ecrc.org or 850 332-7976, Extension 212, if additional information is needed.

ENCLOSURE C

ENCLOSURE C ALL COMMITTEES

SUBJECT: Consideration of Resolution FL-AL 19-06 Adopting the FY 2019-FY 2020 Unified Planning Work Program (UPWP) Year 2 (FY 2020) Amendments, Authorizing the TPO Chairman to Sign the Certifications and Assurances and Authorizing TPO Staff to Apply for and Execute a Federal Transit Administration FTA Section 5305 Grant for Use

ORIGIN OF SUBJECT: Title 23, Code of Federal Regulations, Section 450.308; Florida Statutes Chapter 339.175 (9) (a) (2); Florida-Alabama Transportation Planning Organization (TPO) Unified Planning Work Program (UPWP)

LOCAL GOVERNMENT ACTION NEEDED: None

BACKGROUND: The UPWP is a required product of the TPO. It describes the planning work tasks and budget for the TPO fiscal year (July through June). As defined in the Code of Federal Regulations, the UPWP is a statement of work identifying the planning priorities and activities to be carried out within a metropolitan planning area. At a minimum, a UPWP includes a description of the planning work and resulting products, who will perform the work, and the source(s) of funds (23 C.F.R. 450.104). The TPO adopts a new UPWP every other year.

TPO work elements include, but are not limited to:

- TPO Administration
- Travel
- Transportation Information Management
- TIP/Project Priorities
- Long Range Transportation Planning
- Transportation Systems
- Multi-modal Planning (Public Transportation/Transportation Disadvantaged/Pedestrian and Bicycle)
- Education, Training, Outreach and Public Engagement
- Multi-state Coordination
- Corridor Management
- Transportation Project Development/Technical Assistance
- Regional and Rural Transportation Planning

The FY 2019-FY 2020 UPWP was adopted by the TPO on April 11th, 2018. As identified in the MPO Handbook, the deadline for the MPO to adopt Final Year 2 (FY 2020) is May 15, 2019. FDOT and ALDOT shall submit the final UPWP, with an approval memorandum, to the Federal Highway Administration (FHWA) and Federal Transit Administration (FTA) by June 1, 2019. After reviewing the FY 2020 tasks, amendments are proposed.

Comments on FY 2020 work tasks and budget were requested by March 15, 2019. Comments received and responses are attached and included in the draft document. TPO staff met with FDOT on March 11, 2019 and Escambia County Area Transit (ECAT) officials on March 18, 2019 to discuss their respective comments.

The draft amended FY 2019 – FY 2020 UPWP for Year 2 (2020) is accessible via the hyperlink below.

[DRAFT-Florida-Alabama-TPO-FY-2019-FY-2020-UPWP YR2](#)

Attached are the following:

- Resolution FL-AL 19-06
- Comments Received
- FTA Certifications and Assurances

RECOMMENDED ACTION: Approval of a motion to authorize the chairman to sign Resolution FL-AL 19-06 adopting the FY 2019-FY 2020 Year 2 (FY 2020) amendments, sign the FTA Certifications and Assurances and authorize TPO staff to apply for and execute an FTA Section 5305 Public Transportation Planning Grant. This action is recommended because the UPWP is a required TPO document and contains the work tasks and budget for the next fiscal year. Please contact Ms. Mary Beth Washnock, ECRC Transportation Planning Manager, at marybeth.washnock@ecrc.org or (850) 332-7976, x229 if additional information is needed.

RESOLUTION FL-AL 19-06

A RESOLUTION OF THE FLORIDA-ALABAMA TRANSPORTATION PLANNING ORGANIZATION ADOPTING THE FY2019-FY2020 UNIFIED PLANNING WORK PROGRAM (UPWP) YEAR 2 (FY 2020) AMENDMENTS

WHEREAS, the Florida-Alabama Transportation Planning Organization (TPO) is the organization designated by the governors of Florida and Alabama as being responsible, together with the states of Florida and Alabama, for carrying out the provisions 23 U.S.C. 134, as amended by the FAST Act; and

WHEREAS, the UPWP shall be adopted by the TPO and submitted to the governors of the states of Florida and Alabama and to the Federal Transit and Federal Highway Administrations, as provided in Title 23 CFR Section 450; Florida Statutes; and

WHEREAS, the FY2019-FY2020 UPWP was adopted on April 11, 2018; and

WHEREAS, the FY2019-FY2020 UPWP was reviewed by the Federal Highway Administration (FHWA), The Federal Transit Administration (FTA), the Florida and the Alabama Department of Transportation (FDOT and ALDOT), and

WHEREAS, the FY2020 work tasks and corresponding budgets have been reviewed and comments submitted by the March 15, 2019 deadline; and

WHEREAS, all comments received have been addressed and incorporated into the draft document where appropriate;

NOW, THEREFORE, BE IT RESOLVED BY THE FLORIDA-ALABAMA TRANSPORTATION PLANNING ORGANIZATION THAT:

- 1) The FY2019-FY2020 UPWP Year 2 (FY2020) amendments are hereby adopted.
- 2) The TPO chairman is authorized to sign the FTA Certifications and Assurances.
- 3) TPO staff is authorized to apply for and execute an FTA Section 5305 Public Transportation Planning grant.

Passed and duly adopted by the Florida-Alabama TPO this 10th day of April 2019.

**FLORIDA-ALABAMA TRANSPORTATION
PLANNING ORGANIZATION**

BY: _____
Jeff Bergosh, Chairman

ATTEST: _____

Draft FL-AL TPO UPWP FY2020

FDOT Comments

3/4/2019

- Task A.1 Administration: There is a significant reduction in funding for this task from year one to year two. The Department wants to ensure the proposed funding level allows the TPO to complete all the items identified in the task.
Staff programmed a significant amount of funds into year one based on the assumption that PL funds needed to be spent in order to acquire SU funds. There will be a reasonable amount of carry forward from year one to year two.
- Task C.5 Outreach & Public Engagement: There is a significant reduction in funding for this task from year one to year two. This may be due to not scheduling a Symposium for FY20, the Department wants to ensure the proposed funding level allows the TPO to complete all the items identified in the task.
Task C.5 was similarly programmed with PL funds in year one. There should be a reasonable amount of carry forward from year one to year two.
- Statements & Assurances: Please ensure to included updated versions of the documents in the final UPWP.
Updated Statements & Assurances will be provided at the TPO meeting for the Chairman's signature.
- FTA 5305 Application: Please ensure to include the most recent 5305 Application in the final UPWP.
The FTA 5305 Application will be provided at the TPO meeting for the Chairman's signature.



Escambia County Area Transit Comments on the Draft Florida -Alabama TPO FY 2020 UPWP

Staff Responses are Shaded.

There are a few items within the C.4 tasks we are requesting clarification and possible modification. Please see the comments below.

- Page 5
 - Add performance targets to “Development of Transit Asset Management (TAM) Plan

This has been added.

- Page 6
 - Add C.4 in the “The Florida-Alabama TPO will address the performance measurements in Tasks C.1, C.2, C.3, and C.6.” The MPO is required to set transit asset management performance targets for each performance measure, per 23 CFR § 306.45. MPOs are also required to reference the performance targets and performance-based plans into their TIPs and Metropolitan Transportation Plans by October 2018, per 23 CFR § 450.324 and 23 CFR § 450.326.

Task C.4 has been added.

- Page 7
 - FL-AL TPO included these in the FY 2018 UPWP, but not the current UPWP.
 - “Federal Planning Factors: The FAST Act federal transportation regulations and guidelines outline planning emphasis areas as (1) FAST Act Implementation, (2) Regional Models of Cooperation, and (3) Ladders of Opportunity.”

The Federal Planning Factors and FDOT Planning Emphasis Areas are up to date.

- Page 8
 - The Intergovernmental Coordination and Review (ICAR) and Public Transportation Coordination Joint Participation Agreement (JPA) was updated and executed on June 9, 2010 and was reaffirmed on April 8, 2015. *The ICAR is due to be updated or re-affirmed in 2020, which needs to be reflected in the UPWP.*

The ICAR will be updated or re-affirmed in 2020. This has been added and reflected in the UPWP.

The comments for pages 30-31 are highlighted in red below:

C.4 Multi-modal Planning

Purpose:

This task includes planning *activities that address the long-term and short-term needs for all non-single occupancy travel modes in the urbanized area*: public transportation, transportation disadvantaged and pedestrian/bicycle

Escambia County Area Transit

1515 West Fairfield Drive • Pensacola, Florida 32501 • 850.595-3228 • FAX 850.595-3222



ESCAMBIA COUNTY AREA TRANSIT

planning. Staff time spent at trainings, workshops and conferences regarding this task can be charged to this task. FTA Carryforward funds for FY 2017 equal \$164,000 and \$178,616 for FY 2018. *Are these rollover funds from the previous JPA? Can these be used to fund transit planning activities in the upcoming UPWP? During that period, the transit agency will begin the next major update to the Transit Development Plan (TDP) is due to FDOT September 2021.*

The additional words have been included in the Purpose statement and the word “planning” has been removed. The rollover funds from the previous JPA have been programmed. The General Planning Consultant for the TPO may be used for the TDP, which will save time and procurement costs to ECAT.

Previous Work Completed:

Public Transportation:

- Orange Beach Transit Feasibility Study *completed Spring 2016* **This has been removed.**
- Quarterly reports
- Grant payment to subrecipients *which subrecipients?* **ECAT. This has been added.**
- Migration of grant data and reporting from TEAM to Trams *TraMS was deployed in 2016* **This has been removed.**
- Co-management of major update of Transportation Disadvantaged Plan (TDP) *previous TDP 2016*
- Participation in Gulf Coast Rail Working Group *2016* **This has been removed.**
- Disadvantaged Business Enterprise (DBE) reporting *is this for FTA 5305 grant?* **Clarified and updated.**

The following will be included in “previous work completed”:

- **DBE reporting for FTA Section 5305, 5316 & 5317**
- **FY 20 – 24 Public Transportation Project Priorities**
- **Federal Financial Reports and Milestone Progress Reports for JARC & New Freedom**
- **TPO Transit Asset Management Performance Measures & Targets**
- **Bus Stop Accessibility Plan for ECAT**
- **Executed grant for FY 2019 FTA Section 5305 Metropolitan Planning funds**
- **Assisted ECAT staff with the FDOT & the FTA Triennial reviews**
- **Provided FTA with evidence that JARC grant is active**



Transportation Disadvantaged:

- Santa Rosa County Transportation Disadvantaged Coordinating Board satisfied all state required duties and tasks
- Escambia County Transportation Disadvantaged Coordinating Board satisfied all state required duties and tasks
- Minor update to Santa Rosa County Transportation Disadvantaged Service Plan approved May 2017 **2018 This has been updated.**
- Minor update to Escambia County Transportation Disadvantaged Service Plan approved May 2017 **2018 This has been updated.**

Required Activities:

Public Transportation: *(no specific reference to coordination with Baldwin County/Orange Beach in task)*

This has been added below*

- Technical assistance and staff support for public transportation in the Pensacola, FL-AL UZA
- Project administration and oversight implementation for remaining JARC and New Freedom funds
- Assist ECAT in development of performance measures *system performance measures or specifically TAM performance measures?*

TAM performance measures. This has been added.

- Establish routine coordination with ECAT, **BRATS and Orange Beach ***
- Working with transit and local governments to prepare for ACES vehicle impacts
- Travel to trainings, workshops, conferences
- Presentations at meetings and workshops
- *Transit Development Plan (TDP) Major Update - Coordinate contract, along with Escambia, Santa Rosa and Baldwin Counties & ECAT staff, to make sure the completed project fulfills the scope of services and FDOT requirements. The previous TDP Process to begin in March 2015 and to be completed by September 2016.*

The General Planning Consultant for the TPO may be used for the TDP, which will save time and procurement costs to ECAT.

- *Update the Intergovernmental Coordination and Review (ICAR) and Public Transportation Coordination Joint Participation Agreement (JPA)*

This will be updated or re-affirmed.

- *Coordinate with ECAT and ~~BRATS~~ on meeting TPO TAM performance targets*
Removed "BRATS"
- *GIS/Census – Integrate updated service area population data, route information, bus stops, etc. into internal GIS system, ~~including~~ that feeds into GTFS data*
- *Manage the Bus Stop Assessment Plan for ECAT performed by the FL-AL TPO GPC*



ESCAMBIA COUNTY AREA TRANSIT

These changes have been made.

Transportation Disadvantaged: *(not specifying that task include both Escambia and Santa Rosa Counties)*

Further clarification that the program is for both counties has been made.

For Santa Rosa County and Escambia County

- Attend trainings
- Complete Actual Expenditures Report (AER)
- Review Annual Operating Report (AOR)
- Approve evaluation
- Hold public hearings
- Update bylaws for approval
- Grievance procedures for approval
- *Jointly develop and annually update the Transportation Disadvantaged Service Plan (TDSP) with the community transportation coordinator and the local coordinating board*

This has been added.

Staff Comments Received on FL-AL TPO FY 2020 UPWP:

Task A.1

Required Activities:

Added "Procurement of Legal Services"

End Product:

Added "2nd Year Update of FY 2019-FY 2020 UPWP, Spring 2019"

Added "Legal Services Procured, Summer 2019"

Task C.4

Required Activities:

Added "Transportation Alternatives Workshops"

End Product:

Added "Transportation Alternatives Workshops Held, As Scheduled"

Estimated Budget Detail for FY 2020

Funds were moved for consultant assistance with the Transportation Alternatives Process.

Task D.1

End Product:

Added "East Bay Blvd. Corridor Management Plan, Spring 2020"

FLORIDA DEPARTMENT OF TRANSPORTATION
UNIFIED PLANNING WORK PROGRAM (UPWP)
STATEMENTS AND ASSURANCES

525-010-08
POLICY PLANNING
02/18

DEBARMENT and SUSPENSION CERTIFICATION

As required by the USDOT regulation on Governmentwide Debarment and Suspension at 49 CFR 29.510

(1) The Florida-Alabama TPO hereby certifies to the best of its knowledge and belief, that it and its principals:

- (a) Are not presently debarred, suspended, proposed for debarment, declared ineligible, or voluntarily excluded from covered transactions by any federal department or agency;
- (b) Have not, within a three-year period preceding this proposal, been convicted of or had a civil judgment rendered against them for commission of fraud or a criminal offense in connection with obtaining, attempting to obtain, or performing a public (federal, state or local) transaction or contract under a public transaction, violation of federal or state antitrust statutes; or commission of embezzlement, theft, forgery, bribery, falsification or destruction of records, making false statements, or receiving stolen property;
- (c) Are not presently indicted for or otherwise criminally or civilly charged by a governmental entity (federal, state or local) with commission of any of the offenses listed in paragraph (b) of this certification; and
- (d) Have not, within a three-year period preceding this certification, had one or more public transactions (federal, state or local) terminated for cause or default.

(2) The Florida-Alabama TPO also hereby certifies that if, later, it becomes aware of any information contradicting the statements of paragraphs (a) through (d) above, it will promptly provide that information to the U.S.D.O.T.

Name:

Title: TPO Chairman

April 10, 2019_____

Date

FLORIDA DEPARTMENT OF TRANSPORTATION
UNIFIED PLANNING WORK PROGRAM (UPWP)
STATEMENTS AND ASSURANCES

525-010-08
POLICY PLANNING
02/18

LOBBYING CERTIFICATION for GRANTS, LOANS and COOPERATIVE AGREEMENTS

In accordance with Section 1352 of Title 31, United States Code, it is the policy of the Florida-Alabama TPO that:

- (1) No Federal or state appropriated funds have been paid or will be paid by or on behalf of the Florida-Alabama TPO, to any person for influencing or attempting to influence an officer or employee of any Federal or state agency, or a member of Congress or the state legislature in connection with the awarding of any Federal or state contract, the making of any Federal or state grant, the making of any Federal or state loan, extension, continuation, renewal, amendment, or modification of any Federal or state contract, grant, loan, or cooperative agreement.
- (2) If any funds other than Federal appropriated funds have been paid or will be paid to any person for influencing or attempting to influence an officer or employee of any Federal agency, a Member of Congress, an officer or employee of Congress, or an employee of a Member of Congress in connection with this Federal contract, grant, loan or cooperative agreement, the undersigned shall complete and submit Standard Form-LLL, "Disclosure Form to Report Lobbying," in accordance with its instructions.
- (3) The Florida-Alabama TPO shall require that the language of this certification be included in the award documents for all subawards at all tiers (including subgrants and contracts and subcontracts under grants, subgrants, loans, and cooperative agreement), which exceeds \$100,000, and that all such subrecipients shall certify and disclose accordingly.
- (4) This certification is a material representation of fact upon which reliance was placed when this transaction was made or entered into. Submission of this certification is a prerequisite for making or entering into this transaction imposed by Section 1352, Title 31, U.S. Code. Any person who fails to file the required certification shall be subject to a civil penalty of not less than \$10,000 and not more than \$100,000 for each failure.

Name: Jeff Bergosh
Title: TPO Chairman

April 10, 2019
Date

FLORIDA DEPARTMENT OF TRANSPORTATION
UNIFIED PLANNING WORK PROGRAM (UPWP)
STATEMENTS AND ASSURANCES

525-010-08
POLICY PLANNING
02/18

DISADVANTAGED BUSINESS ENTERPRISE UTILIZATION

It is the policy of the Florida-Alabama TPO that disadvantaged businesses, as defined by 49 Code of Federal Regulations, Part 26, shall have an opportunity to participate in the performance of MPO contracts in a nondiscriminatory environment. The objectives of the Disadvantaged Business Enterprise Program are to ensure non-discrimination in the award and administration of contracts, ensure firms fully meet eligibility standards, help remove barriers to participation, create a level playing field, assist in development of a firm so it can compete successfully outside of the program, provide flexibility, and ensure narrow tailoring of the program.

The Florida-Alabama TPO, and its consultants shall take all necessary and reasonable steps to ensure that disadvantaged businesses have an opportunity to compete for and perform the contract work of the Florida-Alabama TPO, in a non-discriminatory environment.

The Florida-Alabama TPO shall require its consultants to not discriminate on the basis of race, color, national origin and sex in the award and performance of its contracts. This policy covers in part the applicable federal regulations and the applicable statutory references contained therein for the Disadvantaged Business Enterprise Program Plan, Chapters 337 and 339, Florida Statutes, and Rule Chapter 14-78, Florida Administrative Code

Name: Jeff Bergosh
Title: TPO Chairman

April 10, 2019
Date

TITLE VI/ NONDISCRIMINATION ASSURANCE

Pursuant to Section 9 of US DOT Order 1050.2A, the Florida-Alabama TPO assures the Florida Department of Transportation (FDOT) that no person shall on the basis of race, color, national origin, sex, age, disability, family or religious status, as provided by Title VI of the Civil Rights Act of 1964, the Civil Rights Restoration Act of 1987, the Florida Civil Rights Act of 1992 and other nondiscrimination authorities be excluded from participation in, be denied the benefits of, or be otherwise subjected to discrimination or retaliation under any program or activity.

The Florida-Alabama TPO further assures FDOT that it will undertake the following with respect to its programs and activities:

1. Designate a Title VI Liaison that has a responsible position within the organization and access to the Recipient's Chief Executive Officer.
2. Issue a policy statement signed by the Chief Executive Officer, which expresses its commitment to the nondiscrimination provisions of Title VI. The policy statement shall be circulated throughout the Recipient's organization and to the general public. Such information shall be published where appropriate in languages other than English.
3. Insert the clauses of *Appendices A and E* of this agreement in every contract subject to the Acts and the Regulations
4. Develop a complaint process and attempt to resolve complaints of discrimination against sub-recipients. Complaints against the Recipient shall immediately be forwarded to the FDOT District Title VI Coordinator.
5. Participate in training offered on Title VI and other nondiscrimination requirements.
6. If reviewed by FDOT or USDOT, take affirmative action to correct any deficiencies found within a reasonable time period, not to exceed ninety (90) calendar days.
7. Have a process to collect racial and ethnic data on persons impacted by your agency's programs.

THIS ASSURANCE is given in consideration of and for the purpose of obtaining any and all federal funds, grants, loans, contracts, properties, discounts or other federal financial assistance under all programs and activities and is binding. The person whose signature appears below is authorized to sign this assurance on behalf of the Recipient.

Name: Jeff Bergosh
Title: TPO Chairman

April 10, 2019

Date

APPENDICES A and E

During the performance of this contract, the contractor, for itself, its assignees and successors in interest (hereinafter referred to as the "Contractor") agrees as follows:

- (1) **Compliance with Regulations:** The Contractor shall comply with the Regulations relative to nondiscrimination in Federally-assisted programs of the U.S. Department of Transportation (hereinafter, "USDOT") Title 49, Code of Federal Regulations, Part 21, as they may be amended from time to time, (hereinafter referred to as the Regulations), which are herein incorporated by reference and made a part of this Agreement.
- (2) **Nondiscrimination:** The Contractor, with regard to the work performed during the contract, shall not discriminate on the basis of race, color, national origin, sex, age, disability, religion or family status in the selection and retention of subcontractors, including procurements of materials and leases of equipment. The Contractor shall not participate either directly or indirectly in the discrimination prohibited by section 21.5 of the Regulations, including employment practices when the contract covers a program set forth in Appendix B of the Regulations.
- (3) **Solicitations for Subcontractors, including Procurements of Materials and Equipment:** In all solicitations made by the Contractor, either by competitive bidding or negotiation for work to be performed under a subcontract, including procurements of materials or leases of equipment; each potential subcontractor or supplier shall be notified by the Contractor of the Contractor's obligations under this contract and the Regulations relative to nondiscrimination on the basis of race, color, national origin, sex, age, disability, religion or family status.
- (4) **Information and Reports:** The Contractor shall provide all information and reports required by the Regulations or directives issued pursuant thereto, and shall permit access to its books, records, accounts, other sources of information, and its facilities as may be determined by the *Florida Department of Transportation, the Federal Highway Administration, Federal Transit Administration, Federal Aviation Administration, and/or the Federal Motor Carrier Safety Administration* to be pertinent to ascertain compliance with such Regulations, orders and instructions. Where any information required of a Contractor is in the exclusive possession of another who fails or refuses to furnish this information the Contractor shall so certify to the *Florida Department of Transportation, the Federal Highway Administration, Federal Transit Administration, Federal Aviation Administration, and/or the Federal Motor Carrier Safety Administration* as appropriate, and shall set forth what efforts it has made to obtain the information.
- (5) **Sanctions for Noncompliance:** In the event of the Contractor's noncompliance with the nondiscrimination provisions of this contract, the *Florida Department of Transportation* shall impose such contract sanctions as it or the *Federal Highway Administration, Federal Transit Administration, Federal Aviation Administration, and/or the Federal Motor Carrier Safety Administration* may determine to be appropriate, including, but not limited to:
 - a. Withholding of payments to the Contractor under the contract until the Contractor complies, and/or
 - b. Cancellation, termination or suspension of the contract, in whole or in part.

FLORIDA DEPARTMENT OF TRANSPORTATION
UNIFIED PLANNING WORK PROGRAM (UPWP)
STATEMENTS AND ASSURANCES

525-010-08
POLICY PLANNING
02/18

- (6) **Incorporation of Provisions:** The Contractor shall include the provisions of paragraphs (1) through (7) in every subcontract, including procurements of materials and leases of equipment, unless exempt by the Regulations, or directives issued pursuant thereto. The Contractor shall take such action with respect to any subcontract or procurement as the Florida Department of Transportation, the Federal Highway Administration, Federal Transit Administration, Federal Aviation Administration, and/or the Federal Motor Carrier Safety Administration may direct as a means of enforcing such provisions including sanctions for noncompliance. In the event a Contractor becomes involved in, or is threatened with, litigation with a subcontractor or supplier as a result of such direction, the Contractor may request the Florida Department of Transportation to enter into such litigation to protect the interests of the Florida Department of Transportation, and, in addition, the Contractor may request the United States to enter into such litigation to protect the interests of the United States.
- (7) **Compliance with Nondiscrimination Statutes and Authorities:** Title VI of the Civil Rights Act of 1964 (42 U.S.C. § 2000d et seq., 78 stat. 252), (prohibits discrimination on the basis of race, color, national origin); and 49 CFR Part 21; The Uniform Relocation Assistance and Real Property Acquisition Policies Act of 1970, (42 U.S.C. § 4601), (prohibits unfair treatment of persons displaced or whose property has been acquired because of Federal or Federal-aid programs and projects); Federal-Aid Highway Act of 1973, (23 U.S.C. § 324 et seq.), (prohibits discrimination on the basis of sex); Section 504 of the Rehabilitation Act of 1973, (29 U.S.C. § 794 et seq.), as amended, (prohibits discrimination on the basis of disability); and 49 CFR Part 27; The Age Discrimination Act of 1975, as amended, (42 U.S.C. § 6101 et seq.), (prohibits discrimination on the basis of age); Airport and Airway Improvement Act of 1982, (49 USC § 471, Section 47123), as amended, (prohibits discrimination based on race, creed, color, national origin, or sex); The Civil Rights Restoration Act of 1987, (PL 100-209), (Broadened the scope, coverage and applicability of Title VI of the Civil Rights Act of 1964, The Age Discrimination Act of 1975 and Section 504 of the Rehabilitation Act of 1973, by expanding the definition of the terms “programs or activities” to include all of the programs or activities of the Federal-aid recipients, sub-recipients and contractors, whether such programs or activities are Federally funded or not); Titles II and III of the Americans with Disabilities Act, which prohibit discrimination on the basis of disability in the operation of public entities, public and private transportation systems, places of public accommodation, and certain testing entities (42 U.S.C. §§ 12131 -- 12189) as implemented by Department of Transportation regulations at 49 C.F.R. parts 37 and 38; The Federal Aviation Administration’s Non-discrimination statute (49 U.S.C. § 47123) (prohibits discrimination on the basis of race, color, national origin, and sex); Executive Order 12898, Federal Actions to Address Environmental Justice in Minority Populations and Low-Income Populations, which ensures non-discrimination against minority populations by discouraging programs, policies, and activities with disproportionately high and adverse human health or environmental effects on minority and low-income populations; Executive Order 13166, Improving Access to Services for Persons with Limited English Proficiency, and resulting agency guidance, national origin discrimination includes discrimination because of limited English proficiency (LEP). To ensure compliance with Title VI, you must take reasonable steps to ensure that LEP persons have meaningful access to your programs (70 Fed. Reg. at 74087 to 74100); Title IX of the Education Amendments of 1972, as amended, which prohibits you from discriminating because of sex in education programs or activities (20 U.S.C. 1681 et seq)

ENCLOSURE D

ENCLOSURE D ALL COMMITTEES

SUBJECT: Appointment of Nominating Committee for the Election of Florida-Alabama Transportation Planning Organization (TPO) and Advisory Committee Chairman and Vice-Chairman for Fiscal Year (FY) 2020

ORIGIN OF SUBJECT: Florida-Alabama TPO Bylaws

LOCAL GOVERNMENT ACTION NEEDED: None

BACKGROUND: The Florida-Alabama TPO Bylaws Section 1.04 (5) p. 3 states:

"The TPO chair shall appoint a nominating committee at the regular TPO meeting in April (or in the event there is not a meeting in April, the appointment shall take place at the next TPO meeting). The nominating committee shall report its recommended candidates for officers at the next TPO meeting. Nominations may also be made from the floor."

The Florida-Alabama TPO Bylaws Section 1.04 (4) p. 3 states:

"Election of TPO officers shall be part of the regular TPO meeting in June (or in the event there is not a meeting in June, the election shall take place at the next TPO meeting). Newly elected officers shall assume their duties at the next meeting following the election. They shall hold office for one year, or until their successors are elected, and they shall be eligible for re-election."

Therefore, in order to elect a chairman and vice-chairman for the upcoming fiscal year, the TPO and advisory committees should appoint nominating committees at the April 2019 meetings to consist of three members and one alternate. The nominating committees will meet fifteen minutes prior to the June 12, 2019 TPO meeting and 15 minutes prior to the June 10, 2019 TCC and June 11, 2019 CAC advisory committee meetings to discuss the nominations and present their recommendation at the meetings. This will be an advertised meeting.

Attached are the following:

- Current TPO Voting Members Roster
- Current TCC Voting Members Roster
- Current CAC Voting Members Roster

RECOMMENDED ACTION: Approval of a motion appointing three members and one alternate to the nominating committee. This action is necessary to elect a chairman and vice-chairman for the upcoming fiscal year. Please contact Ms. Tiffany Bates, ECRC staff, at 850-332-7976, Extension 217 or Tiffany.Bates@ecrc.org if additional information is needed.

Florida-Alabama



Transportation Planning Organization

Florida-Alabama TPO Voting Members Roster

BALDWIN COUNTY COMMISSION

CHARLES F GRUBER COMMISSIONER
BALDWIN COUNTY BOARD OF COUNTY COMMISSION
201 E SECTION AVE
FOLEY AL 36535

Contact email: cgruber@baldwincountyal.gov
Contact Phone: (251) 943-5061 Ext: 2804
Contact FAX: (251) 972-6842

CITY OF GULF BREEZE

CHERRY FITCH MAYOR
CITY OF GULF BREEZE
P O BOX 640
GULF BREEZE FL 32561-0640

Contact email: cfitch@gulfbreezefl.gov
Contact Phone: (850) 934-5114

CITY OF MILTON

HEATHER LINDSAY MAYOR
CITY OF MILTON
PO BOX 909
MILTON FL 32572

Contact email: hlindsay@miltonfl.org

CITY OF ORANGE BEACH

JERRY JOHNSON COUNCIL MEMBER
CITY OF ORANGE BEACH
PO BOX 458
ORANGE BEACH AL 36561

Contact email: jjohnson@cityoforangebeach.com
Contact Phone: (251) 504-8910
Work Phone: (251) 981-2610

CITY OF PENSACOLA

JEWEL CANNADA-WYNN COUNCIL MEMBER
CITY OF PENSACOLA
222 WEST MAIN STREET
PENSACOLA FL 32502

Contact email: jcannada-wynn@cityofpensacola.com
Contact Phone: (850) 436-5655

ANN HILL COUNCIL MEMBER
CITY OF PENSACOLA
412 WEST GREGORY STREET
PENSACOLA FL 32501

Contact email: ahill@cityofpensacola.com
Contact Phone: (850) 418-3492

JARED MOORE COUNCIL MEMBER
CITY OF PENSACOLA
4485 MCCLELLAN ROAD
PENSACOLA FL 32503

Contact email: jmoore@cityofpensacola.com
Contact Phone: (850) 418-2269



Florida-Alabama TPO Voting Members Roster

GERALD WINGATE COUNCILMAN
CITY OF PENSACOLA
32 ESCALONA AVENUE
PENSACOLA FL 32503

Contact email: gwingate@cityofpensacola.com
Contact Phone: (850) 607-0185

P C WU COUNCILMAN
CITY OF PENSACOLA
3960 POTOSI ROAD
PENSACOLA FL 32504

Contact email: pcwu@cityofpensacola.com
Contact Phone: (850) 477-5279
Contact FAX: (850) 435-1611

ESCAMBIA COUNTY COMMISSION

STEVEN BARRY COMMISSIONER
ESCAMBIA BOARD OF COUNTY COMMISSIONERS
PO BOX 1591
PENSACOLA FL 32591 1591

Contact email: district5@myescambia.com
Contact Phone: (850) 595-4950

ROBERT BENDER COMMISSIONER
ESCAMBIA BOARD OF COUNTY COMMISSIONERS
221 PALAFOX PLACE SUITE 400
PENSACOLA FL 32502

Contact email: district4@myescambia.com
Contact Phone: (850) 595-4940
Contact FAX: (850) 595-4908

JEFF BERGOSH COMMISSIONER
ESCAMBIA COUNTY BOARD OF COUNTY
COMMISSIONERS
PO BOX 1591
PENSACOLA FL 32501

Contact email: district1@myescambia.com
Contact Phone: (850) 595-4910

LUMON MAY COMMISSIONER
ESCAMBIA BOARD OF COUNTY COMMISSIONERS
221 PALAFOX PLACE 400
PENSACOLA FL 32502

Contact email: district3@myescambia.com
Work Phone: (850) 595-4930

DOUG UNDERHILL COMMISSIONER
ESCAMBIA COUNTY BOARD OF COUNTY
COMMISSIONERS
PO BOX 1591
PENSACOLA FL 32591 1591

Contact email: district2@myescambia.com
Contact Phone: (850) 595-4920



Florida-Alabama TPO Voting Members Roster

SANTA ROSA COUNTY COMMISSION

ROBERT COLE COMMISSIONER
SANTA ROSA BOARD OF COUNTY COMMISSIONERS
6495 CAROLINE STREET STE M
MILTON FL 32570

Contact email: commcole@santarosa.fl.gov
Contact Phone: (850) 983-1877
Contact FAX: (850) 983-1856

LANE LYNCHARD COMMISSIONER
SANTA ROSA BOARD OF COUNTY COMMISSIONERS
6495 CAROLINE STREET STE M
MILTON FL 32570 4592

Contact email: comm-lynchard@santarosa.fl.gov
Contact Phone: (850) 983-1877
Contact FAX: (850) 983-1856

SAM PARKER COMMISSIONER
SANTA ROSA BOARD OF COUNTY COMMISSIONERS
6495 CAROLINE STREET STE M
MILTON FL 32570 4592

Contact email: samparker@santarosa.fl.gov
Contact Phone: (850) 983-1877
Contact FAX: (850) 983-1856

DAVE PIECH COMMISSIONER
SANTA ROSA BOARD OF COUNTY COMMISSIONERS
6685 ADMIRAL STREET
NAVARRE FL 32566

Contact email: CommPiech@santarosa.fl.gov
Contact Phone: (850) 530-0046

DON SALTER
SANTA ROSA BOARD OF COUNTY COMMISSIONERS
6495 CAROLINE STREET STE M
MILTON FL 32570 4592

Contact email: comm-salter@santarosa.fl.gov
Contact Phone: (850) 983-1877
Contact FAX: (850) 983-1856



Florida-Alabama TCC Voting Members Roster

BALDWIN COUNTY

BRATS

TAYLOR RIDER TRANSPORTATION DIRECTOR
BALDWIN COUNTY
P O BOX 907
ROBERTSDALE AL 36567

Contact email: btrider@baldwincountyal.gov
Contact Phone: (251) 972-8576
Contact FAX: (251) 972-6841

Planning Department

VINCE JACKSON PLANNING DIRECTOR
BALDWIN COUNTY
PO BOX 220
SILVERHILL AL 36576

Contact email: vjackson@baldwincountyal.gov
Contact Phone: (251) 580-1655 Ext: 7238
Contact FAX: (251) 580-1656

CITY OF GULF BREEZE

City Manager's Office

SAMANTHA ABELL Deputy City Manager
CITY OF GULF BREEZE
PO BOX 640
GULF BREEZE FL 32562 0640

Contact email: sabell@gulfbreezefl.gov
Contact Phone: (850) 203-6033

CITY OF ORANGE BEACH

Community Development Department

GRIFFIN POWELL CITY PLANNER II
CITY OF ORANGE BEACH
P O BOX 2432
ORANGE BEACH AL 36561

Contact email: gpowell@cityoforangebeach.com
Contact Phone: (251) 981-6787

CITY OF PENSACOLA

City Public Works

DERRIK OWENS DIRECTOR
CITY OF PENSACOLA
P O BOX 12910
PENSACOLA FL 32521

Contact email: dowens@cityofpensacola.com
Contact Phone: (850) 435-1645

City Traffic Engineering Office

RYAN NOVOTA ENGINEER
CITY OF PENSACOLA
P O BOX 12910
PENSACOLA FL 32521

Contact email: rnovota@cityofpensacola.com
Contact Phone: (850) 436-5533

Community Redevelopment Agency

M HELEN GIBSON
CITY OF PENSACOLA
222 W MAIN STREET
PENSACOLA FL 32502

Contact email: HGibson@cityofpensacola.com
Contact Phone: (850) 436-5650



Florida-Alabama TCC Voting Members Roster

Pensacola International Airport

ANDREA LEVITT KVECH ASSISTANT AIRPORT DIRECTOR
- FINANCE
PENSACOLA INTERNATIONAL AIRPORT
2430 AIRPORT BLVD 225
PENSACOLA FL 32504

Contact email: akvech@cityofpensacola.com
Contact Phone: (850) 436-5000
Contact FAX: (850) 436-5006

Planning Department

LESLIE STATLER PLANNER
CITY OF PENSACOLA
PO BOX 12910
PENSACOLA FL 32521

Contact email: lstatler@cityofpensacola.com
Contact Phone: (850) 435-1670
Contact FAX: (850) 595-1143

Port of Pensacola

AMY MILLER DIRECTOR
PORT OF PENSACOLA
P O BOX 889
PENSACOLA FL 32594

Contact email: amiller@portofpensacola.com
Contact Phone: (850) 436-5070
Contact FAX: (850) 436-5076

EASTERN SHORE MPO

Planning Department

SARAH C HART MPO COORDINATOR
EASTERN SHORE MPO
1100 FAIRHOPE AVENUE
FAIRHOPE AL 36532

Contact email: Shart@baldwincountyal.gov
Contact Phone: (251) 990-4643

EMERALD COAST UTILITIES AUTHORITY

MIKE HAMLIN PROJECT ENGINEER
EMERALD COAST UTILITIES AUTHORITY
P O BOX 17089
PENSACOLA FL 32522 7089

Contact email: mike.hamlin@ecua.fl.gov
Contact Phone: (850) 969-6501

ESCAMBIA COUNTY

Bureau of Development Services

HORACE JONES DIVISION MANAGER
ESCAMBIA COUNTY
3363 WEST PARK PLACE
PENSACOLA FL 32505

Contact email: hljones@co.escambia.fl.us
Contact Phone: (850) 595-3475

Community and Environmental Division

GLENN C GRIFFITH BROWNFIELDS COORDINATOR
ESCAMBIA COUNTY
221 PALAFOX PLACE OLD COUNTY COURTHOUSE, 4TH
FL. SUITE 305
PENSACOLA FL 32502

Contact email: gcgriffi@co.escambia.fl.us
Contact Phone: (850) 595-3538



Florida-Alabama TCC Voting Members Roster

County School District

STEVEN HARRELL TRANSPORTATION DIRECTOR
ESCAMBIA COUNTY SCHOOL DISTRICT
100 E TEXAR DRIVE
PENSACOLA FL 32503

Contact email: SHarell@escambia.k12.fl.us
Contact Phone: (850) 469-5488
Contact FAX: (850) 469-5661

Emergency Management Office

JOHN DOSH CHIEF
ESCAMBIA COUNTY
6575 NORTH W STREET
PENSACOLA FL 32505 -1094

Contact email: john_dosh@co.escambia.fl.us
Contact Phone: (850) 471-6400
Contact FAX: (850) 471-6455

Planning Department

TERRI MALONE Planner, AICP
ESCAMBIA COUNTY
3363 WEST PARK PLACE
PENSACOLA FL 32505

Contact email: TVMALONE@myescambia.com
Contact Phone: (850) 595-3425
Contact FAX: (850) 595-3405

ESCAMBIA COUNTY AREA TRANSIT

Marketing and Communications

TONYA ELLIS TRANSPORTATION PLANNER
ESCAMBIA COUNTY AREA TRANSIT
1515 W FAIRFIELD DRIVE
PENSACOLA FL 32501

Contact email: tellis@myescambia.com
Work Phone: (850) 595-3228 Ext: 1229

ESCAMBIA COUNTY CRA

Community Redevelopment Agency

MAX ROGERS PROGRAM MANAGER
COMMUNITY REDEVELOPMENT AGENCY
221 PALAFOX PLACE
PENSACOLA FL 32502

Contact email: mprogers@co.escambia.fl.us
Contact Phone: (850) 595-3499

PENSACOLA NAVAL AIR STATION

Community Planner

STEVE OPALENIK COMMUNITY PLANNER AND LIAISON
OFFICER
PENSACOLA NAVAL AIR STATION
150 HASE ROAD
PENSACOLA FL 32508

Contact email: stephen.j.opalenik@navy.mil
Contact Phone: (850) 452-8715

PENSACOLA STATE COLLEGE

Resources Department

TED YOUNG Director
PENSACOLA STATE COLLEGE
1000 COLLEGE BLVD
PENSACOLA FL 32504

Contact email: fyoung@pensacolastate.edu
Contact Phone: (850) 484-1779



Florida-Alabama TCC Voting Members Roster

SANTA ROSA BAY BRIDGE AUTHORITY

Chairman

MORGAN LAMB CHAIRMAN
SANTA ROSA BAY BRIDGE AUTHORITY
6025 OLD BAGDAD HIGHWAY
MILTON FL 32583

Contact email: info@garconpointbridge.com
Contact Phone: (850) 981-2718

SANTA ROSA COUNTY

County Administrator's Office

TONY GOMILLION COUNTY ADMINISTRATOR
SANTA ROSA COUNTY
6495 CAROLINE STREET STE D
MILTON FL 32570 4592

Contact email: tonyg@santarosa.fl.gov
Contact Phone: (850) 983-1855
Contact FAX: (850) 983-1856
Work Phone: (850) 983-1855
Work FAX: (850) 983-1856

County Engineering Office

CHRIS PHILLIPS PROJECT ENGINEER
SANTA ROSA COUNTY
6051 OLD BAGDAD HWY STE 300
MILTON FL 32583

Contact email: chrisp@santarosa.fl.gov
Contact Phone: (850) 981-7100
Contact FAX: (850) 983-2161

County Planning Office

SHAWN WARD TRANSPORTATION PLANNER CHAIR
SANTA ROSA COUNTY
6051 OLD BAGDAD HWY STE 202
MILTON FL 32583

Contact email: shawnw@santarosa.fl.gov
Contact Phone: (850) 981-7082
Work Phone: (850) 981-7082

County School Board

JUD CRANE DIRECTOR OF PURCHASING AND
CONTRACT NEGOTIATION
SANTA ROSA COUNTY SCHOOL DISTRICT
5544 FIREHOUSE ROAD
MILTON FL 32570

Contact email: cranej@mail.santarosa.k12.fl.us
Contact Phone: (850) 983-5130
Contact FAX: (850) 983-5105

Public Works Office

STEPHEN L FURMAN P E ASST PUBLIC WORKS
DIRECTOR
SANTA ROSA COUNTY
6075 OLD BAGDAD HWY
MILTON FL 32583

Contact email: stephenf@santarosa.fl.gov
Contact Phone: (850) 626-0191
Contact FAX: (850) 623-1331

UNIVERSITY OF WEST FLORIDA

Parking

CHIP CHISM PARKING MANAGER
UNIVERSITY OF WEST FLORIDA
11000 UNIVERSITY PKWY
PENSACOLA FL 32514

Contact email: jchism@uwf.edu
Contact Phone: (850) 473-7711

Florida-Alabama



Transportation Planning Organization

Florida-Alabama CAC Members Roster

ANNE B BENNETT
P O BOX 3571
PENSACOLA FL 32516

Contact Phone: (850) 207-6065

SANDY BOYD
6508 RAINBOW AVENUE
PENSACOLA FL 32505

Contact email: sandykboyd@aim.com
Contact Phone: (850) 512-3908

SEAN BULLINGTON
2276 CRICKET RIDGE DRIVE
CANTONMENT FL 32522

Contact email: seansurf777@gmail.com
Contact Phone: (850) 206-1504

VERNON COMPTON CHAIR
FLORIDA TRAIL ASSOCIATION
5149 SANTA ROSA STREET
MILTON FL 32570

Contact email: comptonv@bellsouth.net
Contact Phone: (850) 623-0987

BILL JEFFRIES
4688 WALKER AVENUE TH3
ORANGE BEACH AL 36561

Contact email: bigbilljeffries@gmail.com
Contact Phone: (251) 269-6009

MIKE KILMER
2818 W JACKSON STREET
PENSACOLA FL 32505

Contact email: mike@madhappy.com
Contact Phone: (201) 679-4168

KURT LARSON
4771 BAYOU BOULEVARD #200
PENSACOLA FL 32503

Contact email: kurt@fire-help.org
Contact Phone: (850) 469-9063

Florida-Alabama

Transportation Planning Organization

Florida-Alabama CAC Members Roster

STEVEN LEPCIER
2146 MUSKET DRIVE
NAVARRE FL 32566

Contact email: stvn_lepcier@yahoo.com
Contact Phone: (850) 776-8353

BARBARA MAYALL
3011 WINDERMERE DRIVE
PENSACOLA FL 32503

Contact email: bhealthy10@gmail.com
Contact Phone: (850) 433-7025

PATRICK M MCCLELLAN
17401 PERDIDO KEY DRIVE
PERDIDO KEY FL 32507

Contact email: Pat@florabama.com
Contact Phone: (850) 393-1818

TERRY MILLER
4528 BAYSIDE DRIVE
MILTON FL 32583

Contact email: terry.j.miller@edwardjones.com
Contact Phone: (813) 785-7137
Work Phone: (850) 995-3382

JIM ROBERTS
1520 LIGHTHOUSE COURT
GULF BREEZE FL 32563

Contact email: jim.roberts@ecua.fl.gov
Contact Phone: (850) 291-5531

LISA WALSH VICE CHAIR
1280 GOLDENROD ROAD
CANTONMENT FL 32533

Contact email: lisa.walsh04@gmail.com
Contact Phone: (850) 982-0712

ENCLOSURE E

ENCLOSURE E TPO ONLY

SUBJECT: Consideration of Appointing an Escambia County Member as an Alternate to the Northwest Florida Regional Transportation Planning Organization (RTPO)

ORIGIN OF SUBJECT: West Florida Regional Planning Council (WFRPC) Staff

LOCAL GOVERNMENT ACTION NEEDED: None

BACKGROUND: Article 4, Section 4.01 of the interlocal agreement for the Northwest Florida RTPO specifies the membership requirements of the Northwest Florida RTPO, which are summarized below:

VOTING MEMBERS

- The RTPO consists of sixteen (16) total voting members.
- Eight (8) members appointed by the Florida-Alabama TPO (with four (4) members each from Escambia County and Santa Rosa County).
- Eight (8) members appointed by the Okaloosa-Walton TPO (with four (4) members each from Okaloosa County and Walton County).
- Voting members shall be current TPO members, or TPO alternates.
- Voting members from each county may include county and municipal elected officials.

ALTERNATE VOTING MEMBERS

- Each TPO shall appoint an alternate for each voting member on the RTPO.
- RTPO alternates shall be TPO voting members or alternates serving the same general-purpose local government as the RTPO voting member.
- RTPO alternates are eligible to vote when the voting member is absent from meetings.

In order to update the membership roster, one Escambia County member is needed as an alternate. The eligible members are listed below:

Escambia:

Commissioner Robert Bender
Commissioner Doug Underhill

Attached is the following:

- Current RTPO Voting and Alternate Membership Roster

RECOMMENDED ACTION: Approval of a motion appointing one Escambia County member as an alternate to the Northwest Florida Regional Transportation Planning Organization. This action is recommended to maintain membership on the Northwest Florida Regional Transportation Planning Organization. Please contact Ms. Tiffany Bates, ECRC staff, at 1-800-226-8914, Extension 217 or Tiffany.Bates@ecrc.org if additional information is needed.



NORTHWEST FLORIDA REGIONAL TPO VOTING MEMBER AND ALTERNATES ROSTER

Escambia County Commission

Jeff Bergosh, Commissioner
Escambia Board of County Commissioners
PO Box 1591
Pensacola, FL 32501-1591

Contact email: district1@myescambia.com
Contact Phone: (850) 595-4910

Alternate: *Lumon May, Commissioner*

Steven Barry, Commissioner
Escambia Board of County Commissioners
221 Palafox Place Suite 400
Pensacola, FL 32502

Contact email: district5@myescambia.com
Contact Phone: (850) 595-4910

Alternate: *Vacant*

City of Pensacola

Gerald Wingate, Council member
City of Pensacola
PO Box 12910
Pensacola, FL 32521

Contact email: gwingate@cityofpensacola.com
Contact Phone: (850) 607-0185

Alternate: *PC Wu, Council member*

Andy Terhaar, Council member
City of Pensacola
P.O. Box 12910
Pensacola, FL 32521

Contact email: aterhaar@cityofpensacola.com
Contact Phone: (850) 393-6014
Work Phone: (850) 435-1606

Alternate: *PC Wu, Council member*

Santa Rosa County Commission

Lane Lynchard, Commissioner Chair
Santa Rosa Board of County Commissioners
6495 Caroline Street Suite M
Milton, FL 32570

Contact email: comm-lynchard@santarosa.fl.gov
Contact Phone: (850) 983-1877
Contact Fax: (850) 983-1856

Alternate: *Sam Parker, Commissioner*

Bob Cole, Commissioner
Santa Rosa Board of County Commissioners
6495 Caroline Street Suite M
Milton, FL 32570

Contact email: commcole@santarosa.fl.gov
Contact Phone: (850) 983-1877
Contact Fax: (850) 983-1856

Alternate: *Sam Parker, Commissioner*



NORTHWEST FLORIDA REGIONAL TPO VOTING MEMBER AND ALTERNATES ROSTER

Don Salter, Commissioner
Santa Rosa Board of County Commissioners
6495 Caroline Street Suite M
Milton, FL 32570

Contact email: comm-salter@santarosa.fl.gov
Contact Phone: (850) 983-1877
Contact Fax: (850) 983-1856

Alternate: Sam Parker, Commissioner

Dave Piech, Commissioner
Santa Rosa Board of County Commissioners
6495 Caroline Street Suite M
Milton, FL 32570

Contact email: comm-piech@santarosa.fl.gov
Contact Fax: (850) 983-1877
Contact Phone: (850) 983-1856

Alternate: None Available

Okaloosa County Commission

Nathan Boyles, Commissioner
Okaloosa County Board of Commissioners
1250 N. Eglin Parkway Suite 100
Shalimar, FL 32579

Contact email: nboyles@co.okaloosa.fl.us
Contact Phone: (850) 689-5030
Contact Fax: (850) 651-7142

Alternate: Carolyn Ketchel, Commissioner

City of Crestview

Bill Cox, Councilman
City of Crestview
198 Wilson Street N
Crestview, FL 32536

Contact email: billcox@cityofcrestview.org
Contact Phone: (850) 683-0987
Contact Fax: (850) 689-4575

Alternate: Shannon Hayes, Council member

City of Fort Walton Beach

Dick Rynearson, Mayor
City of Fort Walton Beach
107 Miracle Strip Pkwy SW
Fort Walton Beach, FL 32548-6614

Contact email: drynearson@fwb.org
Contact Phone: (850) 862-4004
Contact Fax: (850) 833-9640

Alternate: Amy Jamieson, Council member

Amy Jamieson, Council member
City of Fort Walton Beach
107 Miracle Strip Pkwy SW
Fort Walton Beach, FL 32548-6614

Contact email: ajamieson@fwb.org
Contact Phone: (850) 240-4669
Contact Fax: (850) 833-9640

Alternate: Chatham Morgan, Council member



NORTHWEST FLORIDA REGIONAL TPO VOTING MEMBER AND ALTERNATES ROSTER

Walton County Commission

William Chapman, Commissioner
Walton Board of County Commissioners
9446 Rock Hill Road
Ponce de Leon, FL 32455

Contact email: chabill@co.walton.fl.us
Contact Phone: (850) 835-4860

Alternate: Vacant

Trey Nick, Commissioner
Walton Board of County Commissioners
263 Chaffin Avenue
DeFuniak Springs, FL 32433

Contact email: nictrey@co.walton.fl.us
Contact Phone: (850) 835-4834
Contact Fax: (850) 835-0295
Work Phone: (850) 835-4834
Work Fax: (850) 835-0295

Alternate: Vacant

City of Freeport

Elizabeth Haffner, Council Member
City of Freeport, FL
P.O. Box 339
Freeport, FL 32439

Contact email: ehaffner@freeportflorida.gov
Contact Phone: (850) 737-1144

Alternate: Vacant

City of DeFuniak Springs

Henry Ennis, Council Member
City of DeFuniak Springs, FL
31 Coastal Centre Blvd.
Santa Rosa Beach, FL 32459`

Contact email: maccarpenter@defuniaksprings.net
Contact Phone: (850) 951-7087

Alternate: Janie Griffith, Council member

(Ex-Officio Non-Voting)

Florida Department of Transportation

Phillip Gainer, District Secretary
Florida Department of Transportation
1074 Highway 90
Chipley, FL 32528

Contact email: phillip.gainer@dot.state.fl.us
Contact Phone: (850) 330-1250
Contact Fax: (850) 330-1657

ENCLOSURE F

ENCLOSURE F ALL COMMITTEES

SUBJECT: Status Update on Escambia County Area Transit (ECAT) Bus Stop Assessment Plan

ORIGIN OF SUBJECT: Unified Planning Work Program (UPWP)

LOCAL GOVERNMENT ACTION NEEDED: None

BACKGROUND: At its last meeting in February, the TPO voted to issue a Notice to Proceed for its general planning consultant, HDR, Inc., to proceed with an assessment of all ECAT bus stops for compliance with the Americans with Disabilities Act, as described in the task work order. The first deliverable for the project the draft assessment checklist is complete and is attached for review.

Please provide all comments on the draft assessment checklist by **Wednesday, April 24, 2019**. Comments may be submitted to Mr. Rob Mahan at Rob.Mahan@ecrc.org or at 850-332-7976 extension, 212.

Attached is the following:

- Draft Assessment Checklist for ECAT Bus Stop Assessment Plan

RECOMMENDED ACTION: This item is for information. Please contact Mr. Rob Mahan, ECRC staff, at 850-332-7976, Extension 216 or rob.mahan@ecrc.org with comments or if additional information is needed.



ESCAMBIA COUNTY AREA TRANSIT



BUS STOP ASSESSMENT PLAN



2019

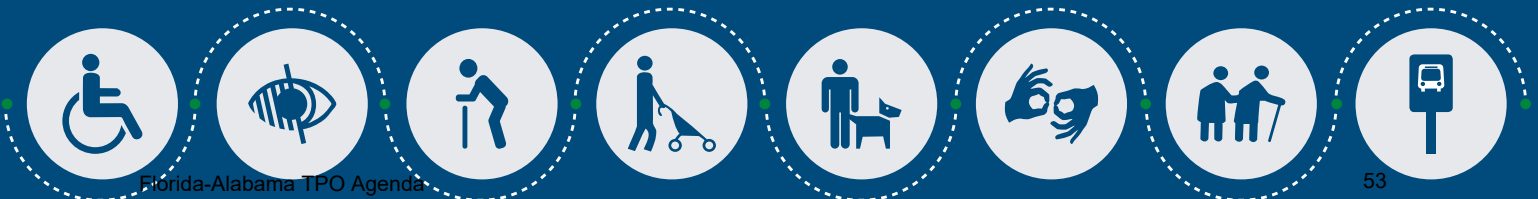



BUS STOP ADA COMPLIANCE CHECKLIST

Bus Stop ID:		Road Designation:	— US	— State	— Local
Street Name:		Functional Class:	— Local	— Arterial	— Collector
Nearest Cross Street:		Transit Route(s) No:			
Posted Speed Limit:		Other:			

1 DOES THE STOP MEET THE MINIMUM REQUIREMENTS?

Y	N	N/A

Surface Does the Boarding/Alighting area have a firm, stable surface? (supports a lift/ramp for bus entering/exiting)

Flush Shoulder If the boarding/alighting area is on a flush shoulder roadway, does it use a Type E curb (**5" curb height**) and is connected to a sidewalk along the roadway or to roadway when no sidewalk is present?

**If roadway speed is greater than 45mph, 10' of paved separation from the edge of travel to the Type E curb is required.*

**Detectable warnings are required where a sidewalk (associated with a boarding/alighting area) connects to roadway at grade.*

Dimensions Does the area meet these dimensions:

- Clear length of **8' min**, perpendicular to the curb or vehicle roadway edge; and
- Clear width of **5' min**, measured parallel to the vehicle roadway

Connections Is the Boarding/Alighting area connected to a street, sidewalk, or pedestrian path by an accessible route with a running slope of walking surfaces **not steeper than 1:20**?

Slope Is the slope of the Boarding/Alighting area **parallel to the roadway** and the same as the roadway, **not steeper than 1:48**?

Obstructions Are there any obstructions interfering with access to the boarding/alighting areas? i.e. utility pole, drainage structure, signs, driveways, other

Signage Is there a **sign mounted 7' from the floor** and contain route information? Does the design comply with:

- Sign panel is 30" tall and 18" wide
- Character height is 5/8" min and 2" max

IDENTIFY EXISTING BOARDING/ALIGHTING DIMENSIONS IN SKETCH BELOW

If applicable, shade out the missing concrete in the sketch and tabulate the costs

BUS PAD COST ESTIMATES

Sidewalk Concrete \$60.00 per SY
FL State Avg Cost 6" thick

NEW BUS PAD ESTIMATE

5' x 8' = 4.44 SY \$ 266.40

ACTUAL DIMENSIONS

Width: _____

Length: _____

Total SY: _____

Total SY Needed: _____

ESTIMATED COST: _____

MIN BUS PAD REQUIREMENTS

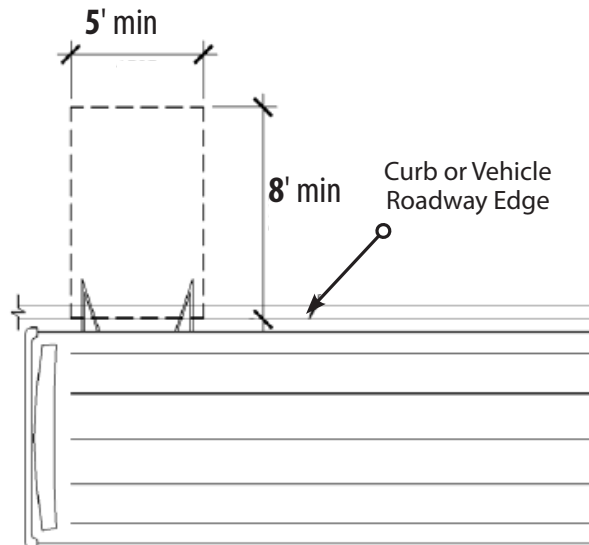

MIN BUS SIGN REQUIREMENTS

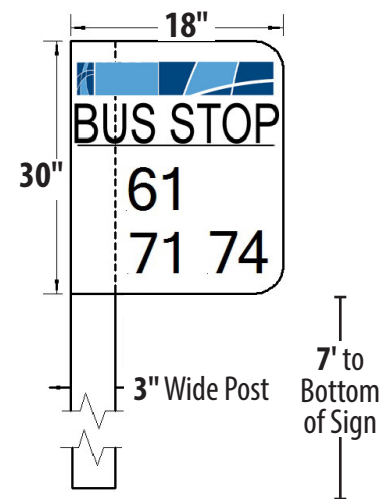

Comments:



2 STOP WITH BENCH REQUIREMENTS

Y	N	N/A

- Bench at Transit Stop with Curb** Does the bench area have a **4' clear zone** void of any obstructions from face of curb to the front of the bench?
If no, can a minor adjustment be made to make this compliant?
- Boarding/Alighting Area** Is there a **30" by 48" clear area** adjacent to the bench for wheelchair accessibility?
If no, can a minor adjustment be made to make this compliant?
- Boarding/Alighting Accessible Route** Is there an accessible route connecting the bench to the boarding/alighting area that is firm, slip resistant and at least **36" wide**?
If no, can a minor adjustment be made to make this compliant?
- Obstruction** Does the bench obstruct the **5' by 8' boarding/alighting area**?
If yes, can a minor adjustment be made to make this compliant?
- Bench Dimensions** Does the bench meet these requirements:
 — Min 20" to max 24" in seat depth
 — Max 28" in depth and 44" in height
 — Min 42", max 74" wide
 — Bench seat 17-19" above ground or floor
 — Back support extending from a point 2" max from above the seat surface to a point 18" above seat surface
If no is selected for any of this group, can a minor adjustment be made to make the bench dimensions compliant?

IDENTIFY EXISTING BOARDING/ALIGHTING DIMENSIONS IN SKETCH BELOW
If applicable, shade out the missing concrete in the sketch and tabulate the costs

BUS PAD COST ESTIMATES

Sidewalk Concrete	\$60.00 per SY
FL State Avg Cost	6" thick

NEW BUS PAD ESTIMATE

5' x 8' = 4.44 SY \$ 266.40

ACTUAL DIMENSIONS

Width: _____

Length: _____

Total SY: _____

Total SY Needed: _____

ESTIMATED COST: _____

MIN BENCH AREA REQUIREMENTS

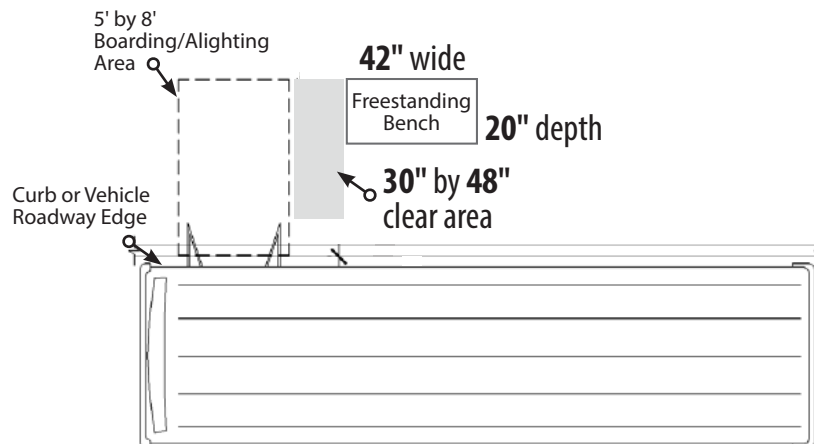

CLEAR AREA ESTIMATES

CLEAR AREA ESTIMATE

30" x 48" = 1.11 SY \$ 66.60

ACTUAL DIMENSIONS

Width: _____

Length: _____

Total SY: _____

Total SY Needed: _____

ESTIMATED COST: _____

MIN BENCH DIMENSIONS REQUIREMENTS

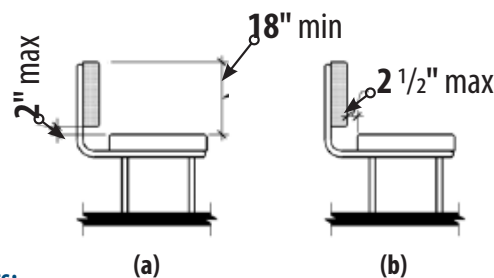

Comments:



3 STOP WITH SHELTER REQUIREMENTS

Y	N	N/A

- Boarding/Alighting Accessible Route** Is there an accessible route connecting the shelter to the boarding/alighting area that is firm, slip resistant and at least **36" wide**?
If no, can a minor adjustment be made to make this compliant?
- Clear Floor Area** Is it possible for a wheelchair to enter the shelter from the public way and reach a location having a clear floor area of **30" by 48"**, while within the perimeter of the roof of the shelter?
If no, can a minor adjustment be made to make this compliant?
- Sidewalk/Pathway Access** If shelter is on the street side of a sidewalk, is there a **min of 5'** between face of the curb and the roof or panels of the shelter.
If no, can a minor adjustment be made to make this compliant?
- Boarding/Alighting Zone** Does the shelter obstruct the **5' by 8'** boarding/alighting zone?
If yes, can a minor adjustment be made to make this compliant?
- Bench Dimensions** Does the bench meet these requirements:
 — Min 20" to max 24" in seat depth
 — Max 28" in depth and 44" in height
 — Min 42", max 74" wide
 — Bench seat 17-19" above ground or floor
 — Back support extending from a point 2" max from above the seat surface to a point 18" above seat surface
 If no is selected for any of this group, can a minor adjustment be made to make the bench dimensions compliant?
- Shelter Dimensions** Does the shelter meet these requirements:
 — Min 4' wide entry and exit points
 — Max height of 10' (recommended 10' by 4' by 7')
 If no is selected for any of this group, can a minor adjustment be made to make the shelter dimensions compliant?

IDENTIFY EXISTING BOARDING/ALIGHTING DIMENSIONS IN SKETCH BELOW **BELOW**

If applicable, shade out the missing concrete in the sketch and tabulate the costs

BUS PAD COST ESTIMATES

Sidewalk Concrete \$60.00 per SY
FL State Avg Cost 6" thick

NEW BUS PAD ESTIMATE

5' x 8' = 4.44 SY \$ 266.40

ACTUAL DIMENSIONS

Width: _____

Length: _____

Total SY: _____

Total SY Needed: _____

ESTIMATED COST: _____

ACCESSIBLE ROUTE EST.

ACCESSIBLE ROUTE EST.

*Measure Accessible Route

ACTUAL DIMENSIONS

Width: _____

Length: _____

Total SY: _____

ESTIMATED COST: _____

MIN SHELTER REQUIREMENTS

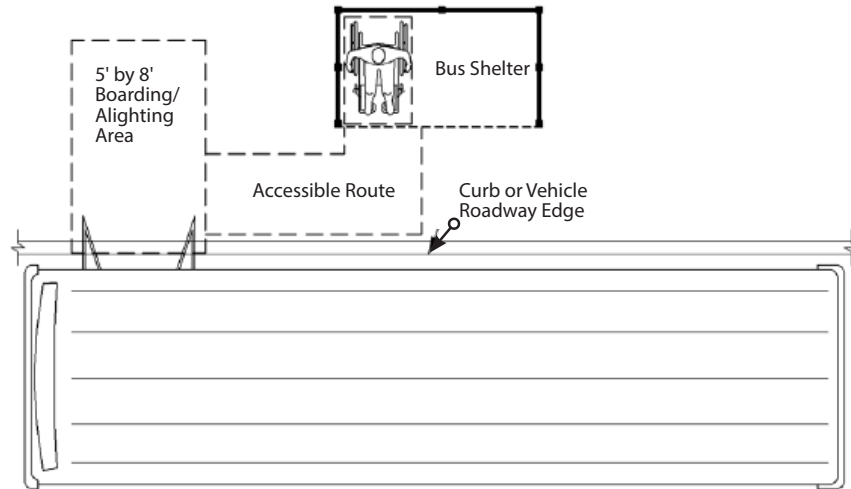

Source: ADA Standards for Accessible Design

Comments:



4 TRANSFER STOP REQUIREMENTS

Platform If there is a platform, does it have detectable warnings on the platform edges **24" wide**, extending the full length of the public use areas of the platform?
If no, can a minor adjustment be made to make this compliant?

Crosswalks If passengers must cross an intersection to transfer to another route, are crosswalks provided?
If no, can a minor adjustment be made to make this compliant?

Curb Ramps If there are crosswalks, do the crosswalks have ADA compliant curb ramps:
 — Counter slopes of adjoining gutters and road surfaces immediately adjacent to curb ramp not steeper than 1:20
 — Curb ramp flares shall not be steeper than 1:10
 — Landings at the tops of curb ramps with clear length of 36" and width at least as wide as the curb ramp
 — Curb ramps do not project into traffic lanes, parking spaces, or parking aisles
If no is selected for any of this group, can a minor adjustment be made to make the curb ramp compliant?

Detectable Warnings If there are sidewalks at intersecting roads connecting to the bus stop, do they have detectable warnings?
If no, can a minor adjustment be made to make this compliant?

Y	N	N/A

IDENTIFY EXISTING BOARDING/ALIGHTING DIMENSIONS IN SKETCH BELOW BELOW
If applicable, shade out the missing concrete in the sketch and tabulate the costs

CURB RAMP COST ESTIMATES

Sidewalk Concrete \$60.00 per SY
 FL State Avg Cost 6" thick

CURB RAMP ESTIMATE

*Measure Width of Curb Ramp

ACTUAL DIMENSIONS

Width: _____
 Length: _____
 Total SY: _____
 Total SY Needed: _____

ESTIMATED COST: _____

MIN CURB RAMP REQUIREMENTS

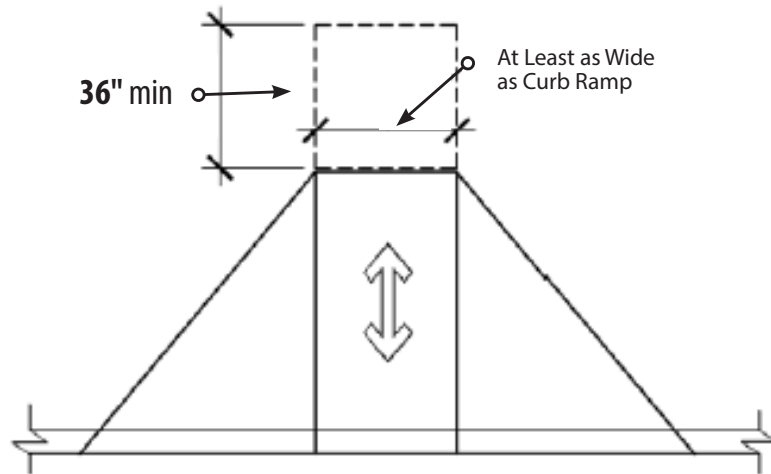

Source: ADA Standards for Accessible Design

Comments:

TOTAL STOP COST ESTIMATE

Total SY Needed: _____

ESTIMATED COST: _____



5 OTHER FEATURES TO DOCUMENT WITHIN 10' OF THE BUS STOP

Does a curb exist?	Is the stop close to curb cuts?	Is there an ADA ramp?	Does a ditch exist?
<input type="checkbox"/> Yes <input type="checkbox"/> No <input type="checkbox"/> N/A	<input type="checkbox"/> Yes <input type="checkbox"/> No <input type="checkbox"/> N/A	<input type="checkbox"/> Yes <input type="checkbox"/> No <input type="checkbox"/> N/A	<input type="checkbox"/> Yes <input type="checkbox"/> No <input type="checkbox"/> N/A
Comments	Comments	Comments	Comments
Are there crosswalks close to the stop?	Is there lighting and other safety features?	Does the intersection have pedestrian signals with audible devices?	Are there mid-block crossings?
<input type="checkbox"/> Yes <input type="checkbox"/> No <input type="checkbox"/> N/A	<input type="checkbox"/> Yes <input type="checkbox"/> No <input type="checkbox"/> N/A	<input type="checkbox"/> Yes <input type="checkbox"/> Yes, pedestrian signals without audible devices <input type="checkbox"/> No <input type="checkbox"/> N/A	<input type="checkbox"/> Yes <input type="checkbox"/> No <input type="checkbox"/> N/A
Comments	Comments	Comments	Comments

6 BUS STOP SUMMARY & CATEGORIZATION

Total ADA Elements Missing from Group 2	If there is a shelter, is it compliant with Group 4 or can be made compliant with minimum modification?		
If there is a bench, is it compliant with Group 3 or can be made compliant with minimum modification?	If it is a transfer point, is it compliant with group 5 or can be made compliant with minimum modification?		
Total Amount of ROW Available:	Can work be done in the ROW to make the Stop ADA compliant?	If work cannot be done, can the Stop be moved to a close, acceptable location?	Identify possible location:

ADA COMPLIANCE CATEGORIES (Check the appropriate category for the stop)

- **Category I:** Stop has all the elements identified on the checklist and is currently ADA compliant;
- **Category II:** Stop is missing one checklist item, and the work may be done within the existing Right-Of-Way (ROW);
- **Category III:** Stop is missing two to three elements and the work may be done within the existing ROW;
- **Category IV:** Stop is missing more than three elements and the work may be done within the existing ROW;
- **Category V:** Stop is missing more than three elements and/or there is insufficient ROW at the stop's current location. An accessible location, however, is located within an acceptable distance of the affected stop; and
- **Category VI:** Stop is missing more than three elements and/or there is insufficient ROW at the stop's current location. An alternate accessible location is NOT located within an acceptable distance of the affected stop.

ENCLOSURE G

ENCLOSURE G TPO AND TCC ONLY

SUBJECT: Update on the Escambia/Santa Rosa Regional Advanced Traffic Management System (ATMS) Feasibility Study and Implementation Plan, and Traffic Signalization Tasks of the Existing Joint Project Agreement (JPA)

ORIGIN OF SUBJECT: TPO Unified Planning Work Program (UPWP) Task C.3: ITS Planning

LOCAL GOVERNMENT ACTION NEEDED: None

BACKGROUND: Mr. Ben Faust, DRMP, will present an overview of the JPA contract accomplishments, including ATMS Phase 1 operations, signal retiming tasks, regional ATMS design and construction phases, and will discuss funding and implementation strategies for successful completion of a regional ATMS for Escambia and Santa Rosa counties. The regional ATMS shall incorporate various traffic signal system technologies, strategies and intelligent transportation systems (ITS) technologies in conformance with the national, statewide and regional architectures within both counties.

The JPA is between Escambia County and the state. This JPA provides funding for the regional traffic signal system operations, traffic engineering and transportation planning, and includes maintenance, continuous operation, and retiming of traffic signals.

RECOMMENDED ACTION: This item is for information only. Please contact Mr. John Alaghemand, DRMP, at 850-640-3904 or jalaghemand@drmp.com or Ms. Jill Lavender, ECRC staff, at 850 332-7976, Extension 212 or jill.lavender@ecrc.org if additional information is needed.

ENCLOSURE H

ENCLOSURE H ALL COMMITTEES

SUBJECT: Review of the Draft FL-AL TPO FY 2020-2024 Transportation Improvement Program (TIP)

ORIGIN OF SUBJECT: 23 Code of Federal Regulations Section 134(j), Chapter 339.175 (7) Florida Statutes, Florida–Alabama TPO Unified Planning Work Program (UPWP) Task C.1

LOCAL GOVERNMENT ACTION NEEDED: Provide regionally significant projects that have dedicated local funds between July 1, 2019 and June 30, 2024.

BACKGROUND: The TPO updates and adopts the TIP each year for submittal to FDOT, Federal Highway Administration (FHWA), and the Federal Transit Administration (FTA). Projects within the urbanized area must appear in the TIP in order to receive state and federal funding. ALDOT only requires the TIP be adopted every four years. However, since Florida adopts their TIPs annually, Alabama projects are also included annually in the Florida-Alabama TIP.

The FY 2020-2024 TIP process began in September 2018, when Project Priorities were adopted by the TPO and then submitted to FDOT. ALDOT does not require a separate Project Priority document. Priorities for ALDOT are required to only be submitted in the TIP. The Project Priorities are then used to develop the FDOT FY 2020-2024 Tentative Five-Year Work Program. The Tentative Five-Year Work Program is the primary source of information for the TIP. The FDOT Work Program and the TIP are consistent with the TPO's adopted priorities to the extent feasible. Projects are based on FDOT maintenance requirements, the TPO Long Range Transportation Plan (LRTP), Transportation Systems Management (TSM) studies, Transportation Alternatives Project (TAP) Priorities, and Aviation, Port, and Transit Master Plans. Projects listed in the TIP are subject to amendment as necessary by the TPO at any time during the year. The TIP has been developed through coordination with FDOT, ALDOT, and local governments.

The draft Florida-Alabama TPO FY 2020-2024 TIP will be posted online prior to the April 2019 TPO and advisory committee meeting. An e-mail with the draft TIP link on the TPO web site will be sent to the TPO and advisory committee members. The draft Florida-Alabama TPO FY 2020-2024 TIP Program will be accessible by clicking on the following link <ftp://ftp.wfrpc.org/TIP/FLAL>

The following are the Public Involvement elements for the Transportation Improvement Program:

- Inclusion of the review and adoption of the TIP in applicable TPO meeting advertisements
- Public forum at the TPO meeting when reviewing the TIP
- Public forum at the TPO meeting when requesting adoption of the TIP
- Provide the TIP document to the public and local agencies upon request
- Provide final document to local libraries of public access
- Interactive website is available and provide a link to it on the TPO website

Please provide all comments on the draft FL-AL TPO FY 2020-2024 TIP by close of business on Friday, April 26, 2019. Comments may be submitted to Mr. Gary Kramer at gary.kramer@ecrc.org at (850) 332-7976 Ext. 219.

RECOMMENDED ACTION: This item is for review this month and adoption in June. Please contact Mr. Gary Kramer, ECRC staff, at gary.kramer@ecrc.org or at (850) 332-7976 Ext. 219 if additional information is needed.

ENCLOSURE I

ENCLOSURE I

ALL COMMITTEES

SUBJECT: Overview of the Florida-Alabama TPO FY 2021-2025 Project Priorities Process and Schedule

ORIGIN OF SUBJECT: 23 Code of Federal Regulations Section 134(j), Chapter 339.175 (8)(b) Florida Statutes, Florida-Alabama TPO Unified Planning Work Program (UPWP) Task C.1

LOCAL GOVERNMENT ACTION NEEDED: None

BACKGROUND: Annually, the TPO reviews and adopts transportation project priorities in July for submittal to the Florida Department of Transportation (FDOT) by August 1st. This document is part of the Transportation Improvement Program (TIP) development process. Its purpose is to ensure that transportation projects programmed by FDOT in the Five-Year Work Program are consistent with local needs and plans for the TPO planning area.

As stated in the TPO Public Participation Process Plan dated April 2016, The Project Priorities result from the Long Range Transportation Plan's Cost Feasible Plan and are reviewed with the public and the TPO's advisory committees. Once approved by the TPO, the priorities are given to FDOT for creation of the Five-Year Work Program. From the Five-Year Work Program, the TPO develops the TIP which contains all transportation programs and projects scheduled during the next five years. The TIP is revised annually in June and is available, in interactive format, on the TPO's web site.

The Project Priorities and TIP must be developed by the TPO in consultation with all interested parties and, at a minimum, describe procedures, strategies, and desired outcomes for the following, as outlined by the Code of Federal Regulation (CFR 450.316) and the MPO Handbook:

- Providing reasonable public access to technical and policy information used;
- Providing adequate public notice of public involvement activities and time for public review and comment at key decisions, such as but not limited to the approval of the TIP/Project Priorities;
- Demonstrating explicit consideration and response to public input received during plan development process;
- Making the TIP and Project Priorities drafts and final documents available on the TPO website;
- Holding public meetings at convenient times and accessible locations;
- Seeking out and consider the needs of those traditionally underserved by existing transportation systems, including but not limited to, low-income and minority households;
- Coordinating with the statewide transportation planning public involvement and consultation processes under 23 C.F.R. Subpart B;
- Periodically reviewing the effectiveness of the procedures and strategies contained in the participation plan;
- When significant written and oral comments are received on a draft TIP or Project Priorities as a result of public involvement, a summary, analysis, and report on the disposition of comments shall be made part of the final documents;
- If the final Project Priorities/TIP differ significantly from the one made available for public comment or raises new material issues, an additional opportunity for public comment must be made available;
- When the Metropolitan Planning Area (MPA) includes Indian tribal lands, the TPO shall appropriately involve the Indian tribal government(s); and
- When the MPA includes federal public lands, the TPO shall appropriately involve the federal government.

General methods proven effective in previous Project Priorities and TIP public involvement efforts include:

- Providing the public with a sufficient opportunity to review the draft Project Priorities and TIP documents online;
- Promoting development of the Project Priorities and TIP through news releases, social media outlets and email blasts to TPO and advisory committee members as well as interested parties;
- Holding at least two public workshops for Project Priorities and TIP across the FL-AL TPO area unless an LRTP update is underway, in which case the Project Priorities and TIP would be discussed in conjunction with LRTP presentations;
- Coordinating public outreach to at least two additional community groups (with emphasis on the underserved) unless an LRTP update is underway, in which case the Project Priorities and TIP would be discussed in conjunction with LRTP presentations;
- Providing the public with a sufficient opportunity to review the draft Project Priorities and TIP documents online;
- Including public input collected at workshops in the draft Project Priorities and TIP;
- Including Project Priorities and TIP review in the advertisement of the TPO meeting when the draft Project Priorities and TIP are to be presented;
- Providing public with an opportunity to comment during public forum when the draft Project Priorities and TIP are presented for review to the TPO and advisory committees;
- Including adoption in the advertisement of the TPO meeting when final draft Project Priorities and TIP are to be presented;
- Providing public with an opportunity to comment during public forum when the draft Project Priorities and TIP are presented for adoption to the TPO and advisory committees; and
- Publishing adopted TIP interactive site and final Project Priorities document on web site.

TPO responsibilities require that all modes of transportation be addressed in the Project Priorities. The following categories of projects are included in the Priorities:

1. Long Range Transportation Plan Capacity Projects
2. Transportation Systems Management Projects
3. Bicycle/Pedestrian Related Projects
4. Public Transportation Projects
5. Aviation Projects
6. Seaport Projects
7. Bridge Replacement Projects
8. Congestion Mitigation and Air Quality Projects

The draft Project Priorities for FY 2021-2025 project schedule is listed below:

- April 8, 2019- TCC meeting to present Project Priorities schedule (Pensacola City Hall)
- April 9, 2019- CAC meeting to present Project Priorities schedule (Pensacola City Hall)
- April 10, 2019- TPO meeting to present Project Priorities schedule (Tiger Point Community Center)
- May 2019- Public outreach event
- May 20 19- Public outreach event
- May 2019- Public workshop
- May 2019- TPO/TCC/CAC workshop
- June 10, 2019- TCC meeting to present draft FY 2021-2025 Project Priorities (Pensacola City Hall)
- June 11, 2019- CAC meeting to present draft FY 2021-2025 Project Priorities (Pensacola City Hall)
- June 12, 2019- TPO meeting to present draft FY 2021-2025 Project Priorities (West Florida Regional Library)
- June 2019- TPO/TCC/CAC workshop
- July 8, 2019- TCC meeting to recommend approval of FY 2021-2025 Project Priorities (Pensacola City Hall)
- July 9, 2019- CAC meeting to recommend approval of FY 2021-2025 Project Priorities (Pensacola City Hall)

- July 10, 2019- TPO meeting to recommend approval of FY 2021-2025 Project Priorities Tiger Point Community Center

RECOMMENDED ACTION: This item is for review this month and June and adoption in July. Please contact Mr. Gary Kramer, ECRC staff, if additional information is needed at gary.kramer@ecrc.org or (850) 332-7976 Ext. 219.

ENCLOSURE J

ENCLOSURE J ALL COMMITTEES

SUBJECT: Review of the Draft Florida-Alabama Transportation Planning Organization (FL-AL TPO) Public Participation Plan (PPP) Major Update

ORIGIN OF SUBJECT: Fixing America's Surface Transportation (FAST) Act, Moving Ahead for Progress in the 21st Century (MAP-21), Code of Federal Regulation (CFR 450.316) and the Florida MPO Handbook

LOCAL GOVERNMENT ACTION NEEDED: None

BACKGROUND: The PPP provides guidelines for achieving quality public involvement when developing major planning documents and programs. Effective public participation begins early in the planning process and continues throughout, helping to avoid, minimize, and mitigate negative project impacts while providing the best solutions. The primary goals of the PPP are to:

- **Inform the Public**
Inform the public, to the maximum extent possible with available resources, of opportunities to participate in the transportation decision-making process
- **Involve the Public**
Involve the public early and often in the transportation planning process
- **Include the Public**
Reach out to the geographical, organizational and demographic communities that compose the TPO planning area to increase the opportunity to participate in developing transportation plans and services
- **Improve the Public Participation Process**
Continually identify and implement ways to improve the public participation processes

The PPP is reviewed as part of the four-year certification process conducted by the Federal Highway Administration (FHWA) and Federal Transit Administration (FTA) during the TPO certification.

The TPO adopted the current PPP in September 2018 with the understanding that changes, edits, and revisions would be made after an appropriate timeframe. The PPP has had major updates due to feedback from the 2018 federal certification review. This plan is under a 45-day review period beginning April 8, 2019. **Please provide all comments by 5 p.m. on May 24, 2019**

The draft PPP can be viewed under the following link: [Public Participation Plan FINAL DRAFT](#)

Comments will be documented, addressed, and presented to the Florida-Alabama TPO by staff. Submit comments by **5 p.m. on May 24, 2019** for consideration to Public Involvement Coordinator, Ms. Brittany Ellers, at (850) 332-7976, ext. 220 or brittany.ellers@ecrc.org.

RECOMMENDED ACTION: This item is for review and comment. Adoption will be requested in June. Please have ALL final comments submitted no later than **5 p.m. on May 24, 2019**. Please contact Ms. Brittany Ellers, ECRC Public Involvement Coordinator, at (850) 332-7976, Extension 220 or brittany.ellers@ecrc.org if additional information is needed.

ENCLOSURE K

ENCLOSURE K ALL COMMITTEES

SUBJECT: Fifth Annual Emerald Coast Transportation Symposium Update

ORIGIN OF SUBJECT: Staff

LOCAL GOVERNMENT ACTION NEEDED: None

BACKGROUND: Each year, the Emerald Coast Regional Council hosts the Emerald Coast Transportation Symposium. The fifth annual symposium was postponed due to Hurricane Michael and was held on February 25-26, 2019 in Navarre, Florida. Staff will update the TPO board and advisory committees on the symposium.

RECOMMENDED ACTION: This item is for information only. Please contact Ms. Kathy Saldana, ECRC Public Involvement Manager, if additional information is needed at kathy.saldana@ecrc.org or (850) 332-7976 Ext. 204.

ENCLOSURE L

ENCLOSURE L ALL COMMITTEES

SUBJECT: Information Items (No Presentation Necessary)

ORIGIN OF SUBJECT: ECRC Staff

LOCAL GOVERNMENT ACTION NEEDED: None

Attached are the following:

- TCC and CAC February Meeting Minutes
- FL-AL TPO February Actions Report
- FDOT Changes to the Tentative Work Program for FY 2020-2023
- FDOT Transportation Improvement Program (TIP) Modification Letters
- 2019 FL-AL TPO Schedule

RECOMMENDED ACTION: This item is for information. Please contact Ms. Tiffany Bates, ECRC staff, at 1-800-226-8914 Extension 217 or tiffany.bates@ecrc.org if additional information is needed.

**FLORIDA, ALABAMA TRANSPORTATION PLANNING ORGANIZATION
TECHNICAL COORDINATING COMMITTEE (TCC) MINUTES**

WEST FLORIDA REGIONAL PLANNING COUNCIL (Designated staff)

Pensacola City Hall, 222 West Main Street, Pensacola, Florida 32502

February 11, 2019

Members in Attendance:

Griffin Powell, Chair	City of Orange Beach
Samantha Abell, Vice Chair	City of Gulf Breeze
Tonya Ellis	Escambia County Transit
Terri V. Malone	Escambia County
John Fisher	Escambia County
Leslie Statler	City of Pensacola
M Helen Gibson	City of Pensacola
Amy Miller	Port of Pensacola
Mike Hamlin	ECUA
Ryan Novota	City of Pensacola
Max Rogers	CRA

Members Not in Attendance:

John Dosh	Escambia County
Sarah C Hart	Baldwin County
Andrea Levitt Kvech	Pensacola Airport
Cassie C Boatwright	Purchasing and Auxiliary Services
Chip Chism	University of West Florida
Chris Phillips	Santa Rosa County
Derrick Owens	City of Pensacola
Glenn C Griffith	Brownfields Coordinator
Horace Jones	Escambia County
Jud Crane	Santa Rosa County
Morgan Lamb	Santa Rosa Bay Bridge Authority
Stephen L Furman	Santa Rosa County
Steve Opalenik	Pensacola Naval Air Station
Taylor Rider	Baldwin County
Vince Jackson	Baldwin County
Randy Jorgenson	City of Milton
Steve Harrell	Escambia County

Others in Attendance

Bryant Paulk	FDOT
Christy Johnson	FDOT
Cory Wilkinson	HDR
David Forte	Escambia County
Chandra Middleton	Baldwin County Commission
Barbara Mayall	Citizen
Jenny Cook	City of Milton
Ann Hill	Pensacola City Council
Dottie Dabinson	

West Florida Regional Planning Council Staff

Gary Kramer
Tiffany Bates
Jill Lavender
Gabrielle Merritt
Rob Mahan
Kristen Barre

A. CALL TO ORDER / PLEDGE / INVOCATION

Mr. Powell called the meeting to order.

B. APPROVAL OF AGENDA

Ms. Bates stated that an incorrect scope was put into Enclosure G but that a corrected copy was provided.

Ms. Abell moved to approve the February 2019 FL-AL Technical Coordinating Committee agenda. Ms. Miller seconded the motion and it was unanimously approved.

C. PUBLIC FORUM

There were no speakers from the public.

D. FHWA/FDOT/ALDOT PRESENTATIONS/UPDATES:

- 1. ENCLOSURE A- TPO ONLY: FEDERAL HIGHWAY ADMINISTRATION (FHWA):**
Presentation of Certification Results by Federal Highway Administration (FHWA) and Federal Transit Administration (FTA) Ms. Cathy Kendall, AICP, FWHA Florida Division Planning Team Leader
- 2. ENCLOSURE B- TPO ONLY: ALABAMA DEPARTMENT OF TRANSPORTATION (ALDOT)**
Consideration to Authorize the Chairman to Sign an Infrastructure for Rebuilding America (INFRA) Grant Application Support Letter for I-10 Congestion Relief, Mobile River Bridge and Bayway Project- Mr. Matthew Ericksen, P.E., ALDOT Mobile River Bridge & Bayway Project Director
- 3. ALDOT UPDATE: Mr. Vincent Beebe, P.E., Alabama Department of Transportation (ALDOT)**

Mr. Gary Kramer stated that Vince Beebe is in Montgomery this week and apologizes for not being able to attend the TPO and advisory committees this month. Mr. Kramer provided the briefing of 4 projects in the Orange Beach area and said he will provide any follow-up information on the projects if necessary.

Utilities are currently being relocated for the SR-180 (Canal Road) Widening from Foley Beach Express to SR-161 (Orange Beach Boulevard) project. Plans for roadway construction are expected to be bid and let on April 26, 2019.

Plans are approximately 60% complete and ALDOT is working to obtain ROW for the SR-180 (Canal Road) at SR-161 (Orange Beach Boulevard) Intersection Improvement (Curve project) project. The project is expected to be let for construction in Early 2020.

Mr. Kramer reported that mainline paving has been completed for the SR-182 (Perdido Beach Boulevard) resurfacing project from Perdido Pass Bridge to the AL-FL state line. ALDOT is finalizing driveway and side street tie-in paving and final roadway paint will be applied in approximately 2 weeks.

Mr. Kramer gave an update on the new roadway and bridge from SR-180 (Canal Rd.) to Foley Beach Express (FBE) also known as the "Waterways" project. Mr. Kramer stated that ALDOT is working with the Corps of Engineers and Coast Guard to obtain environmental clearances / permits. Plan revisions are being considered based on public comments received during the public involvement meeting. The current schedule will likely allow the northern roadway portion to be let for construction before the bridge portion. Utility and right-of-way coordination are ongoing.

4. FDOT UPDATE: Mr. Bryant Paulk, AICP, or Ms. Christy Johnson, AICP, Florida Department of Transportation (FDOT) Urban Liaisons

Mr. Paulk stated that he only had one item to update the committee on. Mr. Paulk stated that Mr. Kevin J. Thibault had been chosen as the new Secretary of the Florida Department of Transportation. Mr. Paulk stated that Mr. Thibault has extensive experience in the private and public sectors and has previously served for many years at FDOT. Mr. Paulk added that he also has extensive experience in state government, having previously served in senior leadership positions with the Florida Department of Transportation for more than 16 years.

E. CONSENT: ALL COMMITTEES: Approval of December 2018 Meeting Minutes.

Ms. Ellis moved to approve the 2018 December meeting minutes. Ms. Statler seconded the motion and it passed unanimously.

F. ACTION:

- 1. ENCLOSURE C- ALL COMMITTEES Consideration of Resolution FL-AL 19-02 to Approve the Scope of Services for the Florida-Alabama TPO 2045 Long Range Transportation Plan Update- Mr. Gary Kramer, WFRPC Staff.**

Mr. Kramer presented the Scope of Services for the Florida-Alabama TPO 2045 Long Range Transportation Plan update. Mr. Kramer stated that this action is recommended to begin the Long-Range Plan update as soon as possible in order meet the November 3, 2020 adoption date.

Ms. Malone moved to recommend the TPO authorize the TPO chairman to sign Resolution FL-AL 19-02 to approve the scope of services for the Florida-Alabama TPO 2045 Long Range Transportation Plan update. Ms. Gibson seconded the motion and it was unanimously approved.

2. ENCLOSURE D- ALL COMMITTEES Consideration of Resolution FL-AL 19-03 Adopting the Transportation Alternatives (TA) Set-Aside Ranked Projects- Ms. Kristen Barre', WFRPC Staff.

Ms. Barre' presented the Transportation Alternatives (TA) Set-Aside ranked projects. Ms. Barre' stated that a total of 11 applications from the Florida-Alabama TPO area were submitted by the January 4, 2019 deadline and the applications were ranked according to adopted ranking criteria. Ms. Barre' gave a brief background on the project scoring criteria and the requirements.

Ms. Abell stated that she recognized all the projects' importance but did not understand why the Fairpoint-Shoreline multi-use path in Gulf Breeze was ranked so low when last time it was submitted, it was ranked 2nd. Ms. Abell stated that this loop was imperative for better quality of life within Gulf Breeze. Ms. Abell added that it is the number one priority of the citizens and is recognized in the comprehensive plan and all major planning documents. Ms. Abell stated that it is the only thing that Gulf Breeze has asked for to alleviate the issues that are going to come with the increased motorized vehicles coming into Gulf Breeze, due to the new bridge. Ms. Abell asked that in consideration of the TPO ranking this project as the second highest project last year, that the TCC consider modifying the list to recognize the importance of this project as it relates to 55,000 motorists who drive through the Gulf Breeze community daily.

Ms. Gibson stated that the top two projects are in the community redevelopment area, which are the low-income areas where connectivity and safety are a real big issue. There is a school where the kids cannot walk to due to the major highways which is a major quality of life for the residents of those communities. Ms. Abell asked Ms. Gibson if they had submitted CRA funds to match. Ms. Gibson said they have, and that they are applying for a Safe Route to School grant as well. Ms. Abell stated that for the loop in gulf breeze, there are not alternative forms of funding. Ms. Abell expressed her concern about how a small community with a very large problem will ever get support. Ms. Ellis stated that it would have been helpful to have the breakdown of each criterion included in the agenda packet.

Ms. Abell stated that in reviewing the criterion that was attached, the individual projects rankings are not attached, so it was difficult to see how certain projects weighed out compared to others. Ms. Abell stated that there is no argument to the unbiased and technical approach to the rankings. Ms. Abell explained that the Gulf Breeze Fairpoint-Shoreline multi-use path is the best chance for the residents to try to escape through traffic every day.

Ms. Miller stated that she trusts that staff applied the criteria and the scoring process fairly and equitably to each of the projects. She stated that she would like to move forward with the set list as presented by staff.

Ms. Abell stated that she was trying to figure out why there was such a variation between the last time the project was submitted compared to now. Ms. Barre' stated that there were new projects submitted that ranked higher.

There was discussion of a motion that would recommend the TPO receive the full rankings and scoring of each individual project so that they could see how each project scored in each criterion. Ms. Abell suggested that in the future, TCC members be sent the full list more in advance so that the rankings can be evaluated, and further input can be made. There was discussion in bringing back a workshop that use to be held prior to the list being presented, that would allow city and county staffs to evaluate each application before the meeting.

Ms. Ellis stated that she needed to have all the data and information in front of her before she could give her support.

Mr. Novota moved to recommend the TPO authorize the TPO chairman to sign Resolution FL-AL 19-03 adopting the Transportation Alternatives (TA) Set-aside ranked projects and to have staff provide the TPO with all the backup of the scoring process. Mr. Rogers seconded the motion. The motion passed with one opposed.

There was further discussion about a motion supporting a workshop. Ms. Bates stated that staff would bring that recommendation back to the TPO.

- 3. ENCLOSURE E- ALL COMMITTEES Consideration of Resolution FL-AL 19-05 Approving TPO Staff to Coordinate with the City of Pensacola and Escambia County Staff to Finalize a Scope of Services and Enter into a Contract with the TPO's General Planning Consultant for the West Cervantes Street Corridor Traffic Feasibility Study- Ms. Jill Lavender, WFRPC Staff.**

Ms. Lavender stated that at the TPO's December 12, 2018 meeting, FDOT staff recommended that the county and city allow the TPO's general planning consultant to perform the study. On January 10, 2019, the Escambia County Board of County Commissioners approved a resolution supporting the FDOT's recommendation to retain the TPO's general planning consultant to perform the West Cervantes Street Corridor Traffic Feasibility Study.

Ms. Malone moved to recommend the TPO authorize the TPO chairman to sign Resolution FL-AL 19-50 approving TPO staff to coordinate with the City of Pensacola and Escambia County staff to finalize a scope of services and enter into a contract with the TPO's general planning consultant for the West Cervantes Street Corridor Traffic Feasibility Study. Ms. Miller seconded the motion and it was unanimously approved.

- 4. ENCLOSURE F- ALL COMMITTEES Consideration of Resolution FL-AL 19-01 to Adopt Targets for Safety Performance Measures- Mr. Gary Kramer, WFRPC Staff**

Mr. Kramer presented and stated that this action is recommended to comply with the February 27, 2019 deadline to remain in compliance with the federal and state regulations for transportation planning. Mr. Kramer stated that the board could either move forward with the state's target or establish their own. Mr. Kramer stated that during the December TPO and advisory committee meetings, the members were advised that if there was desire to set targets for Safety which are different from FDOT and ALDOT, comments were to be emailed by December 19, 2018. Mr. Kramer stated that no e-mails were received by that deadline.

Ms. Malone moved to recommend the TPO authorize the TPO chairman to sign Resolution FL-AL 19-01 to adopt targets for Safety Performance Measures. Ms. Statler seconded the motion and it was unanimously approved.

5. **ENCLOSURE G- ALL COMMITTEES Consideration of Resolution FL-AL 19-04 to Sign Notice to Proceed for Escambia County Area Transit (ECAT) Bus Stop Assessment Plan- Mr. Rob Mahan, WFRPC Staff.**

Mr. Mahan stated that this action is recommended to comply with ADA Bus Stop accessibility requirements. Mr. Mahan explained that the FTA requires providers of fixed route service to have a plan to bring bus stops into ADA compliance and to actively implement that plan. During development of the TPO's State Fiscal Year 2019 Unified Planning Work Program (UPWP), ECAT and TPO staff discussed programming \$65,000 of the TPO's public transportation planning funds in the FY 2019 UPWP for the TPO's general planning consultant to develop a Bus Stop Assessment Plan that would evaluate the ADA compliance of all ECAT stops and create a plan to bring non-compliant stops into compliance.

Mr. Mahan stated that the TPO's general planning consultant developed a scope of services for this project and TPO staff developed a Notice to Proceed, the Task Work Order, and UPWP task budget showing the \$65,000 budgeted for consulting services.

Ms. Miller moved to recommend the TPO authorize the TPO chairman to sign Resolution to Proceed for the TPO's general planning consultant, HDR to develop a Bus Stop Assessment Plan according to the attached Task Work Order. Ms. Statler seconded the motion and it was unanimously approved.

- G. **WEST FLORIDA REGIONAL PLANNING COUNCIL EXECUTIVE DIRECTOR'S REPORT- TPO ONLY- Mr. Austin Mount, WFRPC Executive Director.**

H. **MULTI MODAL UPDATE**

Ms. Miller gave a brief update on the Port of Pensacola. She stated that there was going to be a Florida- Alabama Freight Advisory Working Group meeting held on February 28th that included a port tour. Ms. Miller stated that construction on the downtown Pensacola Ferry landing is nearing completion.

Ms. Miller stated that the port submitted the final draw on a 2-million-dollar economic development transportation grant to put an overhead crane facility in one of the warehouses on the port. On January 7th, the sixth rehabilitation project began, which is about a 2.5-million-dollar phase of a three phase ten-million-dollar project. Ms. Miller stated that the final report from the port study should be out soon.

I. **PRESENTATIONS (no action):**

1. **ENCLOSURE H- ALL COMMITTEES Review of Draft Fiscal Year (FY) 2020 Unified Planning Work Program (UPWP) (Year 2)- Ms. Mary Beth Washnock, WFRPC Transportation Planning Manager.**

Ms. Bates stated that the Florida-Alabama TPO UPWP defines the tasks, activities, responsible parties, and anticipated budget for planning activities to be undertaken in the MPA served by the TPO for FY 2019 (July 1, 2018-June 30, 2019) and FY 2020 (July 1, 2019-June 30, 2020.) TPO members, advisory committee members, staff, and the public are encouraged to review the new two-year UPWP for any potential updates and revisions. Ms. Bates informed the board that **comments are due by March 15, 2019**. Ms. Bates stated that the link to the DRAFT UPWP was sent out separately in an email.

2. ENCLOSURE I- TPO ONLY Citizens' Advisory Committee (CAC) Appointment Process- Ms. Brittany Ellers, WFRPC Staff.

J. INFORMATION ITEMS (no presentation necessary)

1. ENCLOSURE J- ALL COMMITTEES

- TCC and CAC December Meeting Minutes
- FL-AL TPO December Actions Report
- FDOT Changes to the Tentative Work Program for FY 2020-2024
- FDOT Transportation Improvement Program (TIP) Modification Letters
- Note of Appreciation from Britney Moore, Florida Greenways and Trails
- 2019 FL-AL TPO Schedule

K. OTHER BUSINESS- - The next Florida-Alabama TPO meeting will be Wednesday, April 10, 2019 at 9:00 a.m. at the Tiger Point Community Center, Gulf Breeze, Florida. Advisory committee meetings are to be held at Pensacola City Hall, 222 West Main Street, Pensacola, Florida 32502. TCC will meet on Monday, April 8, 2019 at 8:30 a.m. The CAC will meet on Tuesday, April 9, 2019 at 3:00 p.m.

L. ADJOURNMENT

The meeting was adjourned at 10:45 P.M.

**FLORIDA- ALABAMA TRANSPORTATION PLANNING ORGANIZATION
CITIZENS ADVISORY COMMITTEE (CAC) MINUTES**

WEST FLORIDA REGIONAL PLANNING COUNCIL (Designated staff)

Pensacola City Hall, 222 West Main Street, Pensacola, Florida 32502

February 12, 2019

Members in Attendance:

Vernon Compton
Anne B. Bennett
Barbara Mayall
Sean Bullington
Jim Roberts
Kurt Larson
Patrick M. McClellan
Bill Jeffries
Sandy Boyd

Members Not in Attendance:

Robin Edwards
Terry Miller
Mike Kilmer
Lisa Walsh

Others in Attendance

Christy Johnson	FDOT
Cory Wilkinson	HDR
David Forte	Escambia County
Chandra Middleton	Baldwin County Commission
Barbara Mayall	Citizen
Ann Hill	Pensacola City Council
Sherri Myers	Pensacola City Council

West Florida Regional Planning Council Staff

Mary Beth Washnock
Gary Kramer
Tiffany Bates
Jill Lavender
Gabrielle Merritt
Rob Mahan
Kristen Barre

A. CALL TO ORDER / PLEDGE / INVOCATION

Mr. Compton called the meeting to order.

B. APPROVAL OF AGENDA

Ms. Bates stated that an incorrect scope was put into Enclosure G but that a corrected copy was provided.

Mr. Bullington moved to approve the February 2019 FL-AL Technical Coordinating Committee agenda. Ms. Mayall seconded the motion and it was unanimously approved.

C. PUBLIC FORUM

Ms. Sherri Myers, Pensacola City Councilwoman, spoke regarding her concerns of the lack of attention to the safety issue and lack of lighting on 9th Avenue, specifically the northern portion. Councilwoman Myers stated that 9th Avenue is the longest street in Pensacola with a large amount of small businesses and residential areas. Councilwoman Myers added that Sacred Heart hospital is also located on 9th Avenue and that the hospital is the largest tax payer in the City of Pensacola and the third largest employer in Escambia County. She stated that the needs of 9th Avenue are ignored by the city and FDOT. Councilwoman Myers stated that she and a few citizens made a live stream video of themselves trying to cross 9th Avenue at Brent Lane while it was dark outside. Councilwoman Myers stated that the video shows that it was nearly impossible to see when crossing 9th Avenue due to the lack of street lighting.

D. FHWA/FDOT/ALDOT PRESENTATIONS/UPDATES:

- 1. ENCLOSURE A- TPO ONLY: FEDERAL HIGHWAY ADMINISTRATION (FHWA): Presentation of Certification Results by Federal Highway Administration (FHWA) and Federal Transit Administration (FTA) Ms. Cathy Kendall, AICP, FWHA Florida Division Planning Team Leader**
- 2. ENCLOSURE B- TPO ONLY: ALABAMA DEPARTMENT OF TRANSPORTATION (ALDOT) Consideration to Authorize the Chairman to Sign an Infrastructure for Rebuilding America (INFRA) Grant Application Support Letter for I-10 Congestion Relief, Mobile River Bridge and Bayway Project- Mr. Matthew Ericksen, P.E., ALDOT Mobile River Bridge & Bayway Project Director**
- 3. ALDOT UPDATE: Mr. Vincent Beebe, P.E., Alabama Department of Transportation (ALDOT)**

Mr. Gary Kramer stated that Vince Beebe is in Montgomery this week and apologizes for not being able to attend the TPO and advisory committees this month. Mr. Kramer provided the briefing of 4 projects in the Orange Beach area and said he will provide any follow-up information on the projects if necessary. Utilities are currently being relocated for the SR-180 (Canal Road) Widening from Foley Beach Express to SR-161 (Orange Beach Boulevard) project. Plans for roadway construction are expected to be bid and let on April 26, 2019.

Plans are approximately 60% complete and ALDOT is working to obtain ROW for the SR-180 (Canal Road) at SR-161 (Orange Beach Boulevard) Intersection Improvement (Curve project) project. The project is expected to be let for construction in early 2020. Mr. Kramer reported that mainline paving has been completed for the SR-182 (Perdido Beach Boulevard) resurfacing project from Perdido Pass Bridge to the AL-FL state line. ALDOT is finalizing driveway and side street tie-in paving and final roadway paint will be applied in approximately 2 weeks.

Mr. Kramer gave an update on the new roadway and bridge from SR-180 (Canal Rd.) to Foley Beach Express (FBE) also known as the "Waterways" project. Mr. Kramer stated that ALDOT

is working with the Corps of Engineers and Coast Guard to obtain environmental clearances/permits. Plan revisions are being considered based on public comments received during the public involvement meeting. The current schedule will likely allow the northern roadway portion to be let for construction before the bridge portion. Utility and right-of-way coordination are ongoing.

4. FDOT UPDATE: Mr. Bryant Paulk, AICP, or Ms. Christy Johnson, AICP, Florida Department of Transportation (FDOT) Urban Liaisons

Ms. Johnson stated that she only had one item to update the committee on. Mr. Johnson stated that Mr. Kevin J. Thibault had been chosen as the new Secretary of the Florida Department of Transportation. Ms. Johnson stated that Mr. Thibault has extensive experience in the private and public sectors and has previously served for many years at FDOT. Ms. Johnson added that he also has extensive experience in state government, having previously served in senior leadership positions with the Florida Department of Transportation for more than 16 years.

There was discussion about the Theo Baars Bridge and the need for improvements. Mr. McClellan asked about the safety study conducted on the bridge. Ms. Johnson stated that the bridge is being inspected later this month and that she will come back and let the CAC know the results of the inspection. Ms. Johnson stated that at the last inspection, it was close to the cut off for needing replacement. Ms. Johnson stated that because it is up for possible replacement in the future, it is not a candidate for any multi modal improvements.

E. CONSENT: ALL COMMITTEES: Approval of December 2018 Meeting Minutes.

Mr. Jeffries stated that he was not included in the December 2018 attendance. Ms. Bates stated that he would be added, and the minutes would be amended.

Mr. Bullington moved to approve the 2018 December meeting minutes as amended. Mr. McClellan seconded the motion and it passed unanimously.

F. ACTION:

- 1. ENCLOSURE C- ALL COMMITTEES Consideration of Resolution FL-AL 19-02 to Approve the Scope of Services for the Florida-Alabama TPO 2045 Long Range Transportation Plan Update- Mr. Gary Kramer, WFRPC Staff.**

Mr. Kramer presented the Scope of Services for the Florida-Alabama TPO 2045 Long Range Transportation Plan update. Mr. Kramer stated that this action is recommended to begin the Long-Range Plan update as soon as possible in order meet the November 3, 2020 adoption date.

Ms. Mayall moved to recommend the TPO authorize the TPO chairman to sign Resolution FL-AL 19-02 to approve the scope of services for the Florida-Alabama TPO 2045 Long Range Transportation Plan update. Mr. Roberts seconded the motion and it was unanimously approved.

2. **ENCLOSURE D- ALL COMMITTEES Consideration of Resolution FL-AL 19-03 Adopting the Transportation Alternatives (TA) Set-Aside Ranked Projects- Ms. Kristen Barre', WFRPC Staff.**

Ms. Barre' presented the Transportation Alternatives (TA) Set-Aside ranked projects. Ms. Barre' stated that a total of 11 applications from the Florida-Alabama TPO area were submitted by the January 4, 2019 deadline and the applications were ranked according to adopted ranking criteria. Ms. Barre' gave a brief background on the project scoring criteria and the requirements.

Ms. Mayall stated that she attended the TCC and recommended echoing the TCC's actions and forwarding the list along to the TPO as presented.

Ms. Mayall moved to recommend the TPO authorize the TPO chairman to sign Resolution FL-AL 19-03 adopting the Transportation Alternatives (TA) Set-aside ranked projects. Mr. Roberts seconded the motion. The motion passed with one opposed.

3. **ENCLOSURE E- ALL COMMITTEES Consideration of Resolution FL-AL 19-05 Approving TPO Staff to Coordinate with the City of Pensacola and Escambia County Staff to Finalize a Scope of Services and Enter into a Contract with the TPO's General Planning Consultant for the West Cervantes Street Corridor Traffic Feasibility Study- Ms. Jill Lavender, WFRPC Staff.**

Ms. Lavender stated that at the TPO's December 12, 2018 meeting, FDOT staff recommended that the county and city allow the TPO's general planning consultant to perform the study. On January 10, 2019, the Escambia County Board of County Commissioners approved a resolution supporting the FDOT's recommendation to retain the TPO's general planning consultant to perform the West Cervantes Street Corridor Traffic Feasibility Study.

Mr. Roberts moved to recommend the TPO authorize the TPO chairman to sign Resolution FL-AL 19-50 approving TPO staff to coordinate with the City of Pensacola and Escambia County staff to finalize a scope of services and enter into a contract with the TPO's general planning consultant for the West Cervantes Street Corridor Traffic Feasibility Study. Ms. Mayall seconded the motion and it was unanimously approved.

4. **ENCLOSURE F- ALL COMMITTEES Consideration of Resolution FL-AL 19-01 to Adopt Targets for Safety Performance Measures- Mr. Gary Kramer, WFRPC Staff**

Mr. Kramer presented and stated that this action is recommended to comply with the February 27, 2019 deadline to remain in compliance with the federal and state regulations for transportation planning. Mr. Kramer stated that the board could either move forward with the state's target or establish their own. Mr. Kramer stated that during the December TPO and advisory committee meetings, the members were advised that if there was desire to set targets for Safety which are different from FDOT and ALDOT, comments were to be emailed by December 19, 2018. Mr. Kramer stated that no e-mails were received by that deadline.

Ms. Bennet moved to recommend the TPO authorize the TPO chairman to sign Resolution FL-AL 19-01 to adopt targets for Safety Performance Measures. Ms. Mayall seconded the motion and it was unanimously approved.

5. **ENCLOSURE G- ALL COMMITTEES Consideration of Resolution FL-AL 19-04 to Sign Notice to Proceed for Escambia County Area Transit (ECAT) Bus Stop Assessment Plan- Mr. Rob Mahan, WFRPC Staff.**

Mr. Mahan stated that this action is recommended to comply with ADA Bus Stop accessibility requirements. Mr. Mahan explained that the FTA requires providers of fixed route service to have a plan to bring bus stops into ADA compliance and to actively implement that plan. During development of the TPO's State Fiscal Year 2019 Unified Planning Work Program (UPWP), ECAT and TPO staff discussed programming \$65,000 of the TPO's public transportation planning funds in the FY 2019 UPWP for the TPO's general planning consultant to develop a Bus Stop Assessment Plan that would evaluate the ADA compliance of all ECAT stops and create a plan to bring non-compliant stops into compliance.

Mr. Mahan stated that the TPO's general planning consultant developed a scope of services for this project and TPO staff developed a Notice to Proceed, the Task Work Order, and UPWP task budget showing the \$65,000 budgeted for consulting services.

Mr. Larson moved to recommend the TPO authorize the TPO chairman to sign Resolution to Proceed for the TPO's general planning consultant, HDR to develop a Bus Stop Assessment Plan according to the attached Task Work Order. Mr. Bullington seconded the motion and it was unanimously approved.

- G. **WEST FLORIDA REGIONAL PLANNING COUNCIL EXECUTIVE DIRECTOR'S REPORT- TPO ONLY- Mr. Austin Mount, WFRPC Executive Director.**

- H. **MULTI MODAL UPDATE**
There was no update given.

- I. **PRESENTATIONS (no action):**

1. **ENCLOSURE H- ALL COMMITTEES Review of Draft Fiscal Year (FY) 2020 Unified Planning Work Program (UPWP) (Year 2)- Ms. Mary Beth Washnock, WFRPC Transportation Planning Manager.**

Ms. Washnock stated that the Florida-Alabama TPO UPWP defines the tasks, activities, responsible parties, and anticipated budget for planning activities to be undertaken in the MPA served by the TPO for FY 2019 (July 1, 2018-June 30, 2019) and FY 2020 (July 1, 2019-June 30, 2020.) TPO members, advisory committee members, staff, and the public are encouraged to review the new two-year UPWP for any potential updates and revisions. Ms. Washnock informed the board that **comments are due by March 15, 2019**. Ms. Washnock stated that the link to the DRAFT UPWP was sent out separately in an email.

2. **ENCLOSURE I- TPO ONLY Citizens' Advisory Committee (CAC) Appointment Process- Ms. Brittany Ellers, WFRPC Staff.**

J. INFORMATION ITEMS (no presentation necessary)

1. ENCLOSURE J- ALL COMMITTEES

- TCC and CAC December Meeting Minutes
- FL-AL TPO December Actions Report
- FDOT Changes to the Tentative Work Program for FY 2020-2024
- FDOT Transportation Improvement Program (TIP) Modification Letters
- Note of Appreciation from Britney Moore, Florida Greenways and Trails
- 2019 FL-AL TPO Schedule

K. OTHER BUSINESS- - The next Florida-Alabama TPO meeting will be Wednesday, April 10, 2019 at 9:00 a.m. at the Tiger Point Community Center, Gulf Breeze, Florida. Advisory committee meetings are to be held at Pensacola City Hall, 222 West Main Street, Pensacola, Florida 32502. TCC will meet on Monday, April 8, 2019 at 8:30 a.m. The CAC will meet on Tuesday, April 9, 2019 at 3:00 p.m.

L. ADJOURNMENT

The meeting was adjourned at 4:45 P.M.

Florida-Alabama



Transportation Planning Organization

Jeff Bergosh
Chairman

Sam Parker
Vice Chairman

P.O. Box 11399 • 32524-1399 Pensacola, FL • Street Address: 4081 E. Olive Road-Suite A • 32514
P: 850.332.7976 • 1.800.226.8914 • F: 850.637.1923 • www.wfrpc.org

MEMORANDUM

DATE: March 7, 2019

TO: Mr. Bryant Paulk, AICP, FDOT Urban Liaison
Ms. Christy Johnson, AICP, FDOT Urban Liaison
Mr. Vincent Beebe, P.E., ALDOT

COPIES TO: TPO, TCC, and CAC Members

FROM: Tiffany Bates, Transportation Program Coordinator

RE: TPO Actions Report – February 2019

The following items were discussed and acted upon by the Florida-Alabama Transportation Planning Organization (TPO) at the February 13, 2019 meeting. The TPO requests the Florida Department of Transportation (FDOT) and the Alabama Department of Transportation (ALDOT) to share this report with the appropriate department directors and to take action if requested by the TPO. Copies are sent to local government representatives for coordination with local plans.

LONG RANGE TRANSPORTATION PLAN:

The TPO approved Resolution FL-AL 19-02 approving the scope of services for the Florida-Alabama TPO 2045 Long Range Transportation Plan update. This action was recommended to begin the Long Range Plan update as soon as possible in order meet the November 3, 2020 adoption date.

SAFETY PERFORMANCE MEASURES

The TPO approved Resolution FL-AL 19-01 to adopt targets for safety performance measures, accepting FDOT's "Vision Zero" targets and ALDOT's "Toward Zero Death Initiative." This action was recommended to comply with the February 27, 2019 deadline to remain in compliance with the federal and state regulations for transportation planning.

CORRIDOR MANAGEMENT

The TPO approved Resolution FL-AL 19-05 approving TPO staff to coordinate with the City of Pensacola and Escambia County staff to finalize a Scope of Services and enter into a contract with the TPO's general planning consultant for the West Cervantes Street Corridor Traffic Feasibility Study. This action was requested so that the project can move forward.

TRANSPORTATION ALTERNATIVES SET-ASIDE PROGRAM

The TPO approved Resolution FL-AL 19-03 to adopt the Transportation Alternatives Set-Aside ranked projects, sending the top two ranked projects to FDOT. This action was recommended because all requirements of the competitive process were met and to comply with the February 28, 2019 deadline to submit applications to FDOT for consideration. The FL-ALTPO top two ranked projects are listed below:

1. City of Pensacola CRA: Multi-Modal Connectivity to Legion Field & Global Learning Academy
2. City of Pensacola CRA: Multi-Modal Connectivity to Downtown Pensacola via W. Main Street

TRANSIT

The TPO approved Resolution FL-AL 19-04 authorizing the TPO’s general planning consultant, HDR to develop a Bus Stop Assessment Plan. This action was recommended to comply with ADA Bus Stop accessibility requirements.

TPO ADMINISTRATION

The TPO approved authorizing the chairman to sign an Infrastructure for Rebuilding America (INFRA) grant application support letter for I-10 congestion relief for the Mobile River Bridge and Bayway project.



Florida Department of Transportation

RON DESANTIS
GOVERNOR

1074 Highway 90
Chipley, FL 32428

ERIK R. FENNIMAN
INTERIM SECRETARY

January 22, 2019

Mr. Austin Mount, Executive Director
Florida-Alabama Transportation Planning Organization
c/o West Florida Regional Planning Council
Post Office Box 11399
Pensacola, Florida 32524-1399

**Re: Rescheduled or Deleted Project(s) from the Adopted Work Program for
Fiscal Years 2020-2023**

Dear Mr. Mount:

According to Florida Statute 339.135, the Department of Transportation must provide written justification to the planning organization of any project that is a part of the MPO's Transportation Improvement Program (TIP) and in the last four years of the previously adopted Work Program (Fiscal Years 2020-2023) that has been proposed to be rescheduled or deleted.

Escambia County:

- **436088-2 SR 10 (US 90A) 9 Mile Road from CR 99 Beulah Road to SR 95 (US 29)**

Landscaping

Construction deferred from Fiscal Year 2020 to Fiscal Year 2021 due to the anticipated completion of construction for 218605-6 and 208605-7

Santa Rosa County:

- **407310-6 and 407310-7 SR 87 Yellow River Bridge No. 580094**
Construction deleted from Fiscal Year 2020 and advanced to Fiscal Year 2019 (Current Year)
- **431883-6 SR 30 (US 98) Corridor Management Improvement Projects**
Construction deleted from Fiscal Year 2021 and deferred to Fiscal Year 2024
- **437091-1 CR 197A Jay/Spring Street from School Street to Mildred Street**
Construction deleted from Fiscal Year 2020 and advanced to Fiscal Year 2019 (Current Year)
- **440626-1 CR 164 Greenwood Road from SR 89 to SR 4**
Construction deleted from Fiscal Year 2020 due to increased county population and changing Small County Outreach Program (SCOP) Eligibility

Please provide any written requests for changes to my attention at 1074 Highway 90, Chipley, Florida 32428 within 14 days. Should you have any questions, please contact Regina Battles, P.E., District Program Management Administrator, toll free at 1-888-638-0250, extension 1270 or via e-mail at regina.battles@dot.state.fl.us.

Sincerely,

Phillip Gainer, P.E.
District Secretary



Transportation Planning Organization

Jeff Bergosh
Chairman

Sam Parker
Vice Chairman

P.O. Box 11399 • 32524-1399 Pensacola, FL • Street Address: 4081 E. Olive Road-Suite A • 32514
P: 850.332.7976 • 1.800.226.8914 • F: 850.637.1923 • www.wfrpc.org

February 11, 2019

Michael Hora, Planning Section Supervisor
Local Transportation Bureau
Alabama Department of Transportation
1409 Coliseum Boulevard Room D-101
Montgomery, AL 36110

RE: Administrative Amendment to the FY 2019-2023 Transportation Improvement Program (TIP)

Dear Mr. Hora:

The FY 19-23 TIP has been modified to reflect the change in funding amounts, funding sources, and/or fiscal years for the following projects based upon a request from the Alabama Department of Transportation.

- 1) Project 100040566 SR 180 (Canal Road) Right-of-Way from SR 59 to Foley Beach Expressway. Change in funding sources (BPF to STPAA and BPS to ST), funding amounts (\$3,291,616 to \$3,357,777 and \$822,904 to \$839,444), and Fiscal Years (FY 2019/20 to FY 20/21).
- 2) Project 100040567 SR 180 (Canal Road) Utilities from SR 59 to Foley Beach Expressway. Change in funding sources (BPF to STPAA and BPS to ST), funding amounts (\$1,084,847 to \$1,095,695 and \$271,211 to \$273,923), and Fiscal Years (FY 2019/20 to FY 21/22).
- 3) Project 100060027 SR 42 (US 98) Design from Barclay Avenue to Alabama State Line. Moved from FY 18/19 to FY 19/20.
- 4) Project 100060029 SR 42 (US 98) Construction from Barclay Avenue to Alabama State Line. Moved from FY 18/19 to FY 19/20.

If you have any questions, please contact Mr. Gary Kramer at 1-800-226-8914, ext 219, or gary.kramer@wfrpc.org

With Sincere Appreciation,

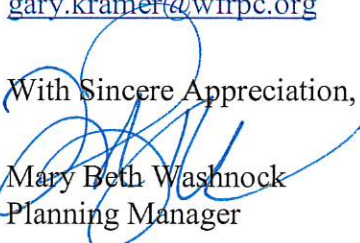

Mary Beth Washnock
Planning Manager

Attachments:

1. Modified FY 2019-2023 TIP Pages

Copies to:

Bryan Fair, ALDOT Montgomery
Vince Beebe, ALDOT Mobile

100060027

US 98 / SR 42

Non-SIS

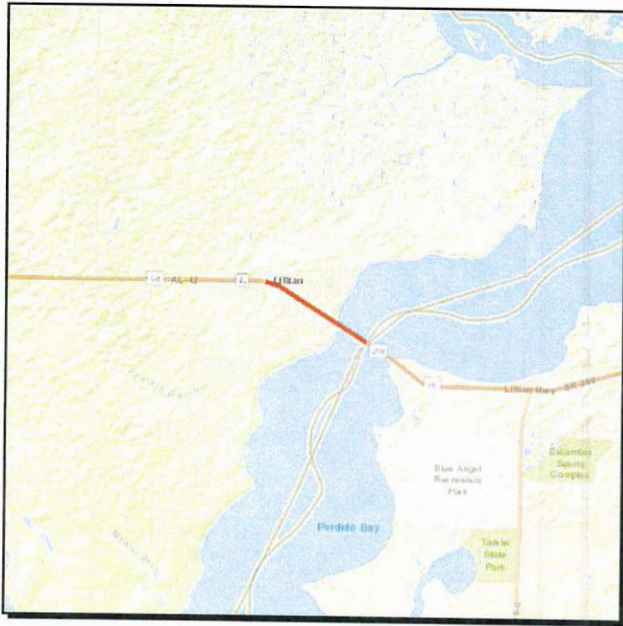

Work Summary: PAVE SHOULDERS

From: Barclay Ave

To: Alabama State Line

Lead Agency: ALDOT

Length: 1.35 MI

LRTP #: #5 in Amend. Report p. D-11

Phase	Fund Source	2018/19	2019/20	2020/21	2021/22	2022/23	Total
PE	STPLL	0	20,000	0	0	0	20,000
PE	LF	0	5,000	0	0	0	5,000
Total		0	25,000	0	0	0	25,000

Prior Cost < 2018/19: 0
 Future Cost > 2022/23: 0
 Total Project Cost: 25,000

Project Description: TPO Committed Alabama Bicycle & Pedestrian Project Priority.
 Pave shoulders on US 98/SR 42 from Barclay Ave. to the Alabama State Line.

100060029

US 98 / SR 42

Non-SIS



Work Summary: PAVE SHOULDERS

From: Barclay Ave

To: Alabama State Line

Lead Agency: ALDOT

Length: 1.35 MI

LRTP #: #5 in Amend. Report p. D-12

Phase	Fund Source	2018/19	2019/20	2020/21	2021/22	2022/23	Total
CST	STPLL	0	265,181	0	0	0	265,181
CST	LF	0	66,295	0	0	0	66,295
Total		0	331,476	0	0	0	331,476

Prior Cost < 2018/19: 0

Future Cost > 2022/23: 0

Total Project Cost: 331,476

Project Description: TPO Committed Alabama Bicycle & Pedestrian Project Priority.
Pave shoulders on US 98 / SR 42 from Barclay Ave. to the Alabama State Line.

100040566

SR 180 (CANAL ROAD)

Non-SIS

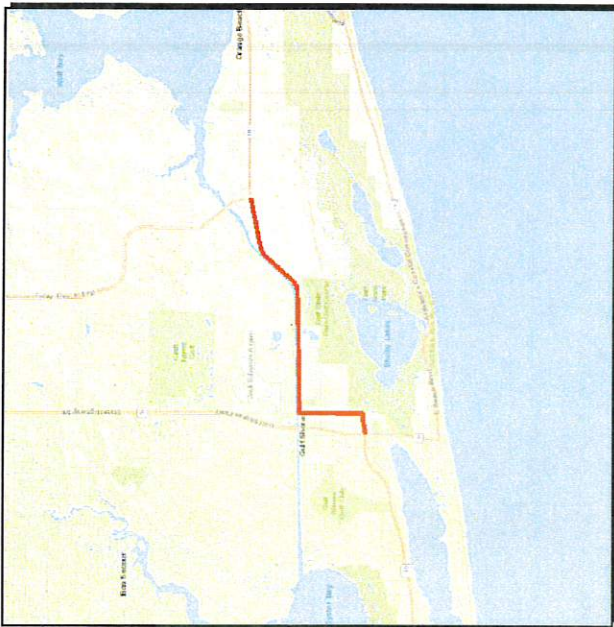

Work Summary: RIGHT OF WAY - FUTURE CAPACITY

From: SR 59

To: FOLEY BEACH EXPRESS

Lead Agency: ALDOT

Length: 4.74 MI

LRTP #: #1 in Amend. Report p. D-13

Phase	Fund Source	2018/19	2019/20	2020/21	2021/22	2022/23	Total
ROW	STPAA	0	0	3,357,777	0	0	3,357,777
ROW	ST	0	0	839,444	0	0	839,444
Total		0	0	4,197,221	0	0	4,197,221

Prior Cost < 2018/19: 0

Future Cost > 2022/23: 0

Total Project Cost: 4,197,221

Project Description:

Please note the segment from SR 59 to Gulf State Park is NOT within the TPO planning area. This segment is included for the logical termini of the project. Right-of-Way acquisition for 5-laning of SR 180 (Canal Road) from SR 59 to Foley Beach Express.

100040567

SR 180 (CANAL ROAD)

Non-SIS

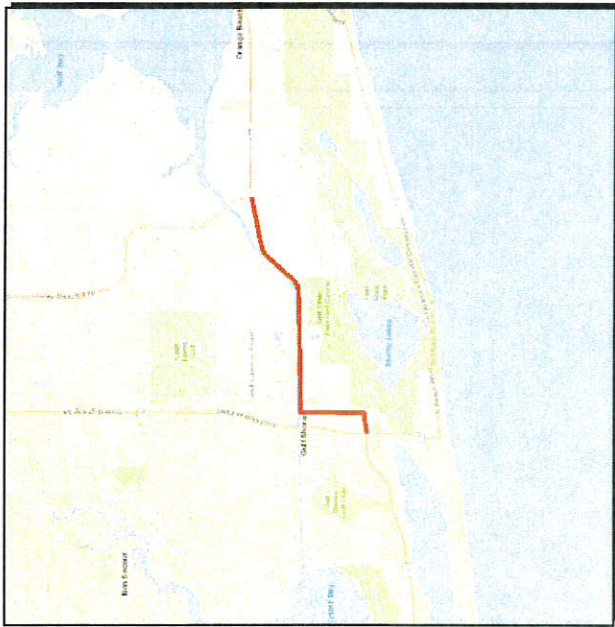

Work Summary: RELOCATE UTILITY SYSTEMS

From: SR 59

To: FOLEY BEACH EXPRESS

Lead Agency: ALDOT **Length:** 4.74 MI

L RTP #: #1 in Amend. Report p. D-13

Phase	Fund Source	2018/19	2019/20	2020/21	2021/22	2022/23	Total
UT	ST	0	0	0	273,923	0	273,923
UT	STPAA	0	0	0	1,095,695	0	1,095,695
Total		0	0	0	1,369,618	0	1,369,618

Prior Cost < 2018/19: 0
Future Cost > 2022/23: 0
Total Project Cost: 1,369,618

Project Description: Please note the segment from SR 59 to Gulf State Park is NOT within the TPO planning area. This segment is included for the logical termini of the project. Relocation of utilities for the 5-laning of SR 180 (Canal Road) from SR 59 to Foley Beach Express.

AIR QUALITY UPDATE

SUBJECT: Air Quality Status Report: Florida-Alabama, Okaloosa-Walton, and Bay TPOs

REPORTING PERIOD: January-March 2018

ORIGIN OF SUBJECT: Unified Planning Work Program, Task C-3

LOCAL GOVERNMENT ACTION NEEDED: Monitor

BACKGROUND:

Based on extensive scientific evidence about ozone effects on public health and welfare, EPA set the National Ambient Air Quality Standard (NAAQS) for ground level ozone at 70 parts per billion (ppb). Northwest Florida is in attainment; however, if Florida has any areas designated as nonattainment, Florida DEP will develop a State Implementation Plan (SIP) providing for the measures necessary to bring the areas into compliance with the revised NAAQS. Transportation conformity would be required in these nonattainment areas meaning a periodic demonstration must be made that transportation activities will not cause new air quality violations, worsen existing violations, or delay timely attainment of the NAAQS.

The purpose of this report is to provide the TPOs with current information on ozone levels in the Metropolitan Planning Area (MPA). The Florida Department of Environmental Protection (FDEP) publishes annual Air Quality Status Attainment Reports. Attainment Reports are a three-year average of the 4th highest annual 8-hour ozone readings. The ozone season is from April 1st through October 31st.

RECOMMENDED ACTION: This item is for information only.

REPORT:

The federal standard for ozone has been established at a level equivalent to 70 parts per billion averaged over any 8-hour period. An area will be considered in violation (not meeting the standard) if the average of the annual fourth highest maximum daily 8-hour average ozone concentration at any ozone monitor for a three-year period exceeds 70 parts per billion. The table below shows the highest 8-hour averages of ozone in each TPO region for the reporting period.

Air Quality Monitoring Attainment Status Update for January-March 2019					
<small>fdep.dep.state.fl.us/air/flaqs/selectreport.asp (April 3, 2018)</small>					
TPO	Air Quality Monitoring Station	Highest 8-Hour Ozone Reading in Parts Per Billion (Date of Reading)		2018 3-year Attainment Average	2019 year-to-date 3-year Running Average
Florida-Alabama	Ellyson Industrial Park	60	(Mar 20, 24)	65	62
	Pensacola NAS	62	(Mar 24)	63	62
	Woodlawn Beach Middle School	63	(Mar 24)	61	60
Okaloosa-Walton	Fort Walton Beach	65	(Mar 24)	61	59
Bay County	St. Andrews State Park	65	(Mar 23)	60	58
Regional	Bonifay, Holmes County	65	(Mar 24)	58	56

ADDITIONAL INFORMATION:

Ground-level Ozone (Smog)¹

Ozone also occurs naturally near the earth's surface. However, man-made emissions of VOCs and NO_x can cause additional ozone, the primary component of urban smog, to be formed. This additional ozone, which can more than triple the amount of natural ground-level ozone, can cause health and environmental damage. Ozone builds up near the ground through a series of complex chemical reactions involving VOCs and NO_x in the presence of sunlight. VOCs are produced by natural sources, such as trees; fuel combustion in engines and industrial operations; some types of chemical manufacturing operations; evaporation of solvents in consumer and commercial products; and evaporation of volatile fuels such as gasoline. NO_x are emitted from motor vehicles; off-road engines such as aircraft, locomotives and construction equipment; fossil-fuel burning power plants and other industrial facilities; and other sources of combustion.

Ozone concentrations can reach unhealthy levels when the weather is hot and sunny with relatively light winds. Even at relatively low levels, ozone may cause inflammation and irritation of the respiratory tract, particularly during physical activity. The resulting symptoms can include breathing difficulty, coughing and throat irritation. Breathing ozone can affect lung function and worsen asthma attacks. Ozone also can increase the susceptibility of the lungs to infections, allergens and other air pollutants. Groups that are sensitive to ozone include children and adults who are active outdoors, and people with respiratory disease such as asthma. Sensitive people who experience effects at lower ozone concentrations are likely to experience more serious effects at higher concentrations.

The U.S. Environmental Protection Agency has established a health-based air quality standard for ozone. The Florida Department of Environmental Protection, in cooperation with several county air pollution control agencies, monitors ozone air quality in Florida's major urban areas.

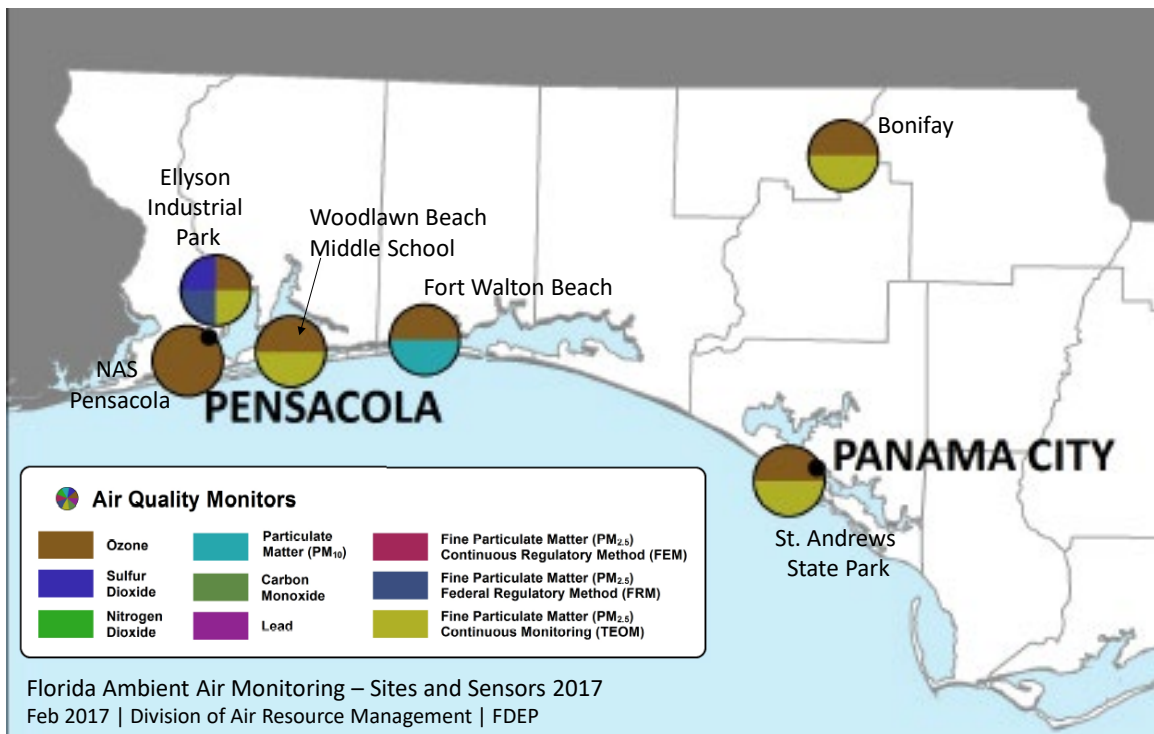

¹ floridadep.gov/air/air/content/air-quality-101 (accessed March 2018)

2019 Schedule

Florida-Alabama Transportation Planning Organization

Below are the 2019 scheduled meeting locations, dates, and times for the Florida-Alabama Transportation Planning Organization Board, Technical Coordinating Committee, and Citizens' Advisory Committee. (Meeting schedule and location are subject to change. For updates and agendas, please visit www.wfrpc.org or email tiffany.bates@wfrpc.org.)

February

TCC: Feb. 11, 8:30 a.m.
Pensacola City Hall
222 W. Main Street

CAC: Feb. 12, 3 p.m.
Pensacola City Hall
222 W. Main Street

TPO Board: Feb. 13, 9 a.m.
W. Florida Regional Library*
239 N. Spring Street, Pensacola

April

TCC: Apr. 8, 8:30 a.m.
Pensacola City Hall
222 W. Main Street

CAC: Apr. 9, 3 p.m.
Pensacola City Hall
222 W. Main Street

TPO Board: Apr. 10, 9 a.m.
Tiger Point Community Center
1370 Tiger Point Lane, Gulf Breeze

June

TCC: June 10, 8:30 a.m.
Pensacola City Hall
222 W. Main Street

CAC: June 11, 3 p.m.
Pensacola City Hall
222 W. Main Street

TPO Board: June 12, 9 a.m.
W. Florida Regional Library*
239 N. Spring Street, Pensacola

July

TCC: July 8, 8:30 a.m.
Pensacola City Hall
222 W. Main Street

CAC: July 9, 3 p.m.
Pensacola City Hall
222 W. Main Street

TPO Board: July 10, 9 a.m.
Tiger Point Community Center
1370 Tiger Point Lane, Gulf Breeze

October

TCC: Oct. 7, 8:30 a.m.
Pensacola City Hall
222 W. Main Street

CAC: Oct. 8, 3 p.m.
Pensacola City Hall
222 W. Main Street

TPO Board: Oct. 9, 9 a.m.
W. Florida Regional Library*
239 N. Spring Street, Pensacola

December

TCC: Dec. 9, 8:30 a.m.
Pensacola City Hall
222 W. Main Street

CAC: Dec. 10, 3 p.m.
Pensacola City Hall
222 W. Main Street

TPO Board: Dec. 11, 9 a.m.
Tiger Point Community Center
1370 Tiger Point Lane, Gulf Breeze



* This event is not sponsored or endorsed by the West Florida Public Libraries or Escambia County.

The FL-AL TPO is staffed by the West Florida Regional Planning Council, a regional entity providing professional planning, coordinating, and advisory services to local governments, state and federal agencies, and the public to preserve and enhance quality of life in northwest Florida. *Public participation is solicited without regard to race, color, national origin, sex, age, religion, disability, or family status. Reasonable accommodation will be made for access in accordance with the Americans with Disabilities Act. Contact Brittany Ellers, 850-332-7976, ext. 220 or brittany.ellers@wfrpc.org, or TTY 711. Por favor a la Sr. Dan Deanda, de los requisitos de acceso o el idioma en el 850-332-7976 ext. 227 o TTY 711 al menos 48 horas de antelacion.*